



**HIGH ACCURACY**

m e a s u r e m e n t i n s t r u m e n t s

## PRODUCT DATASHEET

[www.high-accuracy.com](http://www.high-accuracy.com)

# Rosemount™ 2090F Hygienic Pressure Transmitter



- Conforms to 3-A® Sanitary Standards
- Features CIP/SIP service for process temperatures up to 284 °F (140 °C)
- Absolute or gage pressure ranges up to 300 psi
- Mounts with either 1½ or 2-in. Tri Clamp connection
- Performance of 0.10 percent with high accuracy option

# Accurate, stable, and reliable pressure measurement for the hygienic industries

## Conforms to 3-A Sanitary Standards

The hygienic design of the Rosemount 2090F conforms to 3-A Sanitary Standards, and is USDA accepted. The materials of construction are Generally Recognized As Safe (GRAS) by the FDA, making it the ideal choice for any hygienic application.

## Features CIP/SIP service with an upper temperature limit of 284 °F (140 °C)

The Rosemount 2090F provides accurate, stable, and reliable pressure measurement, which makes it an ideal choice for pharmaceutical and food and beverage applications, including CIP/SIP service for process temperatures up to 284 °F (140 °C).

## Absolute or gauge pressure ranges up to 300 psi and 20:1 turndown

Higher turndown allows for lower inventories by allowing you to measure pressures from 1.5 to 300 psi with only three transmitter ranges.

## Mounts with either 1½ or 2-in. Tri Clamp connection

The Rosemount 2090F is available with both 1½ and 2-in. Tri Clamp process connections, designed for sanitary applications to easily connect to standard sanitary fittings without requiring special mounting hardware.

## 0.10 percent reference accuracy performance with P8 high accuracy option

The single-filled sensor system of the Rosemount 2090F leads to outstanding accuracy due to full sensor compensation.

### Contents

Ordering information .....	3	Product Certifications .....	9
Specifications .....	6	Dimensional drawings .....	13

## Ordering information

Specification and selection of product materials, options, or components must be made by the purchaser of the equipment. See [page 7](#) for more information on Material Selection.

**Table 1. Rosemount 2090F Pressure Transmitter Ordering Information**

The starred offerings (★) represent the most common options and should be selected for best delivery. The non-starred offerings are subject to additional delivery lead time.

Model	Product description			
2090F	Hygienic Pressure Transmitter			
<b>Transmitter type</b>				
A	Absolute			★
G	Gage			★
<b>Pressure ranges (range/minimum span)</b>				
	<b>Rosemount 2090FG</b>		<b>Rosemount 2090FA</b>	
1	-14.7 to 30 psi/1.5 psi (-1,01 to 2,1 bar/103 mbar)		0 to 30 psia/1.5 psi (0 to 2,1 bar/103 mbar)	★
2	-14.7 to 150 psi/7.5 psi (-1,01 to 10,3 bar/517 mbar)		0 to 150 psia/7.5 psi (0 to 10,3 bar/517 mbar)	★
3	-14.7 to 300 psi/40 psi (-1.01 to 20,7 bar/2,8 bar)		0 to 300 psia/40 psi (0 to 20,7 bar/2,8 bar)	★
<b>Output</b>				
S	4–20 mA dc/digital HART® Protocol			★
<b>Material of construction</b>				
	<b>Process connection</b>	<b>Isolating diaphragm</b>	<b>Oil fill</b>	
2D	316L SST (Stainless Steel)	316L SST	Neobee®	★
<b>Process connection</b>				
E	1½-in. Tri Clamp connection			★
F	2-in. Tri Clamp connection			★
<b>Conduit entry</b>				
1	½–14 NPT			★
2	M20 × 1.5 female			★

### Options(include with selected model number)

<b>Extended product warranty</b>				
WR3	3-year limited warranty			★
WR5	5-year limited warranty			★
<b>Digital display</b>				
M5	LCD display, configured for percent of range			★
<b>Mounting brackets</b>				
B4	SST mounting bracket with SST bolts			★

**Table 1. Rosemount 2090F Pressure Transmitter Ordering Information**

The starred offerings (★) represent the most common options and should be selected for best delivery. The non-starred offerings are subject to additional delivery lead time.

<b>Product certifications</b>		
E5	USA Explosionproof (XP) and Dust-Ignitionproof (DIP)	★
ED	ATEX Flameproof	★
EM	Technical Regulations Customs Union (EAC) Flameproof	★
I5	USA Intrinsic Safety (IS) and Nonincendive (NI)	★
K5	USA Explosionproof (XP), Dust-Ignitionproof (DIP), Intrinsic Safety (IS), and Nonincendive (NI)	★
I1	ATEX Intrinsic Safety	★
N1	ATEX Type n	★
C6	Canada Explosionproof, Intrinsic Safety, Division 2, and Dust-Ignitionproof	★
KB	USA Explosionproof, Dust-Ignitionproof, Intrinsic Safety, Nonincendive and Canada Explosionproof, Intrinsic Safety, Division 2, and Dust-Ignitionproof	★
KM	Technical Regulation Customs Union (EAC) Flameproof and Intrinsic Safety	★
KH	ATEX Flameproof, Intrinsic Safety, USA Explosionproof, Dust-Ignitionproof, Intrinsic Safety, and Nonincendive	★
ND	ATEX Dust	★
NK	IECEx Dust	★
K7	IECEx Flameproof, Dust, Intrinsic Safety, Type n	★
K1	ATEX Flameproof, Dust, Intrinsic Safety, Type n	★
K6	Canada Explosion-Proof, Intrinsic Safety, Division 2, Dust-ignitionproof, and ATEX Flameproof, Intrinsic Safety	★
I3	China Intrinsic Safety	★
IM	Technical Regulation Customs Union (EAC) Intrinsic Safety	★
E3	China Flameproof	★
<b>Terminal blocks</b>		
T1	Transient protection	★
<b>Special certificate</b>		
Q4	Calibration certificate	★
<b>Quality calibration certificate traceability certification</b>		
Q8	Material traceability certification per EN 10204 3.1	★
<b>Alarm limit</b>		
C4	NAMUR alarm and saturation levels, high alarm	★
CN	NAMUR alarm and saturation levels, low alarm	★
<b>Special procedures</b>		
P2	Cleaning for special service	
<b>Calibration accuracy</b>		
P8	0.1 percent accuracy to 10:1 turndown	★
<b>Typical model number: 2090F G 2 S 2D E 1</b>		

## Standard configuration

Unless otherwise specified, transmitter is shipped as follows:

- Engineering units: psi
- 4 mA: 0 psi
- 20 mA: Upper range limit
- Alarm output: high
- LCD display: 0 to 100 percent

## Custom configuration

### Calibration

Transmitters are factory calibrated to customer's specified range.

If calibration is not specified, transmitters are calibrated at maximum range. Calibration is at ambient temperature and pressure.

### Tagging

The transmitter will be tagged, at no charge, in accordance with customer requirements. All tags are stainless steel. The standard tag is wired to the transmitter. Tag character height is  $\frac{1}{8}$ -in. (0.318 cm). A permanently attached tag is available upon request.

### Accessories

Item description	Part number
Calibration adapter, 1 $\frac{1}{2}$ -in. Use to connect a calibration device to a transmitter.	02088-0197 -0011
Calibration adapter, 2-in. Use to connect a calibration device to a transmitter.	02088-0197 -0012

# Specifications

## Functional specifications

### Service

Liquid, gas, vapor, and high-viscosity applications

### Ranges

Range	Minimum span	Upper (URL)	Lower (LRL)	Lower <sup>(1)</sup> (LRL)(gage)
1	1.5 psi (103 mbar)	30 psi (2,1 bar)	0 psia (0 bar)	-14.7 psig (-1,01 bar)
2	7.5 psi (517 mbar)	150 psi (10,3 bar)		
3	40 psi (2,76 bar)	300 psi (20,7 bar)		

1. Assumes atmospheric pressure of 14.7 psig.

### Output

4–20 mA Selectable HART Protocol

### Range down

20:1

### Load limitations

Maximum loop resistance is determined by the power supply voltage, as described by the following equation:

Maximum loop resistance = 43.5 (power supply voltage – 10.5)

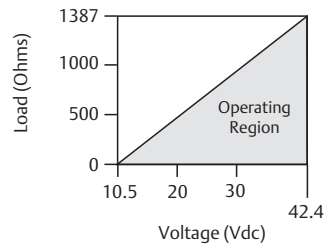

The Field Communicator requires a minimum loop resistance of 250 Ω for communication.

### Power supply

External power supply required. Transmitter operates on 10.5–42.4 Vdc with no load. Reverse polarity protection is standard.

### Overpressure limits

Range	Overpressure limit <sup>(1)</sup>
1	120 psi (8,3 bar)
2	300 psi (20,7 bar)
3	600 psi (41,4 bar)

1. Overpressure limit is dependent on the clamp/pressure adapter or sensor rating (whichever is lower).

### Temperature limits

#### Process

–4 to 284 °F (–20 to 140 °C)

#### Ambient

–4 to 185 °F (–20 to 85 °C)

#### Storage

–22 to 185 °F (–30 to 85 °C)

Process temperatures above 185 °F (85 °C) require lowering the ambient limits by a 1.5:1 ratio:

$$\text{Max. ambient temperature in } ^\circ\text{F} = 85 - \frac{(\text{Process Temp} - 185)}{1.5}$$

$$\text{Max. ambient temperature in } ^\circ\text{C} = 85 - \frac{(\text{Process Temp} - 85)}{1.5}$$

### Humidity limits

0 to 100 percent relative humidity

### Volumetric displacement

Less than 0.0005 in<sup>3</sup> (0,008 cm<sup>3</sup>)

### Turn-on time

Performance within specifications less than 2.0 seconds after power is applied to the transmitter

### Failure alarm

If self-diagnostics detect a sensor or microprocessor failure, the analog signal is driven either high or low to alert the user. High or low failure mode is user-selectable by a jumper on the transmitter. The values to which the transmitter drives its output in failure mode depend on whether it is factory-configured to standard or NAMUR-compliant operation. The values for each are as follows:

#### Standard operation

Linear output: 3.9 ≤ I ≤ 20.8

Fail high: I ≥ 21.75 mA

Low: I ≤ 3.75 mA

**NAMUR-compliant operation**

Linear output:  $3.8 \leq I \leq 20.5$   
 Fail high:  $I \geq 22.5$  mA  
 Low:  $I \leq 3.6$  mA

**Transmitter security**

Activating the transmitter security function prevents changes to the transmitter configuration, including local zero and span adjustments. Security is activated by an internal jumper.

**Performance specifications**

Zero-based spans, reference conditions, and 316 SST isolating diaphragm

**Reference accuracy**

$\pm 0.20$  percent of calibrated span. Includes combined effects of linearity, hysteresis, and repeatability.

High accuracy (P8) option:

$\pm 0.10$  percent of calibrated span to 10:1 turndown

**Ambient temperature effect per 50 °F (28 °C)**

$\pm (0.15\% \text{ URL} + 0.15\% \text{ span})$  from 1:1 to 20:1

**Stability**

$\pm 0.10$  percent of URL for one year, reference stability

**Time response****Total response time<sup>(1)</sup>**

145 ms

**Update rate**

22 times per second

1. Nominal total response time at 75 °F (24 °C) reference conditions.

**Vibration effect**

Less than  $\pm 0.1$  percent of upper range limit when subjected to vibration of peak to peak constant displacement of 4 mm (5 to 15 Hz) and constant acceleration of 2 g (15 to 150 Hz) and 1 g (150 to 2000 Hz)

**Power supply effect**

Less than  $\pm 0.005$  percent of calibrated span per volt

**Electromagnetic compatibility (EMC)**

Meets all industrial environment requirements of EN61326 and NAMUR NE-21<sup>(1)</sup>. Maximum deviation < 1 percent span during EMC disturbance<sup>(2)</sup>.

1. NAMUR NE-21 does not apply to low-power (Transmitter output option code N).

2. During surge event device may exceed maximum EMC deviation limit or reset; however, device will self-recover and return to normal operation within specified start-up time.

**Mounting position effect**

Zero shift of up to 5.0 inH<sub>2</sub>O (12,4 mbar), which can be calibrated out. No span effect.

**Physical specifications****Material selection**

Emerson provides a variety of Rosemount product with various product options and configurations including materials of construction that can be expected to perform well in a wide range of applications. The Rosemount product information presented is intended as a guide for the purchaser to make an appropriate selection for the application. It is the purchaser's sole responsibility to make a careful analysis of all process parameters (such as all chemical components, temperature, pressure, flow rate, abrasives, contaminants, etc.), when specifying product, materials, options and components for the particular application. Emerson is not in a position to evaluate or guarantee the compatibility of the process fluid or other process parameters with the product, options, configuration or materials of construction selected.

**Electrical connection**

1/2-14 NPT or M20 × 1.5 conduit entry

**Process wetted parts****Isolating diaphragm**

316L SST

**Process connector**

316L SST

**Transmissible Spongiform Encephalopathy (TSE) Declaration**

Emerson certifies no process wetted components used in this product contain substances of animal origin. Materials used in the production or processing of wetted components for this products meet the requirements stated in EMA/410/01 Rev. 3 and ISO 2242-1:2015. Wetted components in this product are considered free of TSE.

**Non-wetted parts****Electronics housing**

Low-copper aluminum

Enclosures meet NEMA<sup>®</sup> Type 4X, IP66, and IP68 when properly installed

**Paint**

Polyurethane

**Cover O-rings**

Buna-N

**Paint**

Polyurethane

**Fill fluid**

Neobee M-20

**Weight**

Approximately 2.74 lb (1,24 kg)

# Product Certifications

Rev 2.0

## European Directive Information

A copy of the EU Declaration of Conformity can be found at the end of the Quick Start Guide. The most recent revision of the EU Declaration of Conformity can be found at [Emerson.com/Rosemount](http://Emerson.com/Rosemount).

## Ordinary Location Certification

As standard, the transmitter has been examined and tested to determine that the design meets the basic electrical, mechanical, and fire protection requirements by a nationally recognized test laboratory (NRTL) as accredited by the Federal Occupational Safety and Health Administration (OSHA).

## North America

- E5** USA Explosionproof (XP) and Dust-Ignitionproof (DIP)  
Certificate: 1015441  
Standards: FM Class 3600 – 2011, FM Class 3615 – 2006, FM class 3616 – 2011, FM Class 3810 – 2005, ANSI/NEMA 250 – 1991  
Markings: XP CL I, DIV 1, GP B, C, D; DIP CL II, DIV 1, GP E, F, G; CL III, DIV 1; T5(–50 °C ≤ T<sub>a</sub> ≤ +85 °C); Conduit Seal Not Required; Type 4X
- I5** USA Intrinsically Safe (IS) and Nonincendive (NI)  
Certificate: 1015441  
Standards: FM Class 3600 – 1998, FM Class 3610 – 2010, FM Class 3611 – 2004, FM Class 3810 – 1989  
Markings: IS CL I, DIV 1, GP A, B, C, D; CL II, DIV 1, GP E, F, G; Class III T4(–50 °C ≤ T<sub>a</sub> ≤ +70 °C); when connected per Rosemount drawing 02088-1024; NI CL 1, DIV 2, GP A, B, C, D; Type 4x
- C6** Canada Explosionproof, Intrinsically Safe, and Division 2, and Dust-Ignitionproof  
Certificate: 1015441  
Standards: CAN/CSA C22.2 No. 0-M91 (R2001), CSA Std C22.2 No. 25-1966, CSA Std C22.2 No. 30-M1986, CAN/CSA-C22.2 No. 94-M91, CSA Std C22.2 No. 142-M1987, CAN/CSA-C22.2 No. 157-92, CSA Std C22.2 No. 213-M1987, ANSI-ISA-12.27.01-2003  
Markings: Explosionproof for Class I, Division 1, Groups B, C and D; Class II, Groups E, F, and G; Class III; Intrinsically Safe Class I, Division 1 when connected in accordance with Rosemount drawing 02088-1024, Temperature Code T3C; Ex ia; Class I Division 2 Groups A, B, C and D; Type 4X; Factory Sealed

## Europe

- ED** ATEX Flameproof  
Certificate: KEMA97ATEX2378X  
Standards: EN60079-0:2012 + A11:2013, EN60079-1:2014, EN60079-26:2015  
Markings: Ⓔ II 1/2 G Ex db IIC T6... T4 Ga/Gb, T6(–60 °C ≤ T<sub>a</sub> ≤ +70 °C), T4/T5(–60 °C ≤ T<sub>a</sub> ≤ +80 °C)

### Special Condition for Safe Use (X):

1. This device contains a thin wall diaphragm. Installation, maintenance and use shall take into account the environmental conditions to which the diaphragm will be subjected. The manufacturer's instructions for installation and maintenance shall be followed in detail to assure safety during its expected lifetime.
  2. Flameproof joints are not intended for repair.
  3. Non-standard paint options may cause risk from electrostatic discharge. Avoid installations that could cause electrostatic build-up on painted surfaces, and only clean the painted surfaces with a damp cloth. If paint is ordered through a special option code, contact the manufacturer for more information.
- I1** ATEX Intrinsic Safety  
Certificate: BAS00ATEX1166X  
Standards: EN60079-0:2012+A11:2013, EN60079-11:2012  
Markings: Ⓔ II 1 G Ex ia IIC T4 Ga (–55 °C ≤ T<sub>a</sub> ≤ +70 °C)

**Table 2. Input Parameters**

Parameter	HART
Voltage U <sub>i</sub>	30 V
Current I <sub>i</sub>	200 mA
Power P <sub>i</sub>	0.9 W
Capacitance C <sub>i</sub>	0.012 μF

### Special Condition for Safe Use (X):

1. The apparatus is not capable of withstanding the 500 V insulation test required by EN60079-11. This must be taken into account when installing the apparatus.
  2. The enclosure may be made of aluminum alloy and given a protective polyurethane paint finish; however, care should be taken to protect it from impact or abrasion if located in a Zone 0 environment.
- N1** ATEX Type n  
Certificate: BAS00ATEX3167X  
Standards: EN60079-0:2012+A11:2013, EN60079-15:2010  
Markings: Ⓔ II 3 G Ex nA IIC T5 Gc (–55 °C ≤ T<sub>a</sub> ≤ +70 °C)

**Special Condition for Safe Use (X):**

1. When fitted with a transient suppression terminal block, the equipment is not capable of withstanding the 500 V isolation test that is required by EN60079-15. This must be taken into account when installing the apparatus.

**ND** ATEX Dust

Certificate: BAS01ATEX1427X  
 Standards: EN60079-0:2012+A11:2013, EN60079-31:2009  
 Markings:  II 1 D Ex t IIIC T 50 °C T<sub>500</sub> 60 °C Da

**Special Conditions for Safe Use (X):**

1. Cable entries must be used which maintain the ingress protection of the enclosure to at least IP66.
2. Unused cable entries must be filled with suitable blanking plugs which maintain the ingress protection of the enclosure to at least IP66.
3. Cable entries and blanking plugs must be suitable for the ambient range of the apparatus and capable of withstanding a 7 J impact test.

**International**

**K7** Combination

IECEX Flameproof  
 Certificate: IECEX KEM 06.0021X  
 Standards: IEC60079-0:2011, IEC60079-1:2014, IEC60079-26:2014  
 Markings: Ex db IIC T6...T4 Ga/Gb, T6(-60 °C ≤ T<sub>a</sub> ≤ +70 °C), T4/T5(-60 °C ≤ T<sub>a</sub> ≤ +80 °C);

**Special Conditions for Safe Use (X):**

1. The device contains a thin wall diaphragm less than 1 mm thickness that forms a boundary between EPL Ga (process connection) and EPL Gb (all other parts of the equipment). The model code and datasheet are to be consulted for details of the diaphragm material. Installation, maintenance and use shall take into account the environmental conditions to which the diaphragm shall be subjected. The manufacturer's instructions for installation and maintenance shall be followed in detail to assure safety during its expected lifetime.
2. Flameproof joints are not intended for repair.
3. Non-standard paint options may cause risk from electrostatic discharge. Avoid installations that could cause electrostatic build-up on painted surfaces, and only clean the painted surfaces with a damp cloth. If paint is ordered through a special option code, contact the manufacturer for more information.

IECEX Dust: see Approval Option NK  
 IECEX Intrinsic Safety  
 Certificate: IECEX BAS 12.0071X  
 Standards: IEC60079-0:2011, IEC60079-11:2011  
 Markings: Ex ia IIC T4 Ga (-55 °C ≤ T<sub>a</sub> ≤ +70 °C),

**Table 3. Input Parameters**

Parameter	HART
Voltage U <sub>i</sub>	30 V
Current I <sub>i</sub>	200 mA
Power P <sub>i</sub>	0.9 W
Capacitance C <sub>i</sub>	0.012 μF

**Special Conditions for Safe Use (X):**

1. When fitted with a transient suppression terminal block, the Rosemount 2090 is incapable of passing the 500 V isolation test. This must be taken into account during installation.
2. The enclosure may be made of aluminum alloy and given a protective polyurethane paint finish; however, care should be taken to protect it from impact or abrasion if located in a Zone 0 environment.

IECEX Type n  
 Certificate: IECEX BAS 12.0072X  
 Standards: IEC60079-0:2011, IEC60079-15:2010  
 Markings: Ex nA IIC T5 Gc (-40 °C ≤ T<sub>a</sub> ≤ +70 °C)

**Special Condition for Safe Use (X):**

1. When fitted with a transient suppression terminal block, the device is incapable of passing the 500 V isolation test. This must be taken into account during installation.

**NK** IECEX Dust

Certificate: IECEX BAS12.0073X  
 Standards: IEC60079-0:2011, IEC60079-31:2008  
 Markings: Ex t IIIC T 50 °C T<sub>500</sub> 60 °C Da

**Table 4. Input Parameters**

Parameter	HART
Voltage U <sub>i</sub>	36 Vdc
Current I <sub>i</sub>	24 mA

**Special Conditions for Safe Use (X):**

1. Cable entries must be used which mention the ingress protection of the enclosure to at least IP66.
2. Unused cable entries must be filled with suitable blanking plugs which maintain the ingress protection of the enclosure to at least IP66.
3. Cable entries and blanking plugs must be suitable for the ambient range of the apparatus and capable of withstanding a 7 J impact test.

## China

- E3** China Flameproof  
 Certificate: GYJ15.1506X  
 Standards: GB3836.1-2010, GB3836.2-2010  
 Markings: Ex d IIC T6/T4 Gb, T6(-20 °C ≤ T<sub>a</sub> ≤ +40 °C),  
 T4(-20 °C ≤ T<sub>a</sub> ≤ +80 °C)

### Special Conditions for Safe Use (X):

- The ambient temperature is as follows:

T <sub>a</sub>	Temperature class
-20 °C ≤ T <sub>a</sub> ≤ 80 °C	T4
-20 °C ≤ T <sub>a</sub> ≤ 40 °C	T6

- The earth connection facility in the enclosure should be connected reliably.
- During installation in hazardous location, cable glands, conduits, and blanking plugs, certified by state-appointed inspection bodies with Ex d IIC type of protection, should be used.
- During installation, use and maintenance in explosive gas atmospheres, observe the warning “Do not open when energized.”
- During installation, there should be no mixture harm to flameproof housing.
- End user is not permitted to change any components insides, but to settle the problem in conjunction with manufacturer to avoid damage to the product.
- Maintenance should be done in non-hazardous location.
- During installation, use and maintenance of this product, observe the following standards: GB3836.13-2013, GB3836.15-2000, GB3836.16-2006, GB50257-2014.

- I3** China Intrinsic Safety  
 Certificate: GYJ15.1508X  
 Standards: GB3836.1-2010, GB3836.4-2010,  
 GB3836.20-2010  
 Markings: Ex ia IIC T4 Ga

### Special Conditions for Safe Use (X):

- The enclosure may be made of aluminum alloy and given a protective polyurethane paint finish; however, care should be taken to protect it from impact or abrasion if located in a zone 0 environment.
- This apparatus is not capable of withstanding the 500 V r.m.s. insulation test required by Clause 6.3.12 of GB3836.4-2010.
- The ambient temperature is:

T <sub>a</sub>	Temperature class
-55 °C ≤ T <sub>a</sub> ≤ 70 °C	T4

- Intrinsically safe parameters:

Parameter	HART
Voltage U <sub>i</sub>	30 V
Current I <sub>i</sub>	200 mA
Power P <sub>i</sub>	0.9 W
Capacitance C <sub>i</sub>	0.012 μF
Inductance L <sub>i</sub>	0 mH

- The product should be used with Ex-certified linear associated apparatus to establish explosion protection system that can be used in explosive gas atmospheres. Wiring and terminals should comply with the instruction manual of the product and associated apparatus.
- The cables between this product and associated apparatus should be shielded cables (the cables must have insulated shields). The shield has to be grounded reliably in a non-hazardous area.
- End users are not permitted to change any internal components, but to settle the problem in conjunction with the manufacturer to avoid damage to the product.
- During installation, use and maintenance of this product, observe the following standards: GB3836.13-2013, GB3836.15-2000, GB3836.16-2006, G3836.18-2010, GB50257-2014.

## Technical Regulations Customs Union (EAC)

**EM** EAC Flameproof  
 Markings: Ga/Gb Ex db IIC T4...T6 X, T4/T5 (-60 °C ≤ T<sub>a</sub> ≤ +80 °C), T6 (-60 °C ≤ T<sub>a</sub> ≤ +70 °C)

**Special Condition for Safe Use (X):**

See certificate for special conditions.

**IM** EAC Intrinsically Safe  
 Markings: 0Ex ia IIC T4 Ga X (-55 °C ≤ T<sub>a</sub> ≤ +70 °C)

**Special Conditions for Safe Use (X):**

See certificate for special conditions.

## Combinations

- K1** Combination of ED, I1, ND, and N1
- K5** Combination of E5 and I5
- K6** Combination of C6, ED, and I1
- KB** Combination of K5 and C6
- KM** Combination of EM and IM
- KH** Combination of ED, I1, and K5

## Conduit plugs and adapters

IECEx Flameproof and Increased Safety  
 Certificate: IECEx FMG 13.0032X  
 Standards: IEC60079-0:2011, IEC60079-1:2007-04,  
 IEC60079-7:2006-07

Markings: Ex de IIC Gb

ATEX Flameproof and Increased Safety  
 Certificate: FM13ATEX0076X  
 Standards: EN60079-0:2012, EN60079-1:2007,  
 EN60079-7:2007

Markings:  II 2 G Ex de IIC Gb

**Table 5. Conduit Plug Thread Sizes**

Thread	Identification mark
M20 × 1.5	M20
1/2-14 NPT	1/2 NPT
G1/2A	G1/2

**Table 6. Thread Adapter Thread Sizes**

Male thread	Identification mark
M20 × 1.5 – 6H	M20
1/2-14 NPT	1/2-14 NPT
3/4-14 NPT	3/4-14 NPT
Female thread	Identification mark
M20 × 1.5 – 6H	M20
1/2-14 NPT	1/2-14 NPT
PG 13.5	PG 13.5

**Special Conditions for Safe Use (X):**

- When the thread adapter or blanking plug is used with an enclosure in type of protection increased safety “e” the entry thread shall be suitably sealed in order to maintain the ingress protection rating (IP) of the enclosure.
- The blanking plug shall not be used with an adapter.
- Blanking Plug and Threaded Adapter shall be either NPT or Metric thread forms. G1/2 and PG 13.5 thread forms are only acceptable for existing (legacy) equipment installations.

# Dimensional drawings

Figure 1. Rosemount 2090F

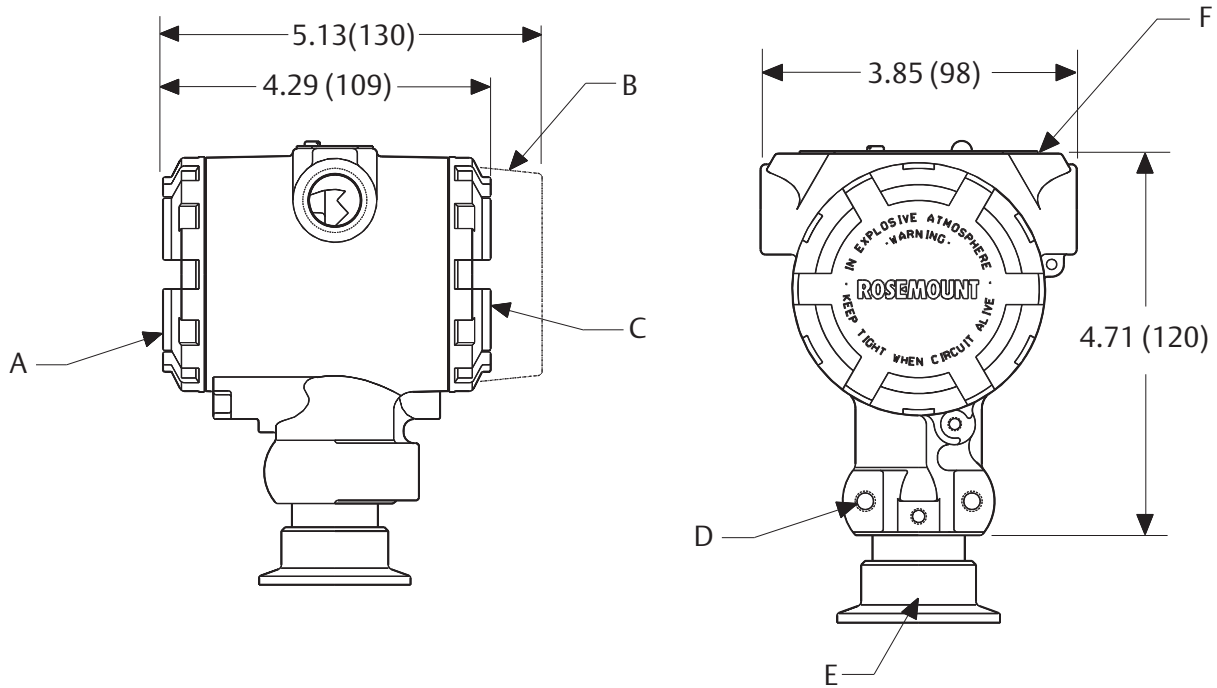

- A. Terminal connection side
- B. Optional display
- C. Transmitter circuitry side

- D.  $2 \times \frac{1}{4}$ -20 UNC-2BX depth 0.60 mounting holes
- E.  $1\frac{1}{2}$ - or 2-in. Tri Clamp connection
- F. Certification tag

Note: M20  $\times$  1.5 female is also available as option.













Dimensions are in inches (millimeters).



# HIGH ACCURACY

measurement instruments

Our offering:

	<p>Pressure Measurement</p>		<p>Level Measurement</p>
	<p>Temperature Measurement</p>		<p>Flow Measurement</p>
	<p>Marine Measurement &amp; Analytical</p>		<p>Gas Analysis</p>
	<p>Liquid Analysis</p>		<p>Flame and Gas Detection</p>
	<p>Tank Gauging</p>		<p>Wireless Infrastructure</p>
	<p>Acoustic &amp; Discrete</p>		

[www.high-accuracy.com](http://www.high-accuracy.com)

## Global Headquarters

### Emerson Automation Solutions

6021 Innovation Blvd.  
Shakopee, MN 55379, USA  
+1 800 999 9307 or +1 952 906 8888  
+1 952 949 7001  
RFQ.RMD-RCC@Emerson.com

## North America Regional Office

### Emerson Automation Solutions

8200 Market Blvd.  
Chanhassen, MN 55317, USA  
+1 800 999 9307 or +1 952 906 8888  
+1 952 949 7001  
RMT-NA.RCCRFQ@Emerson.com

## Latin America Regional Office

### Emerson Automation Solutions

1300 Concord Terrace, Suite 400  
Sunrise, FL 33323, USA  
+1 954 846 5030  
+1 954 846 5121  
RFQ.RMD-RCC@Emerson.com

## Europe Regional Office

### Emerson Automation Solutions Europe GmbH

Neuhofstrasse 19a P.O. Box 1046  
CH 6340 Baar  
Switzerland  
+41 (0) 41 768 6111  
+41 (0) 41 768 6300  
RFQ.RMD-RCC@Emerson.com

## Asia Pacific Regional Office

### Emerson Automation Solutions

1 Pandan Crescent  
Singapore 128461  
+65 6777 8211  
+65 6777 0947  
Enquiries@AP.Emerson.com

## Middle East and Africa Regional Office

### Emerson Automation Solutions

Emerson FZE P.O. Box 17033  
Jebel Ali Free Zone - South 2  
Dubai, United Arab Emirates  
+971 4 8118100  
+971 4 8865465  
RFQ.RMTMEA@Emerson.com

 [Linkedin.com/company/Emerson-Automation-Solutions](https://www.linkedin.com/company/Emerson-Automation-Solutions)

 [Twitter.com/Rosemount\\_News](https://twitter.com/Rosemount_News)

 [Facebook.com/Rosemount](https://www.facebook.com/Rosemount)

 [Youtube.com/user/RosemountMeasurement](https://www.youtube.com/user/RosemountMeasurement)

 [Google.com/+RosemountMeasurement](https://www.google.com/+RosemountMeasurement)

Emerson Terms and Conditions of Sale are available upon request.  
The Emerson logo is a trademark and service mark of Emerson Electric Co.  
Rosemount and Rosemount logotype are trademarks of Emerson.  
HART is a registered trademark of the FieldComm Group.  
3-A is a registered trademark of 3-A Sanitary Standards, Inc.  
NEMA is a registered trademark and service mark of the National  
Electrical Manufacturers Association, Inc.  
Neobee is a registered trademark of Stepan Specialty Products, LLC.  
All other marks are the property of their respective owners.  
© 2018 Emerson. All rights reserved.