



HIGH ACCURACY

m e a s u r e m e n t i n s t r u m e n t s

PRODUCT DATASHEET

www.high-accuracy.com

Rosemount™ 4088 MultiVariable™ Transmitter



With the innovative Rosemount 4088 MultiVariable Transmitter, you can maximize your measurement accuracy and output efficiency, not only today but over the life of your equipment. This versatile device provides a reliable, stable signal so you can achieve unmatched data accuracy and more effectively manage changing conditions to optimize profits. Because the Rosemount 4088 is easy to configure and calibrate, you can more quickly install new measurement points, reducing the time it takes to get up and running. It requires minimal maintenance over time, so your crews can focus on optimizing other aspects of your operation. When issues do arise, Emerson™ experts are readily available with fast, thorough support so you can get back to what you do best – producing and maximizing profit.

Rosemount 4088 product overview

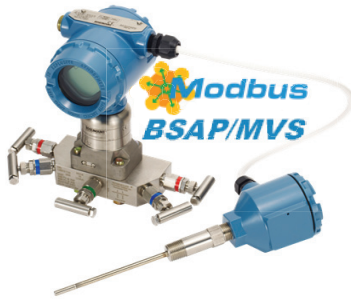

Industry leading performance and capabilities

Enabled by superior sensor technology and engineered for optimal flow performance, the Rosemount 4088 delivers unparalleled accuracy over a wide range of operating conditions. Superior performance results in better control of your operations and maximizes profits.

Flexible communications with Modbus® or Bristol™ Standard Asynchronous/Synchronous Protocol (BSAP)/MVS

Designed for easy integration with an existing or new system, the Rosemount 4088 can communicate using either Modbus or BSAP/MVS protocols. Baud rates up to 19200 allow flow computers to communicate with more speed and efficiency.

Writable display

The local LCD display of the Rosemount 4088 can show both measured data as well as flow computer calculations such as “Instantaneous Flow Rate” or “Last 24 hours of Accumulation Flow”. This simplifies maintenance and provides additional clarity into well operations.

Extended range for plunger lift measurement

Utilizing new sensor technology, the Rosemount 4088 Extended Range option ensures peak flows are captured, without sacrificing performance over the normal operating range. This helps eliminate accounting differences that can result in disputes.

Reduced power consumption

Advanced electronics within the Rosemount 4088 consume less power, meaning more transmitters can run on a single power supply or solar panel. Reverse wiring protection also ensures the transmitter will not be damaged if the power is incorrectly connected.

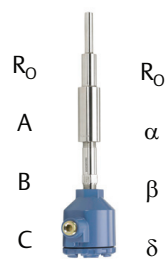
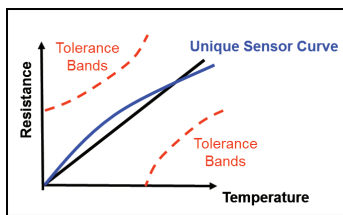
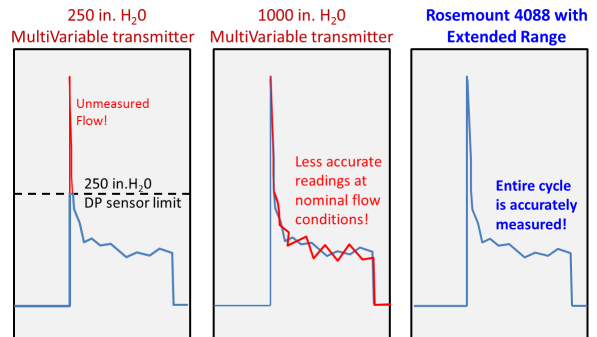

Accurate

RTD measurement through sensor matching

The Rosemount 4088 can make use of Callendar-Van Dusen constants to define the unique RTD characteristics, reducing process temperature error and flow error.

Seamless transition from legacy products

To ensure a smooth transition from Emerson legacy products, the Rosemount 4088 will communicate using the same protocols as a drop-in replacement. This will allow users to quickly change out legacy products for the Rosemount 4088, minimizing downtime and reducing engineering and installation costs.

Superior warranty and stability

The Rosemount 4088 offers long lasting performance, with up to a five-year stability specification and a 12-year warranty. This helps ensure that investments in Rosemount technology will continue to pay off for years to come.



3808



MVS 205



3095FB

Contents

Ordering information	3	Product Certifications	30
Specifications	18	Dimensional drawings	35

Ordering information

Specification and selection of product materials, options, or components must be made by the purchaser of the equipment. See [page 28](#) for more information on material selection.

Table 1. Rosemount 4088 MultiVariable Transmitter with Differential Pressure Sensor Configurations

The starred offerings (★) represent the most common options and should be selected for best delivery. The non-starred offerings are subject to additional delivery lead time.

Model	Transmitter type	
4088	Multivariable pressure transmitter	
Transmitter register mapping		
A	Modbus Protocol	★
B	Remote Automation Solutions ready	★
Performance class⁽¹⁾		
1	Enhanced: 0.075% span DP accuracy	★
3 ⁽²⁾	Enhanced for Flow: 0.05% reading DP accuracy	★
2	Standard: 0.1% span DP accuracy	★
Multivariable type		
P	Multivariable measurement with direct process variable output	★
Measurement type		
1	Differential pressure, static pressure, and temperature	★
2	Differential pressure and static pressure	★
3	Differential pressure and temperature	★
4	Differential pressure	★
Differential pressure range		
1	-25 to 25 inH ₂ O (-62,16 to 62,16 mbar)	★
2	-250 to 250 inH ₂ O (-621,60 to 621,60 mbar)	★
A ⁽³⁾	Extended range capability: 0 to 250 inH ₂ O (0 to 621,60 mbar)	★
3	-1000 to 1000 inH ₂ O (-2,49 to 2,49 bar)	★
4 ⁽⁴⁾	-150 to 150 psi (-10,34 to 10,34 bar) for measurement types 1 and 2; -300 to 300 psi (-20,68 to 20,68 bar) for measurement types 3 and 4	★
5 ⁽⁴⁾	-2000 to 2000 psi (-137,89 to 137,89 bar)	★
Static pressure type		
N ⁽⁵⁾	None	★
A	Absolute	★
G	Gage	★

Table 1. Rosemount 4088 MultiVariable Transmitter with Differential Pressure Sensor Configurations

The starred offerings (★) represent the most common options and should be selected for best delivery. The non-starred offerings are subject to additional delivery lead time.

Static pressure range		Absolute (A)	Gage (G)			
N ⁽⁵⁾	None					★
6 ⁽⁶⁾	Range 6	0.5 to 300 psia (0,03 to 20,68 bar)	-14.2 to 300 psi (-0,98 to 20,68 bar)			★
3 ⁽⁷⁾	Range 3	0.5 to 800 psia (0,03 to 55,15 bar)	-14.2 to 800 psi (-0,98 to 55,15 bar)			★
7 ⁽⁶⁾	Range 7	0.5 to 1500 psia (0,03 to 103,42 bar)	-14.2 to 1500 psi (-0,98 to 103,42 bar)			★
4 ⁽⁸⁾	Range 4	0.5 to 3626 psia (0,03 to 250,00 bar)	-14.2 to 3626 psi (-0,98 to 250,00 bar)			★
Temperature input						
N ⁽⁹⁾	None					★
R ⁽¹⁰⁾	RTD input (type Pt 100, -328 to 1562 °F [-200 to 850 °C])					★
Isolating diaphragm⁽¹¹⁾						
2	316L SST					★
3	Alloy C-276					★
Process connection	Conn size	Material type				
		Flange material	Drain vent	Bolting		
A11 ⁽¹²⁾⁽¹³⁾	Assemble to Rosemount 305 Integral Manifold					★
A12 ⁽¹²⁾	Assemble to Rosemount 304 or AMF manifold with 316 SST traditional flange					★
C11 ⁽¹²⁾	Assemble to Rosemount 405C or 405P Primary Element					★
D11 ⁽¹²⁾	Assemble to Rosemount 1195 Integral Orifice and 305 Manifold					★
EA2 ⁽¹²⁾	Assemble to Rosemount 485 or 405A Annubar™ Primary Element with coplanar flange	316 SST	316 SST	N/A		★
E11	Coplanar flange	1/4-18 NPT	Carbon Steel (CS)	316 SST	N/A	★
E12	Coplanar flange	1/4-18 NPT	316 SST	316 SST	N/A	★
E13 ⁽¹¹⁾	Coplanar flange	1/4-18 NPT	Cast C-276	Alloy C-276	N/A	★
E15 ⁽¹¹⁾	Coplanar flange	1/4-18 NPT	316 SST	Alloy C-276	N/A	★
E16 ⁽¹¹⁾	Coplanar flange	1/4-18 NPT	CS	Alloy C-276	N/A	★
F12	Traditional flange	1/4-18 NPT	316 SST	316 SST	N/A	★
F13 ⁽¹¹⁾	Traditional flange	1/4-18 NPT	Cast C-276	Alloy C-276	N/A	★
F15 ⁽¹¹⁾	Traditional flange	1/4-18 NPT	316 SST	Alloy C-276	N/A	★
F52	DIN-compliant traditional flange	1/4-18 NPT	316 SST	316 SST	7/16-in. bolting	★
Housing style		Conduit entry size				
1A	Polyurethane-covered aluminum housing		1/2-14 NPT			★
1B	Polyurethane-covered aluminum housing		M20 x 1.5 (CM20)			★
1J	SST housing		1/2-14 NPT			★
1K	SST housing		M20 x 1.5 (CM20)			★

Table 1. Rosemount 4088 MultiVariable Transmitter with Differential Pressure Sensor Configurations

The starred offerings (★) represent the most common options and should be selected for best delivery. The non-starred offerings are subject to additional delivery lead time.

Options (include with selected model number)

Extended product warranty					
WR3	Three-year limited warranty				★
WR5	Five-year limited warranty				★
RTD cable (RTD sensor must be ordered separately)		Cable length	Protection type		
C12	RTD input	12 ft. (3,66 m)	Shielded cable		★
C13	RTD input	24 ft. (7,32 m)	Shielded cable		★
C14	RTD input	75 ft. (22,86 m)	Shielded cable		★
C22	RTD input	12 ft. (3,66 m)	Armored shielded cable		★
C23	RTD input	24 ft. (7,32 m)	Armored shielded cable		★
C24	RTD input	75 ft. (22,86 m)	Armored shielded cable		★
C32	RTD input	12 ft. (3,66 m)	ATEX/IECEX flameproof cable		★
C33	RTD input	24 ft. (7,32 m)	ATEX/IECEX flameproof cable		★
C34	RTD input	75 ft. (22,86 m)	ATEX/IECEX flameproof cable		★
Mounting brackets⁽¹³⁾		Bracket material	Pipe/panel	Bolt material	
B4	Coplanar flange bracket	SST	2-in. pipe and panel	SST	★
B1	Traditional flange bracket	CS	2-in. pipe	N/A	★
B2	Traditional flange bracket	CS	Panel	N/A	★
B3	Traditional flange flat bracket	CS	2-in. pipe	N/A	★
B7	Traditional flange bracket B1	CS	2-in. pipe	SST	★
B8	Traditional flange bracket B2	CS	Panel	SST	★
B9	Traditional flange flat bracket B3	CS	2-in. pipe	SST	★
BA	Traditional flange bracket B1	SST	2-in. pipe	SST	★
BC	Traditional flange flat bracket B3	SST	2-in. pipe	SST	★
Software configuration⁽¹⁴⁾					
C1	Custom software configuration (A Configuration Data Sheet must be completed.)				★
Process adapters					
D2	1/2–14 NPT process adapters				★
Custody transfer					
D3	Measurement Canada Accuracy Approval				★
External ground screw assembly⁽¹⁵⁾					
D4	External ground screw assembly				★

Table 1. Rosemount 4088 MultiVariable Transmitter with Differential Pressure Sensor Configurations

The starred offerings (★) represent the most common options and should be selected for best delivery. The non-starred offerings are subject to additional delivery lead time.

Drain/vent valve⁽¹⁶⁾		
D5	Delete transmitter drain/vent valves (install plugs)	★
Conduit plug⁽¹⁷⁾		
DO	316 SST conduit plug	★
Product certifications⁽¹⁹⁾		
E1	ATEX Flameproof	★
I1	ATEX Intrinsic Safety	★
N1	ATEX Type n	★
ND	ATEX Dust	★
K1	ATEX Flameproof, Intrinsic Safety, Type n, Dust (combination of E1, I1, N1, and ND)	★
E5	FM Explosion-proof, Dust Ignition-proof, Division 2	★
I5	FM Intrinsically Safe, Division 2	★
K5	FM Explosion-proof, Dust Ignition-proof, Intrinsically Safe, Division 2 (combination of E5 and I5)	★
E6 ⁽¹⁸⁾	CSA Explosion-proof, Dust Ignition-proof, Division 2	★
I6	CSA Intrinsically Safe	★
K6 ⁽¹⁸⁾	CSA Explosion-proof, Dust Ignition-proof, Intrinsically Safe, Division 2 (combination of E6 and I6)	★
E7	IECEX Flameproof	★
I7	IECEX Intrinsic Safety	★
N7	IECEX Type n	★
K7	IECEX Flameproof, Intrinsic Safety, and Type n (combination of E7, I7, and N7)	★
E2	INMETRO Flameproof	★
I2	INMETRO Intrinsic Safety	★
K2	INMETRO Flameproof, Intrinsic Safety (combination of E2 and I2)	★
KA ⁽¹⁸⁾	ATEX and CSA Explosion-proof, Intrinsically Safe, Division 2 (combination E1, E6, I1, and I6)	★
KB ⁽¹⁸⁾	FM and CSA Explosion-proof, Dust Ignition-proof, Intrinsically Safe, Division 2 (combination E5, I5, E6, and I6)	★
KC	FM and ATEX Explosion-proof, Intrinsically Safe, Division 2 (combination E5, I5, E1, and I1)	★
KD ⁽¹⁸⁾	FM, CSA, and ATEX Explosion-proof, Intrinsically Safe (combination E5, E6, E1, I5, I6, and I1)	★
Sensor fill fluid		
L1	Inert sensor fill fluid (not available with an absolute static pressure type)	★
O-ring		
L2	Graphite-filled PTFE O-ring	★

Table 1. Rosemount 4088 MultiVariable Transmitter with Differential Pressure Sensor Configurations

The starred offerings (★) represent the most common options and should be selected for best delivery. The non-starred offerings are subject to additional delivery lead time.

Bolting material		
L4	Austenitic 316 SST bolts	★
L5	ASTM A193, Grade B7M bolts	★
L6	Alloy K-500 bolts	★
L7	ASTM A453, Class D, Grade 660 bolts	★
L8	ASTM A193, Class 2, Grade B8M bolts	★
Digital display		
M5	LCD display	★
Housing cover extension		
HX	Extended housing cover	★
Pressure testing		
P1	Hydrostatic testing with certificate	★
Cleaning process area⁽¹⁶⁾		
P2	Cleaning for special services	
P3	Cleaning for special services with testing for <1PPM chlorine/fluorine	
Maximum static line pressure⁽²¹⁾		
P9	4500 psi (310 bar) static pressure limit	★
P0	6092 psi (420 bar) static pressure limit	★
Calibration data certification		
Q4	Calibration certificate	★
QP	Calibration certificate and tamper evident seal	★
Material traceability certification		
Q8	Material traceability certification per EN 10204 3.1B	★
NACE® certificates⁽²⁰⁾		
Q15	Certificate of compliance to NACE MR0175/ISO15156 for wetted materials	★
Q25	Certificate of compliance to NACE MR0103 for wetted materials	★
Terminal block		
T1	Transient terminal block	★
Cold temperature		
BRR	-58 °F (-50 °C) cold temperature start-ups	★
Typical model numbers:	4088 A 1 P 1 2 G 7 R 2 A11 1A C12 C1 K5 M5 Q4 Q8 T1	
	4088 B 1 P 1 2 G 7 R 2 A11 1A C12 C1 K5 Q4 Q8 T1	

1. For detailed specifications see ["Performance specifications" Section on page 18.](#)
2. Performance class 3 is only available with DP Range 2, 3, and 4. DP Range 4 with performance class 3 is only available with measurement type 1 or 2.
3. DP Range A is only available with performance class 1 and measurement types 1 and 2.
4. Only available with static pressure ranges N and 4.
5. Required for measurement types 3 and 4.
6. SP Ranges 6 and 7 are only available with measurement types 1 or 2 and DP Range 2, 3, or A.
7. Available with measurement types 1 and 2, DP Range 1, and performance class 1 or 2 only.
8. Only available with measurement types 1 and 2. With DP range 1, absolute limits are 0.5 to 2000 psi (0,03 to 137,89 bar) and gage limits are -14.2 to 2000 psi (-0,98 to 137,89 bar).
9. Required for measurement types 2 and 4.
10. Required for measurement types 1 and 3. RTD sensor must be ordered separately.
11. Materials of construction comply with metallurgical requirements highlighted within NACE MR0175/ISO 15156 for sour oil field production environments. Environmental limits apply to certain materials. Consult latest standard for details. Selected materials also conform to NACE MR0103 for sour refining environments. Order with Q15 or Q25 to receive a NACE certificate.
12. "Assemble to" items are specified separately and require a completed model number
13. For process connection option code A11, the mounting bracket must be ordered as part of the manifold model number.
14. Not available for Rosemount 4088B.
15. This assembly is included with certification options E1, N1, K1, ND, E7, N7, K7, E2, K2, KA, KC, and KD.
16. Not available with process connection option code A11.
17. Transmitter is shipped with 316 SST conduit plug (uninstalled) in place of standard CS conduit plug.
18. Not available with M20 conduit entry size.
19. Product certifications will not drive explosion-proof RTD cable fitting, glands, or adapters.
20. NACE compliant wetted materials are identified by [Footnote 11.](#)
21. Requires measurement type 3 or 4.

Specification and selection of product materials, options, or components must be made by the purchaser of the equipment. See [page 28](#) for more information on material selection.

Table 2. Rosemount 4088 MultiVariable Transmitter with Coplanar™ Static Pressure Sensor Configurations

The starred offerings (★) represent the most common options and should be selected for best delivery. The non-starred offerings are subject to additional delivery lead time.

Model	Transmitter type			
Rosemount 4088	Multivariable pressure transmitter			
Transmitter register mapping				
A	Modbus Protocol			★
B	Remote Automation Solutions ready			★
Performance class⁽¹⁾				
1	Enhanced: 0.075% span accuracy			★
2	Standard: 0.1% span accuracy			★
MultiVariable type				
P	Multivariable measurement with direct process variable output			★
Measurement type				
5	Static pressure and temperature - coplanar style			★
7	Static pressure - coplanar style			★
Differential pressure range				
N	None			★
Static pressure type				
A	Absolute			★
G	Gage			★
Static pressure range		Absolute (A)	Gage (G)	
0	Range 0	0 to 5 psia (0 to 0,34 bar)	N/A	★
1	Range 1	0 to 30 psia (0 to 2,06 bar)	-25 to 25 inH ₂ O (-62,16 to 62,16 mbar)	★
2	Range 2	0 to 150 psia (0 to 10,34 bar)	-250 to 250 inH ₂ O (-621,60 to 621,60 mbar)	★
3	Range 3	0 to 800 psia (0 to 55,15 bar)	-393 to 1000 inH ₂ O (-0,98 to 2,49 bar)	★
4	Range 4	0 to 4000 psia (0 to 275,79 bar)	-14.2 to 300 psi (-0,98 to 20,68 bar)	★
5	Range 5	N/A	-14.2 to 2000 psi (-0,98 to 137,89 bar)	★
Temperature input				
N ⁽²⁾	None			★
R ⁽³⁾	RTD input (type Pt 100, -328 to 1562 °F [-200 to 850 °C])			★
Isolating diaphragm⁽⁴⁾				
2	316L SST			★
3	Alloy C-276			★

Table 2. Rosemount 4088 MultiVariable Transmitter with Coplanar™ Static Pressure Sensor Configurations

The starred offerings (★) represent the most common options and should be selected for best delivery. The non-starred offerings are subject to additional delivery lead time.

Process connection		Conn size	Material type			
			Flange material	Drain vent	Bolting	
A11 ⁽⁵⁾⁽⁶⁾	Assemble to Rosemount 305 Manifold Integral Manifold					★
A12 ⁽⁵⁾	Assemble to Rosemount 304 or AMF Manifold with 316 SST traditional flange					★
E11	Coplanar flange	1/4–18 NPT	CS	316 SST	N/A	★
E12	Coplanar flange	1/4–18 NPT	316 SST	316 SST	N/A	★
E13 ⁽⁴⁾	Coplanar flange	1/4–18 NPT	Cast C-276	Alloy C-276	N/A	★
E15 ⁽⁴⁾	Coplanar flange	1/4–18 NPT	316 SST	Alloy C-276	N/A	★
E16 ⁽⁴⁾	Coplanar flange	1/4–18 NPT	CS	Alloy C-276	N/A	★
F12	Traditional flange	1/4–18 NPT	316 SST	316 SST	N/A	★
F13 ⁽⁴⁾	Traditional flange	1/4–18 NPT	Cast C-276	Alloy C-276	N/A	★
F15 ⁽⁴⁾	Traditional flange	1/4–18 NPT	316 SST	Alloy C-276	N/A	★
F52	DIN-compliant traditional flange	1/4–18 NPT	316 SST	316 SST	7/16-in. bolting	★
Housing style				Conduit entry size		
1A	Polyurethane-covered aluminum housing			1/2–14 NPT		★
1B	Polyurethane-covered aluminum housing			M20 x 1.5 (CM20)		★
1J	SST housing			1/2–14 NPT		★
1K	SST housing			M20 x 1.5 (CM20)		★

Options (include with selected model number)

Extended product warranty						
WR3	Three-year limited warranty					★
WR5	Five-year limited warranty					★
RTD cable (RTD sensor must be ordered separately)		Cable length	Protection type			
C12	RTD input	12 ft. (3,66 m)	Shielded cable			★
C13	RTD input	24 ft. (7,32 m)	Shielded cable			★
C14	RTD input	75 ft. (22,86 m)	Shielded cable			★
C22	RTD input	12 ft. (3,66 m)	Armored shielded cable			★
C23	RTD input	24 ft. (7,32 m)	Armored shielded cable			★
C24	RTD input	75 ft. (22,86 m)	Armored shielded cable			★
C32	RTD input	12 ft. (3,66 m)	ATEX/IECEX flameproof cable			★
C33	RTD input	24 ft. (7,32 m)	ATEX/IECEX flameproof cable			★
C34	RTD input	75 ft. (22,86 m)	ATEX/IECEX flameproof cable			★

Table 2. Rosemount 4088 MultiVariable Transmitter with Coplanar™ Static Pressure Sensor Configurations

The starred offerings (★) represent the most common options and should be selected for best delivery. The non-starred offerings are subject to additional delivery lead time.

Mounting brackets ⁽⁶⁾		Bracket material	Pipe/panel	Bolt material	
B4	Coplanar flange bracket	SST	2-in. pipe and panel	SST	★
B1	Traditional flange bracket	CS	2-in. pipe	N/A	★
B2	Traditional flange bracket	CS	Panel	N/A	★
B3	Traditional flange flat bracket	CS	2-in. pipe	N/A	★
B7	Traditional flange bracket B1	CS	2-in. pipe	SST	★
B8	Traditional flange bracket B2	CS	Panel	SST	★
B9	Traditional flange flat bracket B3	CS	2-in. pipe	SST	★
BA	Traditional flange bracket B1	SST	2-in. pipe	SST	★
BC	Traditional flange flat bracket B3	SST	2-in. pipe	SST	★
Software configuration⁽⁷⁾					
C1	Custom software configuration (A Configuration Data Sheet must be completed.)				★
Process adapters					
D2	1/2–14 NPT process adapters				★
Custody transfer					
D3	Measurement Canada Accuracy Approval				★
External ground screw assembly⁽⁸⁾					
D4	External ground screw assembly				★
Drain/vent valve⁽¹²⁾					
D5	Delete transmitter drain/vent valves (install plugs)				★
Conduit plug⁽⁹⁾					
DO	316 SST conduit plug				★
Product certifications⁽¹¹⁾					
E1	ATEX Flameproof				★
I1	ATEX Intrinsic Safety				★
N1	ATEX Type n				★
ND	ATEX Dust				★
K1	ATEX Flameproof, Intrinsic Safety, Type n, Dust (combination of E1, I1, N1, and ND)				★
E5	FM Explosion-proof, Dust Ignition-proof, Division 2				★
I5	FM Intrinsically Safe, Division 2				★
K5	FM Explosion-proof, Dust Ignition-proof, Intrinsically Safe, Division 2 (combination of E5 and I5)				★

Table 2. Rosemount 4088 MultiVariable Transmitter with Coplanar™ Static Pressure Sensor Configurations

The starred offerings (★) represent the most common options and should be selected for best delivery. The non-starred offerings are subject to additional delivery lead time.

E6 ⁽¹⁰⁾	CSA Explosion-proof, Dust Ignition-proof, Division 2	★
I6	CSA Intrinsically Safe	★
K6 ⁽¹⁰⁾	CSA Explosion-proof, Dust Ignition-proof, Intrinsically Safe, Division 2 (combination of E6 and I6)	★
E7	IECEX Flameproof	★
I7	IECEX Intrinsic Safety	★
N7	IECEX Type n	★
K7	IECEX Flameproof, Intrinsic Safety, and Type n (combination of E7, I7, and N7)	★
E2	INMETRO Flameproof	★
I2	INMETRO Intrinsic Safety	★
K2	INMETRO Flameproof, Intrinsic Safety (combination of E2 and I2)	★
KA ⁽¹⁰⁾	ATEX & CSA Explosion-proof, Intrinsically Safe, Division 2 (combination E1, E6, I1, and I6)	★
KB ⁽¹⁰⁾	FM & CSA Explosion-proof, Dust Ignition-proof, Intrinsically Safe, Division 2 (combination E5, I5, E6, and I6)	★
KC	FM & ATEX Explosion-proof, Intrinsically Safe, Division 2 (combination E5, I5, E1, and I1)	★
KD ⁽¹⁰⁾	FM, CSA, & ATEX Explosion-proof, Intrinsically Safe (combination E5, E6, E1, I5, I6, and I1)	★
Sensor fill fluid		
L1	Inert sensor fill fluid (not available with an absolute static pressure type)	★
O-ring		
L2	Graphite-filled PTFE O-ring	★
Bolting material		
L4	Austenitic 316 SST bolts	★
L5	ASTM A193, Grade B7M bolts	★
L6	Alloy K-500 bolts	★
L7	ASTM A453, Class D, Grade 660 bolts	★
L8	ASTM A193, Class 2, Grade B8M bolts	★
Digital display		
M5	LCD display	★
Housing cover extension		
HX	Extended housing cover	★
Pressure testing		
P1	Hydrostatic testing with certificate	★
Cleaning process area⁽¹²⁾		
P2	Cleaning for special services	
P3	Cleaning for special services with testing for <1PPM chlorine/fluorine	

Table 2. Rosemount 4088 MultiVariable Transmitter with Coplanar™ Static Pressure Sensor Configurations

The starred offerings (★) represent the most common options and should be selected for best delivery. The non-starred offerings are subject to additional delivery lead time.

Calibration data certification		
Q4	Calibration certificate	★
QP	Calibration certificate and tamper evident seal	★
Material traceability certification		
Q8	Material traceability certification per EN 10204 3.1B	★
NACE certificates ⁽¹³⁾		
Q15	Certificate of compliance to NACE MR0175/ISO15156 for wetted materials	★
Q25	Certificate of compliance to NACE MR0103 for wetted materials	★
Terminal block		
T1	Transient terminal block	★
Cold temperature		
BRR	-58 °F (-50 °C) cold temperature start-up	★
Typical model numbers:	4088 A 1 P 5 N G 2 R 2 E11 1A C12 B4 E5 M5	
	4088 B 1 P 5 N G 2 R 2 E11 1A C12 B4 E5 M5	

- For detailed specifications see "Performance specifications" Section on page 18.
- Required for measurement type 7.
- Required for measurement type 5. RTD Sensor must be ordered separately.
- Materials of Construction comply with metallurgical requirements highlighted within NACE MR0175/ISO 15156 for sour oil field production environments. Environmental limits apply to certain materials. Consult latest standard for details. Selected materials also conform to NACE MR0103 for sour refining environments. Order with Q15 or Q25 to receive a NACE certificate.
- "Assemble to" items are specified separately and require a completed model number.
- For process connection option code A11, the mounting bracket must be ordered as part of the manifold model number.
- Not available for Rosemount 4088B.
- This assembly is included with certification options E1, N1, K1, ND, E7, N7, K7, E2, K2, KA, KC, and KD.
- Transmitter is shipped with 316 SST conduit plug (uninstalled) in place of standard CS conduit plug.
- Not available with M20 conduit entry size.
- Product certifications will not drive explosion-proof RTD cable fitting, glands, or adapters.
- Not available with process connection A11.
- NACE compliant wetted materials are identified by [Footnote 4](#).

Specification and selection of product materials, options, or components must be made by the purchaser of the equipment. See [page 28](#) for more information on material selection.

Table 3. Rosemount 4088 MultiVariable Transmitter with In-line Static Pressure Sensor Configurations

The starred offerings (★) represent the most common options and should be selected for best delivery. The non-starred offerings are subject to additional delivery lead time.

Model	Transmitter type		
4088	Multivariable pressure transmitter		
Transmitter register mapping			
A	Modbus Protocol		★
B	Remote Automation Solutions ready		★
Performance class⁽¹⁾			
1	Enhanced: 0.075% span accuracy		★
2	Standard: 0.1% span accuracy		★
MultiVariable type			
P	Multivariable measurement with direct process variable output		★
Measurement type			
6	Static pressure and temperature, in-line style		★
8	Static pressure, in-line style		★
Differential pressure range			
N	None		★
Static pressure type			
A	Absolute		★
G	Gage		★
Static pressure range		Absolute (A)	Gage (G)
1	Range 1	0 to 30 psia (0 to 2,06 bar)	-14.7 to 30 psi (-1,01 to 2,06 bar) ★
2	Range 2	0 to 150 psia (0 to 10,34 bar)	-14.7 to 150 psi (-1,01 to 10,34 bar) ★
3	Range 3	0 to 800 psia (0 to 55,15 bar)	-14.7 to 800 psi (-1,01 to 55,15 bar) ★
4	Range 4	0 to 4000 psia (0 to 275,79 bar)	-14.7 to 4000 psi (-1,01 to 275,79 bar) ★
5	Range 5	0 to 10000 psia (0 to 689,47 bar)	-14.7 to 10000 psi (-1,01 to 689,47 bar) ★
Temperature input			
N ⁽²⁾	None		★
R ⁽³⁾	RTD input (type Pt 100, -328 to 1562 °F [-200 to 850 °C])		★
Isolating diaphragm⁽⁴⁾			
2	316L SST		★
3	Alloy C-276		★

Table 3. Rosemount 4088 MultiVariable Transmitter with In-line Static Pressure Sensor Configurations

The starred offerings (★) represent the most common options and should be selected for best delivery. The non-starred offerings are subject to additional delivery lead time.

Process connection			
A11 ⁽⁵⁾	Assemble to Rosemount 306 Manifold Integral Manifold		★
K11	1/2–14 NPT female		★
Housing style		Conduit entry size	
1A	Polyurethane-covered aluminum housing	1/2–14 NPT	★
1B	Polyurethane-covered aluminum housing	M20 x 1.5 (CM20)	★
1J	SST housing	1/2–14 NPT	★
1K	SST housing	M20 x 1.5 (CM20)	★

Options (include with selected model number)

Extended product warranty			
WR3	3-year limited warranty		★
WR5	5-year limited warranty		★
RTD cable (RTD Sensor must be ordered separately)		Cable length	Protection type
C12	RTD input	12 ft. (3,66 m)	Shielded cable
C13	RTD input	24 ft. (7,32 m)	Shielded cable
C14	RTD input	75 ft. (22,86 m)	Shielded cable
C22	RTD input	12 ft. (3,66 m)	Armored shielded cable
C23	RTD input	24 ft. (7,32 m)	Armored shielded cable
C24	RTD input	75 ft. (22,86 m)	Armored shielded cable
C32	RTD input	12 ft. (3,66 m)	ATEX/IECEX flameproof cable
C33	RTD input	24 ft. (7,32 m)	ATEX/IECEX flameproof cable
C34	RTD input	75 ft. (22,86 m)	ATEX/IECEX flameproof cable
Software configuration ⁽⁶⁾			
C1	Custom software configuration (A Configuration Data Sheet must be completed.)		★
Custody transfer			
D3	Measurement Canada Accuracy Approval		★
External ground screw assembly ⁽⁷⁾			
D4	External ground screw assembly		★
Drain/vent valve ⁽¹¹⁾			
D5	Delete transmitter drain/vent valves (install plugs)		★

Table 3. Rosemount 4088 MultiVariable Transmitter with In-line Static Pressure Sensor Configurations

The starred offerings (★) represent the most common options and should be selected for best delivery. The non-starred offerings are subject to additional delivery lead time.

Conduit plug⁽⁸⁾		
DO	316 SST conduit plug	★
Product certifications⁽⁹⁾		
E1	ATEX Flameproof	★
I1	ATEX Intrinsic Safety	★
N1	ATEX Type n	★
ND	ATEX Dust	★
K1	ATEX Flameproof, Intrinsic Safety, Type n, Dust (combination of E1, I1, N1, and ND)	★
E5	FM Explosion-proof, Dust Ignition-proof, Division 2	★
I5	FM Intrinsically Safe, Division 2	★
K5	FM Explosion-proof, Dust Ignition-proof, Intrinsically Safe, Division 2 (combination of E5 and I5)	★
E6 ⁽¹⁰⁾	CSA Explosion-proof, Dust Ignition-proof, Division 2	★
I6	CSA Intrinsically Safe	★
K6 ⁽¹⁰⁾	CSA Explosion-proof, Dust Ignition-proof, Intrinsically Safe, Division 2 (combination of E6 and I6)	★
E7	IECEX Flameproof	★
I7	IECEX Intrinsic Safety	★
N7	IECEX Type n	★
K7	IECEX Flameproof, Intrinsic Safety, and Type n (combination of E7, I7, and N7)	★
E2	INMETRO Flameproof	★
I2	INMETRO Intrinsic Safety	★
K2	INMETRO Flameproof, Intrinsic Safety (combination of E2 and I2)	★
KA ⁽¹⁰⁾	ATEX & CSA Explosion-proof, Intrinsically Safe, Division 2 (combination E1, E6, I1, and I6)	★
KB ⁽¹⁰⁾	FM & CSA Explosion-proof, Dust Ignition-proof, Intrinsically Safe, Division 2 (combination E5, I5, E6, and I6)	★
KC	FM & ATEX Explosion-proof, Intrinsically Safe, Division 2 (combination E5, I5, E1, and I1)	★
KD ⁽¹⁰⁾	FM, CSA, & ATEX Explosion-proof, Intrinsically Safe (combination E5, E6, E1, I5, I6, and I1)	★
Sensor fill fluid		
L1	Inert sensor fill fluid (not available with an absolute static pressure type)	★
Digital display		
M5	LCD display	★
Housing cover extension		
HX	Extended housing cover	★
Pressure testing		
P1	Hydrostatic testing with certificate	★

Table 3. Rosemount 4088 MultiVariable Transmitter with In-line Static Pressure Sensor Configurations

The starred offerings (★) represent the most common options and should be selected for best delivery. The non-starred offerings are subject to additional delivery lead time.

Cleaning process area ⁽¹¹⁾		
P2	Cleaning for special services	
P3	Cleaning for special services with testing for <1PPM chlorine/fluorine	
Calibration data certification		
Q4	Calibration certificate	★
QP	Calibration certificate and tamper evident seal	★
Material traceability certification		
Q8	Material traceability certification per EN 10204 3.1B	★
NACE certificates ⁽¹²⁾		
Q15	Certificate of compliance to NACE MR0175/ISO15156 for wetted materials	★
Q25	Certificate of compliance to NACE MR0103 for wetted materials	★
Terminal block		
T1	Transient terminal block	★
Cold temperature		
BRR	-58 °F (-50 °C) cold temperature start-up	★
Typical model numbers:	4088 A 1 P 6 N G 2 R 2 K11 1A C12 E5 M5	
	4088 B 1 P 6 N G 2 R 2 K11 1A C12 E5 M5	

- For detailed specifications see "Performance specifications" Section on page 18.
- Required for measurement type 8.
- Required for measurement type 6. RTD sensor must be ordered separately.
- Materials of construction comply with metallurgical requirements highlighted within NACE MR0175/ISO 15156 for sour oil field production environments. Environmental limits apply to certain materials. Consult latest standard for details. Selected materials also conform to NACE MR0103 for sour refining environments. Order with Q15 or Q25 to receive a NACE certificate.
- "Assemble to" items are specified separately and require a completed model number.
- Not available for Rosemount 4088B.
- This assembly is included with certification options E1, N1, K1, ND, E7, N7, K7, E2, K2, KA, KC, and KD.
- Transmitter is shipped with 316 SST conduit plug (uninstalled) in place of standard CS conduit plug.
- Product certifications will not drive explosion-proof RTD cable fitting, glands, or adapters.
- Not available with M20 conduit entry size.
- Not available with Process Connection A11.
- NACE compliant wetted materials are identified by [Footnote 4](#)

Specifications

Performance specifications

For zero-based spans, reference conditions, silicone oil fill, glass-filled PTFE O-rings, SST materials, coplanar flange or 1/2 – 14 NPT process connections, digital trim values set to equal range points.

Conformance to specification ($\pm 3\sigma$ [sigma])

Technology leadership, advanced manufacturing techniques, and statistical process control ensure pressure measurement specification conformance to $\pm 3\sigma$ or better.

Reference accuracy

Stated reference accuracy equations include terminal based linearity, hysteresis, and repeatability.

Table 4. Rosemount MultiVariable and Differential Pressure Sensor Configurations (Measurement Types 1, 2, 3, and 4)

Range	Standard	Enhanced	Enhanced for Flow
DP			
1	$\pm 0.1\%$ span; For spans less than 5:1, $\pm(0.025 + 0.015 [\text{USL}/\text{Span}])\%$ span	$\pm 0.1\%$ span; For spans less than 15:1, $\pm(0.025 + 0.005 [\text{USL}/\text{Span}])\%$ span	N/A
2–3	$\pm 0.1\%$ span; For spans less than 10:1, $\pm(0.01 [\text{USL}/\text{Span}])\%$ span	$\pm 0.075\%$ span; For spans less than 10:1, $\pm(0.025 + 0.005 [\text{USL}/\text{Span}])\%$ span	$\pm 0.05\%$ reading; For readings less than 8:1, $\pm(0.05 + 0.0023 [\text{USL}/\text{Rdg}])\%$ reading
4 ⁽¹⁾			$\pm 0.05\%$ reading; For readings less than 3:1, $\pm(0.05 + 0.00245 [\text{USL}/\text{Rdg}])\%$ reading ⁽²⁾
5 ⁽¹⁾			
Extended range (code A)	N/A	$\pm 0.075\%$ span for spans 25 to 250 inH ₂ O; For readings above span, $\pm 0.15\%$ reading	N/A
AP and GP			
3, 4, 6, and 7	$\pm 0.1\%$ span; For spans less than 5:1, $\pm(0.017 [\text{USL}/\text{Span}])\%$ span	$\pm 0.075\%$ span; For spans less than 5:1, $\pm(0.013 [\text{USL}/\text{Span}])\%$ span	$\pm 0.05\%$ span; For spans less than 5:1, $\pm(0.006 [\text{USL}/\text{Span}])\%$ span

1. For measurement types 1 and 2 with Ranges 4 or 5, only available in Alloy C-276.

2. Only available with measurement types 1 and 2.

Table 5. Static Pressure Sensor Configurations (Measurement Types 5, 6, 7, and 8)

Range	Standard	Enhanced
0–5	$\pm 0.1\%$ span; For spans less than 10:1, $\pm(0.01 [\text{USL}/\text{Span}])\%$ span	$\pm 0.075\%$ span; For spans less than 10:1, $\pm(0.025 + 0.005 [\text{USL}/\text{Span}])\%$ span

**Table 6. Process Temperature Measurement Accuracy
(Excludes RTD Sensor Error)**

Range	RTD reference accuracy
-200 to 850 °C	±0.56 °C
0 to 60 °C	±0.1 °C

Long-term stability

Models ⁽¹⁾	Standard	Enhanced/enhanced for flow
All Rosemount 4088 products	±0.1% USL for 1 year	±0.125% USL for five-years; for ±50 °F (28 °C) temperature changes, up to 1000 psi (68,9 bar) line pressure

1. For measurement types 1 and 2 with DP range 1 and measurement types 5 and 7 with range 0 (absolute) and range 1 (gage); ±0.2 percent USL for 1 year.

Process temperature

Temperature element ⁽¹⁾	Specification
RTD Interface	±1.00 °F (0.56 °C) per year (excludes RTD sensor stability)

1. Specifications for process temperature are for the transmitter portion only. The transmitter is compatible with any Pt 100 (100 ohm platinum) RTD. Examples of compatible RTDs include the Rosemount Series 68 and 78 RTD temperature sensors.

Warranty

Models	Standard and Enhanced	Enhanced for Flow
All Rosemount 4088 products ⁽¹⁾	1-year limited warranty ⁽²⁾	12-year limited warranty ⁽³⁾

- Warranty details can be found in Emerson Terms & Conditions of Sale, Document 63445.
- Goods are warranted for 12 months from the date of initial installation or 18 months from the date of shipment by seller, whichever period expires first.
- Rosemount Enhanced for Flow Transmitters have a limited warranty of 12 years from date of shipment. All other provisions of Emerson standard limited warranty remain the same.

Ambient temperature effect

Temperature effect is defined as output at a given temperature minus the output at reference operating conditions, measured in ± percent of USL deviation per 50 °F (28 °C) change from reference operating conditions. Specifications apply only over the ambient temperature limits.

Table 7. Rosemount MultiVariable and Differential Pressure Sensor Configurations (Measurement Types 1, 2, 3, and 4)

Range	Standard	Enhanced	Enhanced for flow
DP	per 50 °F (28 °C)		
1	±(0.2% USL + 0.25% span) from 1:1 to 30:1, ±(0.24% USL + 0.15% span) from 30:1 to 50:1	±(0.1% USL + 0.25% span) from 1:1 to 30:1, ±(0.125% USL + 0.15% span) from 30:1 to 50:1	N/A
2-3	±(0.15% USL) from 1:1 to 30:1, ±(0.20% USL) from 30:1 to 50:1	±(0.0175% USL + 0.1% span) from 1:1 to 5:1, ±(0.035% USL + 0.125% span) from 5:1 to 100:1	±0.13% reading from 1:1 to 5:1, ±(0.13 + 0.04 [USL/RDG])% reading from 5:1 to 100:1

Table 7. Rosemount MultiVariable and Differential Pressure Sensor Configurations (Measurement Types 1, 2, 3, and 4)

Range	Standard	Enhanced	Enhanced for flow
DP	per 50 °F (28 °C)		
Extended range (code A) ⁽¹⁾⁽²⁾	N/A	For units spanned 75 to 250 inH ₂ O, ±(0.025% MSL + 0.125% span) For pressures between span and 250 inH ₂ O, ±(0.025% MSL + 0.125% reading)	N/A
		For units spanned 25 to 75 inH ₂ O, ±(0.09% MSL + 0.03% span) For pressures between span and 250 inH ₂ O, ±(0.09% MSL + 0.03% reading)	
		For pressure readings above 250 inH ₂ O, ±0.15% reading	
4–5 ⁽³⁾	±(0.225% USL) from 1:1 to 50:1	±(0.04% USL + 0.175% span) from 1:1 to 100:1	N/A
AP/GP⁽²⁾	per 50 °F (28 °C)		
3, 4, 6, and 7	±(0.175% USL) from 1:1 to 10:1, ±(0.225% USL) from 10:1 to 25:1	±(0.050% USL + 0.125% span) from 1:1 to 10:1, ±(0.060% USL + 0.175% span) from 10:1 to 40:1	±(0.040% USL + 0.060% span) from 1:1 to 10:1, ±(0.050% USL + 0.150% span) from 10:1 to 40:1

1. For extended range (code A), the Maximum Span Limit (MSL) of 250 inH₂O (621,60 mbar).
2. Only available with measurement types 1 and 2.
3. For measurement types 1 and 2 with Ranges 4 or 5, only available in Alloy C-276.

Table 8. Static Pressure Sensor Configurations (Measurement Types 5, 6, 7, and 8)

Range	Standard	Enhanced
Coplanar		
0	±(0.25% USL + 0.1% span)	±(0.25% USL + 0.1% span)
1	±(0.2% USL + 0.25% span) from 1:1 to 30:1, ±(0.24% USL + 0.15% span) from 30:1 to 50:1	±(0.1% USL + 0.25% span) from 1:1 to 30:1, ±(0.125% USL + 0.15% span) from 30:1 to 50:1
2–5	±(0.15% USL) from 1:1 to 30:1, ±(0.20% USL) from 30:1 to 50:1	±(0.025% USL + 0.125% span) from 1:1 to 30:1, ±(0.035% USL + 0.175% span) from 30:1 to 100:1
In-line		
1–4	±(0.175% USL) from 1:1 to 30:1, ±(0.225% USL) for 30:1 to 50:1	±(0.050% USL + 0.125% span) from 1:1 to 30:1, ±(0.060% USL + 0.175% span) for 30:1 to 100:1
5	±(0.05% USL + 0.075% span) for spans above 4000 psi	±(0.05% USL + 0.075% span) for spans above 2000 psi

Table 9. Temperature Effects for RTD Interface (Excludes RTD Sensor Error)

Range	Ambient temperature effect
–200 to 850 °C	±0.40 per 28 °C change
0 to 60 °C	±0.28 per 28 °C change

Line pressure effect⁽¹⁾

Range	Standard	Enhanced and enhanced for flow
Zero error⁽²⁾		
2–3 and extended range (code A) ⁽³⁾	±0.1% USL per 1000 psi (69 bar) For Static Pressures above 2000 psi: ±(0.2 + 0.0001 x [Ps – 2000])% / 1000 psi	±0.05% USL per 1000 psi (69 bar) For Static Pressures above 2000 psi: ±(0.1 + 0.0001 x [Ps – 2000])% / 1000 psi
1	±0.25% USL per 1000 psi (69 bar)	±0.25% USL per 1000 psi (69 bar)
Span error⁽⁴⁾		
2–3 and extended range (code A)	±0.2% USL per 1000 psi (69 bar)	±0.2% USL per 1000 psi (69 bar)
1	±0.4% USL per 1000 psi (69 bar)	±0.4% USL per 1000 psi (69 bar)

- For line pressure specifications for DP Ranges 4 and 5, see the Rosemount 4088 [Reference Manual](#).
- Zero error can be removed by performing a zero trim at line pressure.
- For extended range (code A), USL is the MSL of 250 inH₂O (621,60 mbar).
- Specifications for option code P0 are two times those shown above for Range 2.

Vibration effect

Aluminum housing

Less than ±0.1% USL when tested per the requirements of IEC60770-1:1999 field or pipeline with high vibration level (10–60 Hz 0.21 mm displacement peak amplitude/ 60–2000 Hz 3g).

SST housing

Less than ±0.1% USL when tested per the requirements of IEC60770-1:1999 field with general application or pipeline with low vibration level (10–60 Hz 0.15 mm displacement peak amplitude/60–500 Hz 2g).

Mounting position effect

There is no significant span effect due to mounting position. The zero effect can be eliminated by re-trimming output at zero after installation.

Sensor	Maximum zero shift
DP	±1.25 inH ₂ O (3,11 mbar)
AP and GP	±2.5 inH ₂ O (6,22 mbar)

Power supply effect

Digital output shift is less than ±0.005% of calibrated span per volt change in voltage at the transmitter terminals.

Transient protection (option T1)

Transient Protection option meets requirements of IEEE C62.41.2-2002, Location Category B.

Ring wave: 6 kV Crest, 100 kHz (0.5 μs)

Combination wave: 3 kA Crest (8/20 μs), 6 kV Crest (1.2/50 μs)

Electromagnetic compatibility (EMC)

Meets all industrial environment requirements of EN61326. Maximum deviation < 1percent span during EMC disturbance⁽¹⁾⁽²⁾.

- During surge event device may exceed maximum EMC deviation limit or reset; however, device will self-recover and return to normal operation within specified start-up time.
- Rosemount 4088 measurement type 1, 3, 5, 6 require shielded cable for the process temperature connection.

Functional specifications

Service

Liquid, gas, and vapor applications

Range and sensor limits

The range limits are shown in the tables below. The calibrated span must exceed the minimum trim span.

Table 10. Transmitter with Rosemount MultiVariable Sensor Module (Measurement Types 1 and 2)

Range	Differential pressure sensor ⁽¹⁾			
	Lower sensor limit (LSL)		Upper sensor limit (USL)	
1	-25 inH ₂ O (-62,16 mbar)		25 inH ₂ O (62,16 mbar)	
2	-250 inH ₂ O (-0,62 bar)		250 inH ₂ O (0,62 bar)	
3	-1000 inH ₂ O (-2,49 bar)		1000 inH ₂ O (2,49 bar)	
4	-150 psi (-10,34 bar)		150 psi (10,34 bar)	
5	-2000 psi (-137,89 bar)		2000 psi (137,89 bar)	
Extended range (code A) ⁽²⁾	-800 inH ₂ O (-1,99 bar)		800 inH ₂ O (1,99 bar)	
	Static pressure sensor			
	Absolute pressure		Gage pressure	
	LSL ⁽³⁾	USL	LSL ⁽⁴⁾	USL
6	0.5 psia (34,47 mbar)	300 psia (20,68 bar)	-14.2 psi (-0,98 bar)	300 psi (20,68 bar)
7		1500 psia (103,42 bar)		1500 psi (103,42 bar)
4		3626 psia (250,00 bar) ⁽⁵⁾		3626 psi (250,00 bar) ⁽⁵⁾
3 ⁽⁶⁾		800 psia (55,15 bar)		800 psi (55,15 bar)

1. The LSL for enhanced for flow performance class is 0 inH₂O (0 mbar).
2. For extended range (code A), the MSL is 250 inH₂O (0,62 bar).
3. Inert fill: Minimum gage pressure = -13.2 psi (0,91 bar); Minimum absolute pressure: 1.5 psia (103,42 mbar).
4. Assumes atmosphere pressure of 14.7 psia (1,0 bar).
5. For static pressure Range 4 with DP Range 1, the USL is 2000 psi (137,89bar).
6. Available with DP Range 1.

Table 11. Transmitter with Single Variable Coplanar Sensor Module (Measurement Types 3, 4, 5, and 7)

Range	DP sensor (measurement types 3 and 4)		GP sensor (measurement types 5 and 7)		AP sensor (measurement types 5 and 7)	
	LSL ⁽¹⁾	USL	LSL ⁽²⁾	USL	LSL	USL
0	N/A				0 psia (0 bar)	5 psia (0,34 bar)
1	-25 inH ₂ O (-62,16 mbar)	25 inH ₂ O (62,16 mbar)	-25 inH ₂ O (-62,16 mbar)	25 inH ₂ O (62,16 mbar)		30 psia (2,06 bar)
2						150 psia (10,34 bar)

Table 11. Transmitter with Single Variable Coplanar Sensor Module (Measurement Types 3, 4, 5, and 7)

Range	DP sensor (measurement types 3 and 4)		GP sensor (measurement types 5 and 7)		AP sensor (measurement types 5 and 7)	
	LSL ⁽¹⁾	USL	LSL ⁽²⁾	USL	LSL	USL
3	-1000 inH ₂ O (-2,49 bar)	1000 inH ₂ O (2,49 bar)	-393 inH ₂ O (-0,98 bar)	1000 inH ₂ O (2,49 bar)	0 psia (0 bar)	800 psia (55,15 bar)
4	-300 psi (-20,68 bar)	300 psi (20,68 bar)	-14.2 psi (-0,98 bar)	300 psi (20,68 bar)		4000 psia (275,79 bar)
5	-2000 psi (-137,89 bar)	2000 psi (137,89 bar)			2000 psi (137,89 bar)	N/A

1. The LSL is 0 inH₂O (0 mbar) for enhanced for flow performance class.
2. Assumes atmospheric pressure of 14.7 psia (1 bar).

Table 12. Transmitter with In-line Sensor Module (Measurement Types 6 and 8)

Range	Absolute pressure		Gage pressure	
	LSL	USL	LSL ⁽¹⁾	USL
1	0 psia (0 bar)	30 psia (2,06 bar)	-14.7 psi (-1,01 bar)	30 psi (2,06 bar)
2		150 psia (10,34 bar)		150 psi (10,34 bar)
3		800 psia (55,15 bar)		800 psi (55,15 bar)
4		4000 psia (275,79 bar)		4000 psi (275,79 bar)
5		10000 psia (689,47 bar)		10000 psi (689,47 bar)

1. Assumes an atmospheric pressure of 14.7 psi.

Table 13. Process Temperature RTD Interface (Measurement Types 1, 3, 5, and 6)⁽¹⁾

LSL	USL
-328 °F (-200 °C)	1562 °F (850 °C)

1. Transmitter is compatible with any Pt 100 RTD sensor. Examples of compatible RTDs include Rosemount Series 68 and 78 RTD Temperature Sensors.

Minimum span limits

Table 14. Transmitter with Rosemount MultiVariable Sensor Module (Measurement Types 1 and 2)

Range	Standard	Enhanced	Enhanced for flow
Differential pressure			
1	1.0 inH ₂ O (2,49 mbar)	0.50 inH ₂ O (1,24 mbar)	N/A
2	5.0 inH ₂ O (12,43 mbar)	2.5 inH ₂ O (6,22 mbar)	2.5 inH ₂ O (6,22 mbar)
3	20.0 inH ₂ O (49,73 mbar)	10.0 inH ₂ O (24,86 mbar)	10.0 inH ₂ O (24,86 mbar)
4	6.0 psi (0,41 bar)	3.0 psi (0,21 bar)	3.0 psi (0,21 bar)
5	40.0 psi (2,76 bar)	20.0 psi (1,38 bar)	N/A
Extended range (code A) ⁽¹⁾	N/A	25 inH ₂ O (62,16 mbar)	

Table 14. Transmitter with Rosemount MultiVariable Sensor Module (Measurement Types 1 and 2)

Range	Standard	Enhanced	Enhanced for flow
Static pressure range			
Allowable static pressure ranges for DP range 2–5, A			
4	145.00 psi (10,00 bar)	90.00 psi (6,21 bar)	90.00 psi (6,21 bar)
6	12.00 psi (0,83 bar)	7.50 psi (5,17 bar)	7.50 psi (5,17 bar)
7	60.00 psi (4,14 bar)	37.50 psi (2,59 bar)	37.50 psi (2,59 bar)
Allowable static pressure ranges for DP range 1			
3	32.00 psi (2,21 bar)	20.00 psi (1,38 bar)	N/A
4	145.00 psi (10,00 bar)	90.00 psi (6,21 bar)	

1. For extended range (code A), the MSL is 250 inH₂O (0,62 bar).

Table 15. Transmitter with Single Variable Coplanar Sensor Module (Measurement Types 3, 4, 5, and 7)

DP/GP range	Standard	Enhanced	Enhanced for Flow ⁽¹⁾
1	1.0 inH ₂ O (2,49 mbar)	0.5 inH ₂ O (1,24 mbar)	N/A
2	5.0 inH ₂ O (12,43 mbar)	2.5 inH ₂ O (6,22 mbar)	2.5 inH ₂ O (6,22 mbar)
3	20.0 inH ₂ O (49,73 mbar)	10.0 inH ₂ O (24,86 mbar)	5.0 inH ₂ O (12,43 mbar)
4	6.0 psi (0,41 bar)	3.0 psi (0,21 bar)	N/A
5	40.0 psi (2,76 bar)	20.0 psi (1,38 bar)	

1. Only available for differential pressure sensors (measurement types 3 and 4).

Table 16. Transmitter with Coplanar Absolute Pressure Sensor Module (Measurement Types 5 and 7)

AP range	Standard	Enhanced
0	0.3 psia (20,68 mbar)	0.3 psia (20,68 mbar)
1	0.6 psia (41,37 mbar)	0.3 psia (20,68 mbar)
2	3.0 psia (0,21 bar)	1.5 psia (0,10 bar)
3	16.0 psia (1,10 bar)	8.0 psia (0,55 bar)
4	80 psia (5,52 bar)	40 psia (2,76 bar)

Table 17. Transmitter with In-line Sensor Module (Measurement Types 6 and 8)

GP/AP range	Standard	Enhanced
1	0.6 psi (41,37 mbar)	0.3 psi (20,68 mbar)
2	3.0 psi (0,21 bar)	1.5 psi (0,10 bar)
3	16.0 psi (1,10 bar)	8.0 psi (0,55 bar)
4	80 psi (5,52 bar)	40 psi (2,76 bar)
5	4000 psi (275,79 bar)	2000 psi (137,89 bar)

Process temperature RTD interface

Minimum span = 50 °F (27.78 °C)

Digital communication protocol

The Rosemount 4088 MultiVariable Transmitter has multiple output protocols available. The Rosemount 4088A communicates via Modbus (RS-485) with 8 data bits, one stop bit, and no parity. Baud rates supported are 1200, 2400, 4800, 9600, and 19200.

The Rosemount 4088B communicates via MVS 205 and BSAP.

Both the Rosemount 4088A and 4088B have a HART port that is only available for configuration. This port conforms to the HART Revision 7 Specifications.

Power supply

External power supply required for Rosemount 4088

V _{min} (V)	V _{max} (V)
5.4	30

The maximum average current is I_{max} (mA) = 4.6 mA at 5.4 Vdc. This includes RS-485 communication at a rate of once per second and no HART communication.

Overpressure limits

Transmitter will withstand the following limits without damage.

Table 18. Transmitter with Rosemount MultiVariable Sensor Module (Measurement Types 1 and 2)

AP/GP range	Differential pressure range					
	1	2	3	4	5	A
3	1600 psi (110,32 bar)	N/A	N/A	N/A	N/A	N/A
4	2000 psi (137,89 bar)	3626 psi (250,00 bar)	3626 psi (250,00 bar)	3626 psi (250,00 bar)	3626 psi (250,00 bar)	
6	N/A	1600 psi (110,32 bar)		N/A	N/A	1600 psi (110,32 bar)
7		3626 psi (250,00 bar)				3626 psi (250,00 bar)

Table 19. Transmitter with Single Variable Sensor Module (Measurement Types 3, 4, 5, 6, 7, and 8)

Range	In-line style	Coplanar style		
		Absolute	Gage	DP
0	N/A	60 psia (4,14 bar)	N/A	N/A
1	750 psi (51,71 bar)	750 psia (51,71 bar)	2000 psi (137,89 bar)	2000 psi (137,89 bar)
2	1500 psi (103,42 bar)	1500 psia (103,42 bar)	3626 psi (250,00 bar)	3626 psi (250,00 bar)
3	1600 psi (110,32 bar)	1600 psia (110,32 bar)		
4	6000 psi (413,69 bar)	6000 psia (413,69 bar)		
5	15000 psi (1034,21 bar)	N/A		

Static pressure limits

Operates within specifications between static line pressures of 0.5 psia (0,03 bar) and the values in the tables below.

Table 20. Transmitter with Rosemount MultiVariable Sensor Module (Measurement Types 1 and 2)

DP Range	Static pressure range (GP/AP)			
	3	4	6	7
1	800 psi (55,15 bar)	2000 psi (137,89 bar)	N/A	N/A
2	N/A	3626 psi (250,00 bar)	300 psi (20,68 bar)	1500 psi (103,42 bar)
3				

Table 20. Transmitter with Rosemount MultiVariable Sensor Module (Measurement Types 1 and 2)

DP Range	Static pressure range (GP/AP)			
	3	4	6	7
4	N/A	3626 psi (250,00 bar)	N/A	N/A
5				
Extended range (code A)			N/A	300 psi (20,68 bar)

Table 21. Transmitter with Single Variable Coplanar Sensor Module (Measurement Types 3, 4, 5, and 7)

Range	DP sensor ⁽¹⁾
0	N/A
1	2000 psi (137,89 bar)
2	3626 psi (250,00 bar)
3	
4	
5	

1. The static pressure limit of a DP sensor with the P9 option is 4500 psi (310,30 bar). The static pressure limit of a DP sensor with the P0 option is 6092 psi (420,00 bar).

Burst pressure limits

Coplanar sensor module (measurement types 1, 2, 3, 4, 5, and 7)⁽¹⁾⁽²⁾

10000 psi (689,47 bar)

1. 12250 psi (844,61 bar) is the coplanar sensor module burst pressure limit with option code P9.
2. 16230 psi (1119,02 bar) is the coplanar sensor module burst pressure limit with option code P0.

In-line sensor module (measurement types 6 and 8)

Ranges 1–4: 11000 psi (758,42 bar)

Range 5: 26000 psi (1792,64 bar)

Maximum working pressure limits

Maximum working pressure is the maximum pressure allowed for normal transmitter operation. For a differential pressure transmitter, the maximum working pressure is the static line pressure under which the transmitter can safely operate. If one side of the transmitter is exposed to the full static line pressure due to mis-valving, the transmitter will experience an output shift and must be re-zeroed. For a gage or absolute pressure transmitter, the maximum working pressure is the same as the USL. The maximum working pressure of transmitters with assembled process connection options is limited by the lowest maximum pressure rating of the individual components.

Table 22. Transmitter with Multivariable Sensor Module (Measurement Types 1 and 2)

DP Range	Static pressure range (GP/AP)			
	3	4	6	7
1	800 psi (55,15 bar)	2000 psi (137,89 bar)	N/A	N/A
2	N/A	3626 psi (250,00 bar)	300 psi (20,68 bar)	1500 psi (103,42 bar)
3				
4				
5			N/A	N/A
Extended range (code A)			N/A	300 psi (20,68 bar)

Table 23. Transmitter with Single Variable Sensor Module (Measurement Types 3, 4, 5, 6, 7, and 8)

Range	Coplanar (measurement types 3 and 4)			In-line (measurement types 6 and 8)	
	Differential pressure ⁽¹⁾	Gage pressure	Absolute pressure	Gage pressure	Absolute pressure
0	N/A	N/A	5 psia (0,35 bar)	N/A	N/A
1	2000 psi (137,89 bar)	0.9 psi (0,06 bar)	30 psia (2,06 bar)	30 psi (2,06 bar)	30 psia (2,06 bar)
2	3626 psi (250,00 bar)	9 psi (0,62 bar)	150 psia (10,34 bar)	150 psi (10,34 bar)	150 psia (10,34 bar)
3		36 psi (2,48 bar)	800 psia (55,15 bar)	800 psi (55,15 bar)	800 psia (55,15 bar)
4		300 psi (20,68 bar)	4000 psia (275,79 bar)	4000 psi (275,79 bar)	4000 psia (275,79 bar)
5		2000 psi (137,89 bar)	N/A	10000 psi (689,47 bar)	10000 psia (689,47 bar)

1. The maximum working pressure limit of a DP Sensor with the P9 option is 4500 psi (310,30 bar). The maximum working pressure limit of a DP Sensor with the P0 option is 6092 psi (420,00 bar).

Temperature limits

Ambient

–40 to 185 °F (–40 to 85 °C)
 with LCD display⁽¹⁾: –40 to 176 °F (–40 to 80 °C)
 with option code P0: –20 to 185 °F (–29 to 85 °C)

1. LCD display may not be readable and LCD display updates will be slower at temperatures below –4 °F (–20 °C).

- 3. 220 °F (104 °C) limit in vacuum service; 130 °F (54 °C) for pressures below 0.5 psia.
- 4. –20 °F (–29 °C) is the lower process temperature limit with option code P0.
- 5. 32 °F (0 °C) is the lower process temperature limit for DP Range 0.
- 6. For measurement types 3, 4, 5, and 7 there is a 160 °F (71 °C) limit in vacuum service. For measurement types 1 and 2 there is a 140 °F (60 °C) limit in vacuum service.
- 7. Not available measurement types 5 and 7 with an absolute static pressure sensor.

Storage

–50 to 185 °F (–46 to 85 °C)
 with LCD display: –40 to 185 °F (–40 to 85 °C)

Process temperature limits

At atmospheric pressures and above:

Coplanar sensor module (measurement types 1, 2, 3, 4, 5, and 7)	
Silicone fill sensor ⁽¹⁾⁽²⁾	
with coplanar flange	–40 to 250 °F (–40 to 121 °C) ⁽³⁾
with traditional flange	–40 to 300 °F (–40 to 149 °C) ⁽³⁾⁽⁴⁾
with level flange	–40 to 300 °F (–40 to 149 °C) ⁽³⁾
with Rosemount 305 Integral Manifold	–40 to 300 °F (–40 to 149 °C) ⁽³⁾⁽⁴⁾
Inert fill sensor ⁽¹⁾⁽⁵⁾	–40 to 185 °F (–40 to 85 °C) ⁽⁶⁾⁽⁷⁾
In-line sensor module (measurement types 6 and 8)	
Silicone fill sensor ⁽¹⁾	–40 to 250 °F (–40 to 121 °C) ⁽³⁾
Inert fill sensor ⁽¹⁾	–22 to 250 °F (–30 to 121 °C) ⁽³⁾

- 1. Process temperatures above 185 °F (85 °C) require derating the ambient limits by a 1.5:1 ratio. For example, for process temperature of 195 °F (91 °C), new ambient temperature limit is equal to 170 °F (77 °C). This can be determined as follows: (195 – 185 °F) x 1.5 = 15 °F, 185 – 15 °F = 170 °F
- 2. 212 °F (100 °C) is the upper process temperature limit for DP Range 0.

Humidity limits

0 to 100 percent relative humidity

Turn-on time

Transmitter performance will be within specifications within five seconds of power being applied.

Volumetric displacement

Less than 0.005 in³ (0,08 cm³)

Damping

Output response time to a step change is user-selectable from 0 to 60 seconds for one time constant. Each measured variable (Differential Pressure, Static Pressure, and Process Temperature) can be individually adjusted. Software damping is in addition to sensor module response time.

Physical specifications

Material selection

Emerson provides a variety of Rosemount products with various product options and configurations including materials of construction that can be expected to perform well in a wide range of applications. The Rosemount product information presented is intended as a guide for the purchaser to make an appropriate selection for the application. It is the purchaser's sole responsibility to make a careful analysis of all process parameters (such as all chemical components, temperature, pressure, flow rate, abrasives, contaminants, etc.), when specifying product materials, options, and components for the particular application. Emerson is not in a position to evaluate or guarantee the compatibility of the process fluid or other process parameters with the product, options, configuration or materials of construction selected.

Electrical connections

1/2–14 NPT and M20 x 1.5 conduit; Modbus or BSAP/MVS interface connections fixed to terminal block

Process connections

Coplanar sensor module (measurement types 1, 2, 3, 4, 5, and 7)	
Standard	1/4–18 NPT on 2 1/8-in. centers
Flange adapters	1/2–14 NPT on 2-in. (50.8 mm), 2 1/8-in. (54.0 mm), or 2 1/4-in. (57.2 mm) centers
In-line sensor module (measurement types 6 and 8)	
Standard	1/2–14 NPT female

Process-wetted parts

Process isolating diaphragms

Coplanar sensor module (measurement types 1, 2, 3, 4, 5, and 7)
316L SST (UNS S31603), Alloy C-276 (UNS N10276), Alloy 400 (UNS N04400)
In-line sensor module (measurement types 6 and 8)
316L SST (UNS S31603), Alloy C-276 (UNS N10276)

Drain/vent valves

316 SST or Alloy C-276 material

Process flanges and flange adapters

Plated CS
SST: CF-8M (Cast 316 SST) per ASTM A743
Cast C-276: CW-12MW per ASTM A494

Wetted O-rings

Glass-filled PTFE

Non-wetted parts

Electronics housing

Low-copper aluminum alloy or CF-8M (Cast 316 SST)

Enclosures meet NEMA® Type 4X, IP66, and IP68 [66 ft. (20 m) for 168 hours] when properly installed.

Sensor module housing

SST: CF-3M (cast 316L SST)

Bolts

Plated CS per ASTM A449, Type 1
Austenitic 316 SST per ASTM F593
ASTM A453, Class D, Grade 660 SST
ASTM A193, Grade B7M alloy steel
ASTM A193, Class 2, Grade B8M SST
Alloy K-500

Sensor module fill fluid

Silicone or inert halocarbon (inert not available with coplanar absolute pressure sensors). Inert for in-line series uses Fluorinert® FC-43.

Paint for aluminum housing

Polyurethane

Cover O-rings

Buna-N

Shipping weights

Sensor module weights⁽¹⁾

Coplanar sensor module	In-line sensor module
3.1 lb (1,4 kg)	1.4 lb (0,6 kg)

1. Flange and bolts not included.

Transmitter weights⁽¹⁾

Transmitter with coplanar sensor module (measurement types 1, 2, 3, 4, 5, and 7)	
Aluminum housing, SST flange	5.39 lb (2,44 kg)
Transmitter with in-line sensor module (measurement types 6 and 8)	
Aluminum housing	3.65 lb (1,66 kg)

1. Fully functional transmitter with sensor module, housing, terminal block, and covers. Does not include LCD display.

Transmitter option weights

Option code	Option	Add lb (kg)
1J, 1K	SST housing	1.9 (1,1)
M5 ⁽¹⁾	LCD display for aluminum housing LCD display for sst housing	0.3 (0,1) 0.2 (0,1)
B4	SST mounting bracket for coplanar flange	1.2 (0,5)
B1, B7	Mounting bracket for traditional flange	1.7 (0,8)
B2, B8	Mounting bracket for traditional flange with SST bolts	1.3 (0,6)
B3, B9	Flat mounting bracket for traditional flange	1.7 (0,8)
BA, BC	SST bracket for traditional flange	1.6 (0,7)
B4	SST mounting bracket for in-line configuration	1.3 (0,6)
F12 ⁽²⁾	SST traditional flange with SST drain vents	3.2 (1,5)
F13 ⁽²⁾	Cast C-276 traditional flange with Alloy C-276 drain vents	3.6 (1,6)
E12 ⁽²⁾	SST coplanar flange with SST drain vents	1.9 (0,9)
F15 ⁽²⁾	SST traditional flange with Alloy C-276 drain vents	3.2 (1,5)

1. Includes LCD display and display cover.

2. Includes mounting bolts.

Transmitter component weights

Item	Weight in lb (kg)
Aluminum standard cover	0.4 (0,2)
SST standard cover	1.3 (0,6)
Aluminum display cover	0.7 (0,3)
SST display cover	1.5 (0,7)
LCD display ⁽¹⁾	0.1 (0,04)
Terminal block	0.2 (0,1)

1. Display only.

Product Certifications

Rev 1.6

⚠ WARNING

Explosions could result in death or serious injury.

Installation of this transmitter in an explosive environment must be in accordance with the appropriate local, national, and international standards, codes, and practices. Review this document for any restrictions associated with a safe installation.

- Before connecting a Field Communicator in an explosive atmosphere, ensure the instruments in the loop are installed in accordance with intrinsically safe or non-incendive field wiring practices.
- In an Explosion-proof/Flameproof installation, do not remove the transmitter covers when power is applied to the unit.

Conduit/cable entries

- Unless marked, the conduit/cable entries in the transmitter housing use a 1/2–14 NPT thread form. Entries marked “M20” are M20 x 1.5 thread form. On devices with multiple conduit entries, all entries will have the same thread form. Only use plugs, adapters, glands, or conduit with a compatible thread form when closing these entries.
- When installing in a hazardous location, use only appropriately listed or Ex certified plugs, adapters, or glands in cable/conduit entries.

European Directive Information

A copy of the EU Declaration of Conformity can be found at the end of the Quick Start Guide. The most recent revision of the EU Declaration of Conformity can be found at Emerson.com/Rosemount.

Markings: XP Class I, Division 1, Groups B, C, D
($T_a = -50$ to 85 °C); DIP Class II and Class III,
Division 1, Groups E, F, G ($T_a = -50$ to 85 °C);
Class I Zone 0/1 AEx db IIC T5
($T_a = -50$ to 80 °C); Enclosure Type
4X/IP66/IP68; Conduit seal not required for
division installations

Ordinary Location Certification

As standard, the transmitter has been examined and tested to determine that the design meets the basic electrical, mechanical, and fire protection requirements by a nationally recognized test laboratory (NRTL) as accredited by the Federal Occupational Safety and Health Administration (OSHA).

Installing Equipment in North America

The US National Electrical Code® (NEC) and the Canadian Electrical Code (CEC) permit the use of Division marked equipment in Zones and Zone marked equipment in Divisions. The markings must be suitable for the area classification, gas, and temperature class. This information is clearly defined in the respective codes.

USA

E5 FM Explosionproof (XP), Dust-Ignitionproof (DIP)

Certificate: FM17US0146X

Standards: FM Class 3600 - 2011, FM 3610 - 2005,
FM Class 3615 - 2005, FM Class 3616 2011,
FM 3810 - 2005, ANSI/NEMA 250 - 1991,
ANSI/IEC 60529 - 2004,
ANSI/ISA 60079-0:2013,
ANSI/ISA 60079-1:2015,
ANSI/ISA 60079-26:2017

Special Conditions for Safe Use (X):

1. This device contains a thin wall diaphragm less than 1 mm thickness that forms a boundary between Class 1, Zone 0 (process connection) and Class 1, Zone 1 (all other parts of the equipment). The model code and datasheet are to be consulted for details of the diaphragm material. Installation, maintenance and use shall take into account the environmental conditions to which the diaphragm will be subjected. The manufacturer's instructions for installation and maintenance shall be followed in detail to assure safety during its expected lifetime.
2. Flameproof joints are not intended for repair.
3. Appropriate cable, glands, and plugs need to be suitable for a temperature of 5 °C greater than the maximum specified temperature for location where installed.
4. The applicable temperature class, ambient temperature range and process temperature range of the equipment is T4 for $-50 \leq T_a \leq 80$ °C with T process = -50 to 120 °C.
5. Non-standard paint options (paint options other than Rosemount Blue) may cause risk from electrostatic discharge. Avoid installation that could cause electrostatic build-up on painted surfaces, and only clean the painted surfaces with a damp cloth.
6. Display glass shall be positioned in such a way as to minimize the risk of mechanical impact.

- I5** FM Intrinsic Safety (IS) and Nonincendive (NI)
 Certificate: FM17US0263X
 Standards: FM Class 3600 - 2011, FM Class 3610 - 2010, FM Class 3611 - 2004, FM Class 3810 - 2005, ANSI/NEMA 250 - 1991, ANSI/ISA 60529 - 2004, ANSI/ISA 61010-1 - 2004
 Markings: Intrinsic Safety Class I, Division 1, Groups C, D; Class II, Groups E, F, G; Class III; Class I Zone 0 AEx ia IIB T4; Nonincendive Class I, Division 2, Groups A, B, C, D; T4(-50 ≤ T_a ≤ 70 °C); when connected per Rosemount drawing 04088-1206; Type 4X

Special Conditions for Safe Use (X):

1. The maximum permitted ambient temperature of the Rosemount 4088 Pressure Transmitter is 70 °C. To avoid the effects of process temperature and other thermal effects care shall be taken to ensure the surrounding ambient and the ambient inside the transmitter housing does not exceed 70 °C.
2. The enclosure may contain aluminum and is considered to present a potential risk of ignition by impact or friction. Care must be taken during installation and use to prevent impact or friction.
3. The Rosemount 4088 Transmitters fitted with transient protection are not capable of withstanding the 500 V test. This must be taken into account during installation.

Note

Transmitters marked with NI CL 1, DIV 2 can be installed in Division 2 locations using general Division 2 wiring methods or Nonincendive Field Wiring (NIFW). See Drawing 04088-1206.

Canada

All CSA hazardous approved transmitters are dual seal certified per ANSI/ISA 12.27.01-2003.

- E6** CSA Explosionproof, Dust-Ignitionproof, and Division 2
 Certificate: 2618446
 Standards: CSA C22.2 No. 0-10, CSA C22.2 No. 25-1966, CSA C22.2 No. 30-M1986, CSA C22.2 No. 94-M91, CSA C22.2 No. 142-M1987, CSA C22.2 No. 213-M1987, CSA C22.2 No. 60079-0:2011, CSA C22.2 No. 60079-11:2011, ANSI/ISA 12.27.01-2003
 Markings: Class I, Division 1, Groups B, C, D; Class II, Division 1, Groups E, F, G; Class III; Class I, Division 2, Groups A, B, C, D; Temp Code T5; seal not required; when installed per Rosemount Drawing 04088-1053; Type 4X

- I6** CSA Intrinsically Safe
 Certificate: 2618446
 Standards: CSA C22.2 No. 0-10, CSA C22.2 No. 25-1966, CSA C22.2 No. 30-M1986, CSA C22.2 No. 94-M91, CSA C22.2 No. 142-M1987, CSA C22.2 No. 157-92, CSA C22.2 No. 213-M1987, CSA C22.2 No. 60079-0:2011, CSA C22.2 No. 60079-11:2011, ANSI/ISA 12.27.01-2003
 Markings: Class I, Division 1, Groups C, D, Temp Code T3C; Class I Zone 0 Ex ia IIB T4; when installed per Rosemount Drawing 04088-1207; Type 4X

Europe

- E1** ATEX Flameproof
 Certificate: FM12ATEX0030X
 Standards: EN 60079-0:2012+A11:2013, EN 60079-1:2014, EN 60079-26:2015, EN 60529:1991+A1:2000
 Markings: Ⓔ II 1/2 G Ex db IIC T6...T4 Ga/Gb, T4/T5(-50 ≤ T_a ≤ 80 °C), T6(-50 ≤ T_a ≤ 65 °C)

Special Conditions for Safe Use (X):

1. This device contains a thin wall diaphragm less than 1 mm thickness that forms a boundary between Category 1 (process connection) and Category 2 (all other parts of the equipment). The model code and datasheet are to be consulted for details of the diaphragm material. Installation, maintenance and use shall take into account the environmental conditions to which the diaphragm will be subjected. The manufacturer's instructions for installation and maintenance shall be followed in detail to assure safety during its expected lifetime.
2. Flameproof joints are not intended for repair.
3. Appropriate cable, glands, and plugs need to be suitable for a temperature of 5 °C greater than the maximum specified temperature for location where installed.
4. The applicable temperature class, ambient temperature range and process temperature range of the equipment is as follows:
 - T4 for -50 ≤ T_a ≤ 80 °C with T process = -50 to 120 °C
 - T5 for -50 ≤ T_a ≤ 80 °C with T process = -50 to 80 °C
 - T6 for -50 ≤ T_a ≤ 65 °C with T process = -50 to 65 °C
5. Non-standard paint options (paint options other than Rosemount Blue) may cause risk from Electrostatic discharge. Avoid installation that could cause electrostatic build-up on painted surfaces, and only clean the painted surfaces with a damp cloth.
6. Display glass shall be positioned in such a way as to minimize the risk of mechanical impact.

I1 ATEX Flameproof

Certificate: Baseefa13ATEX0221X

Standards: EN 60079-0:2012, EN 60079-11:2012

Markings: Ex II 1 G Ex ia IIB T4 Ga ($-60 \leq T_a \leq +70$ °C)

	Supply	Modbus	RTD
Voltage U_i	22 V	9 V	15.51 V
Current I_i	147 mA	26 mA	20.89 mA
Power P_i	1 W	1 W	80.94 mW
Capacitance C_i	0	0	0
Inductance L_i	0	0	0

Special Conditions for Safe Use (X):

1. The Rosemount 4088 MV Transmitters fitted with transient protection are not capable of withstanding the 500 V test as defined in Clause 6.3.13 of EN 60079-11:2012. This must be taken into account during installation.
2. The Rosemount 4088 MV enclosure may be made of aluminum alloy and given a protective polyurethane paint finish; however, care should be taken to protect it from impact or abrasion if located in a Zone 0 area.

ND ATEX Dust

Certificate: FM12ATEX0030X

Standards: EN 60079-0:2012+A11:2013,
EN 60079-31:2014, EN 60529:1991+A1:2000Markings: Ex II 2 D Ex tb IIIC T95 °C, $T_a = -20$ to 85 °C Db**Special Conditions for Safe Use (X):**

1. Cable entries must be used which maintain the ingress protection of the enclosure to at least IP66/68.
2. Unused cable entries must be filled with suitable blanking plugs which maintain the ingress protection of the enclosure to at least IP66/68.
3. Cable entries and blanking plugs must be suitable for the ambient range of the apparatus and capable of withstanding a 7J impact test.
4. Non-standard paint options (paint options other than Rosemount Blue) may cause risk from Electrostatic discharge. Avoid installation that could cause electrostatic build-up on painted surfaces, and only clean the painted surfaces with a damp cloth.
5. Display glass shall be positioned in such a way as to minimize the risk of mechanical impact.

N1 ATEX Type n

Certificate: Baseefa13ATEX0222X

Standards: EN 60079-0:2012, EN 60079-15: 2010

Markings: Ex II 3 G Ex nA IIC T5 Gc ($-40 \leq T_a \leq 70$ °C)**Special Condition for Safe Use (X):**

1. The Rosemount 4088 MV Transmitters fitted with transient protection are not capable of withstanding the 500 V test as defined in Clause 6.5.1 of EN 60079-15:2010. This must be taken into account during installation.

International**E7** IECEx Flameproof

Certificate: IECEx FMG 13.0024X

Standards: IEC 60079-0:2011, IEC 60079-1: 2014,
IEC 60079-26: 2014Markings: Ex db IIC T6...T4 Ga/Gb, T4/T5 ($-50 \leq T_a \leq 80$ °C),
T6 ($-50 \leq T_a \leq 65$ °C)**Special Conditions for Safe Use (X):**

1. This device contains a thin wall diaphragm less than 1 mm thickness that forms a boundary between EPL Ga (process connection) and EPL Gb (all other parts of the equipment). The model code and datasheet are to be consulted for details of the diaphragm material. Installation, maintenance and use shall take into account the environmental conditions to which the diaphragm will be subjected. The manufacturer's instructions for installation and maintenance shall be followed in detail to assure safety during its expected lifetime.
2. Flameproof joints are not intended for repair.
3. Appropriate cable, glands, and plugs need to be suitable for a temperature of 5 °C greater than the maximum specified temperature for location where installed.
4. The applicable temperature class, ambient temperature range and process temperature range of the equipment is as follows:
 - T4 for $-50 \leq T_a \leq 80$ °C with T process = -50 to 120 °C
 - T5 for $-50 \leq T_a \leq 80$ °C with T process = -50 to 80 °C
 - T6 for $-50 \leq T_a \leq 65$ °C with T process = -50 to 65 °C
5. Non-standard paint options (paint options other than Rosemount Blue) may cause risk from Electrostatic discharge. Avoid installation that could cause electrostatic build-up on painted surfaces, and only clean the painted surfaces with a damp cloth.
6. Display glass shall be positioned in such a way as to minimize the risk of mechanical impact.

I7 IECEx Intrinsic Safety

Certificate: IECEx BAS 13.0110X

Standards: IEC 60079-0:2011, IEC 60079-11:2011

Markings: Ex ia IIB T4 Ga ($-60 \leq T_a \leq +70$ °C)

	Supply	Modbus	RTD
Voltage U_i	22 V	9 V	15.51 V
Current I_i	147 mA	26 mA	20.89 mA
Power P_i	1 W	1 W	80.94 mW
Capacitance C_i	0	0	0
Inductance L_i	0	0	0

Special Conditions for Safe Use (X):

1. The Rosemount 4088 MV Transmitters fitted with transient protection are not capable of withstanding the 500V test as defined in Clause 6.3.13 of IEC 60079-11:2012. This must be taken into account during installation.
2. The Rosemount 4088 MV enclosure may be made of aluminum alloy and given a protective polyurethane paint finish; however, care should be taken to protect it from impact or abrasion if located in a Zone 0 area.

NK IECEx Dust

Certificate: IECEx FMG 13.0024X

Standards: IEC 60079-0:2011, IEC 60079-31:2013

Markings: Ex tb IIIC T95 °C, $T_a = -20$ to 85 °C, Db**Special Conditions of Use (X):**

1. Cable entries must be used which maintain the ingress protection of the enclosure to at least IP66/68.
2. Unused cable entries must be filled with suitable blanking plugs which maintain the ingress protection of the enclosure to at least IP66/68.
3. Cable entries and blanking plugs must be suitable for the ambient range of the apparatus and capable of withstanding a 7J impact test.
4. Non-standard paint options (paint options other than Rosemount Blue) may cause risk from Electrostatic discharge. Avoid installation that could cause electrostatic build-up on painted surfaces, and only clean the painted surfaces with a damp cloth.
5. Display glass shall be positioned in such a way as to minimize the risk of mechanical impact.

N7 IECEx Type n

Certificate: IECEx BAS 13.0111X

Standards: IEC 60079-0:2011, IEC 60079-15: 2010

Markings: Ex nA IIC T5 Gc ($-40 \leq T_a \leq +70$ °C)**Special Condition for Safe Use (X):**

1. The Rosemount 4088 MV Transmitters fitted with transient protection are not capable of withstanding the 500 V test as defined in Clause 6.5.1 of IEC 60079-15:2010. This must be taken into account during installation.

Brazil**E2** INMETRO Flameproof

Certificate: UL-BR 15.0531X

Standards: ABNT NBR IEC60079-0:2013,
ABNT NBR IEC60079-1:2016,
ABNT NBR IEC60079-26:2016Markings: Ex db IIC T6...T4 Ga/Cb, T6($-50 \leq T_a \leq +65$ °C),
T5/T4($-50 \leq T_a \leq +80$ °C)**Special Conditions for Safe Use (X):**

1. This device contains a thin wall diaphragm. Installation, maintenance and use shall take into account the environmental conditions to which the diaphragm will be subjected. The manufacturer's instructions for installation and maintenance shall be followed in detail to assure safety during its expected lifetime.
2. Flameproof joints are not intended for repair.
3. Appropriate cable, glands, and plugs need to be suitable for a temperature of 5 °C greater than the maximum specified temperature for the location where it is installed.
4. Non-standard paint options (paint options other than Rosemount Blue) may cause risk from electrostatic discharge. Avoid installation that could cause electrostatic build-up on painted surfaces, and only clean the painted surfaces with a damp cloth.
5. Display Glass should be positioned in such a way as to minimize the risk of mechanical impact.
6. The applicable temperature class, ambient temperature range and process temperature range of the equipment is as follows:
 - T4 for $-50 \leq T_a \leq 80$ °C with T process = -50 to 120 °C
 - T5 for $-50 \leq T_a \leq 80$ °C with T process = -50 to 80 °C
 - T6 for $-50 \leq T_a \leq 65$ °C with T process = -50 to 65 °C

I2 INMETRO Intrinsic Safety

Certificate: UL-BR 15.0720X

Standards: ABNT NBR IEC60079-0:2008 + Errata 1:2011,
ABNT NBR IEC60079-11:2009Markings: Ex ia IIB T4 Ga, T4($-60 \leq T_a \leq +70$ °C)

	Supply	Modbus	RTD
Voltage U_i	22 V	9 V	15.51 V
Current I_i	147 mA	26 mA	20.89 mA
Power P_i	1 W	1 W	80.94 mW
Capacitance C_i	0	0	0
Inductance L_i	0	0	0

Special Conditions for Safe Use (X):

1. If the equipment is fitted with an optional 90V transient suppressor, it is not capable of withstanding the 500 V insulation test required by ABNT NBR IRC 60079-11. This must be taken into account when installing the equipment.
2. The enclosure may be made of aluminum alloy and given a protective polyurethane paint finish; however, care should be taken to protect it from impact or abrasion in zones that require EPL Ga.

Technical Regulations Customs Union (EAC)

EM EAC Flameproof

Certificate: RU C-US.M1062.B.02349

Markings: Ga/Gb Ex d IIC T6...T4 X, T5/T4(-50 ≤ T_a ≤ +80 °C), T6(-50 ≤ T_a ≤ +65 °C)

Special Condition for Safe Use (X):

1. See certificate for special conditions.

IM EAC Intrinsically Safe

Certificate: RU C-US.M1062.B.02349

Markings: 0Ex ia IIB T4 Ga X, T4(-60 ≤ T_a ≤ +70 °C)

Special Condition for Safe Use (X):

1. See certificate for special conditions.

Combinations

- K1** Combination of E1, I1, N1, and ND
- K2** Combination of E2 and I2
- K5** Combination of E5 and I5
- K6** Combination of E6 and I6
- K7** Combination of E7, I7, N7, and NK
- KA** Combination of E1, I1, E6, and I6
- KB** Combination of E5, I5, E6, and I6
- KC** Combination of E1, I1, E5, and I5
- KD** Combination of E1, I1, E5, I5, E6, and I6
- KM** Combination of EM and IM

Dimensional drawings

Process adapters (option D2) and Rosemount 305 Integral Manifolds must be ordered with the transmitter.

Figure 1. Transmitter with Coplanar Sensor Module and Coplanar Flange

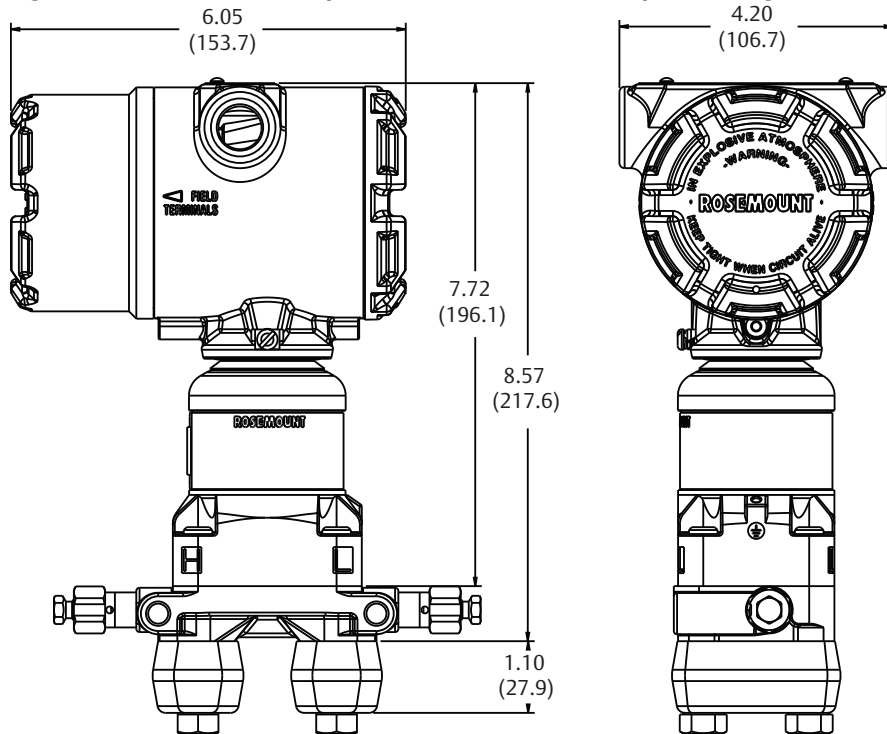

Dimensions are in inches (millimeters).

Figure 2. Transmitter with Coplanar Sensor Module and Traditional Flange

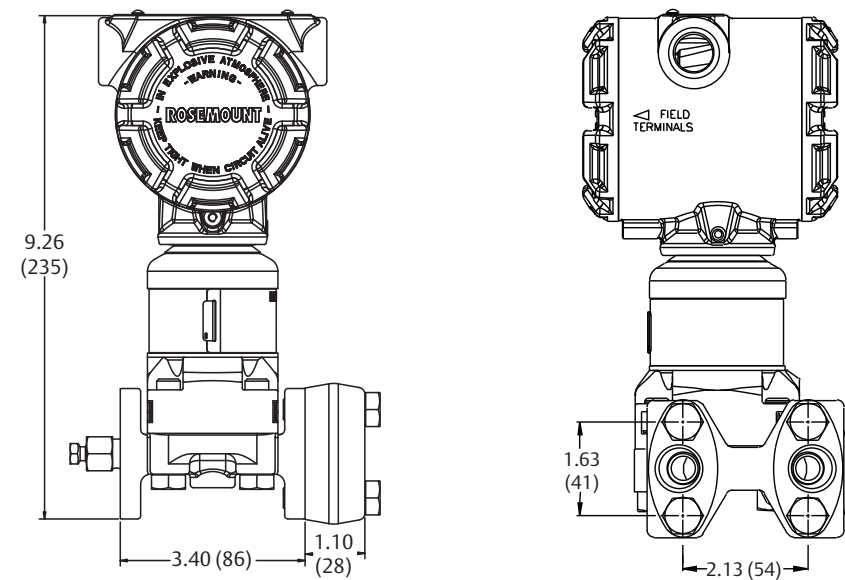

Dimensions are in inches (millimeters).

Figure 3. Transmitter with In-line Sensor Module

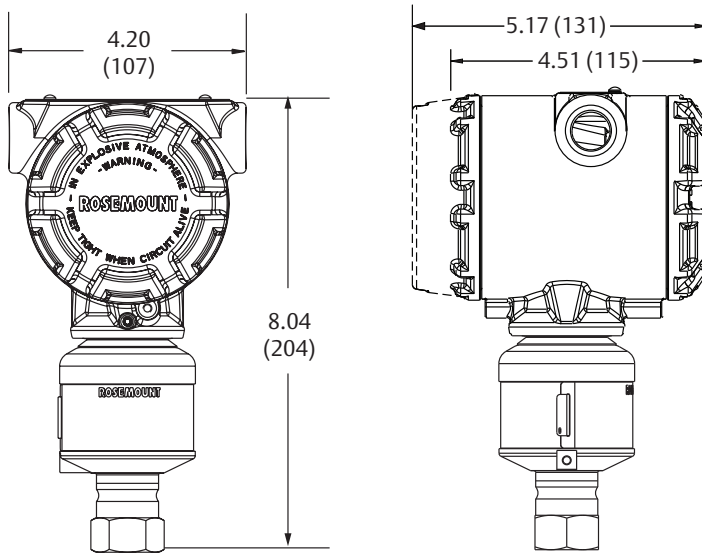

Dimensions are in inches (millimeters).

Figure 4. Coplanar Flange Mounting Configurations

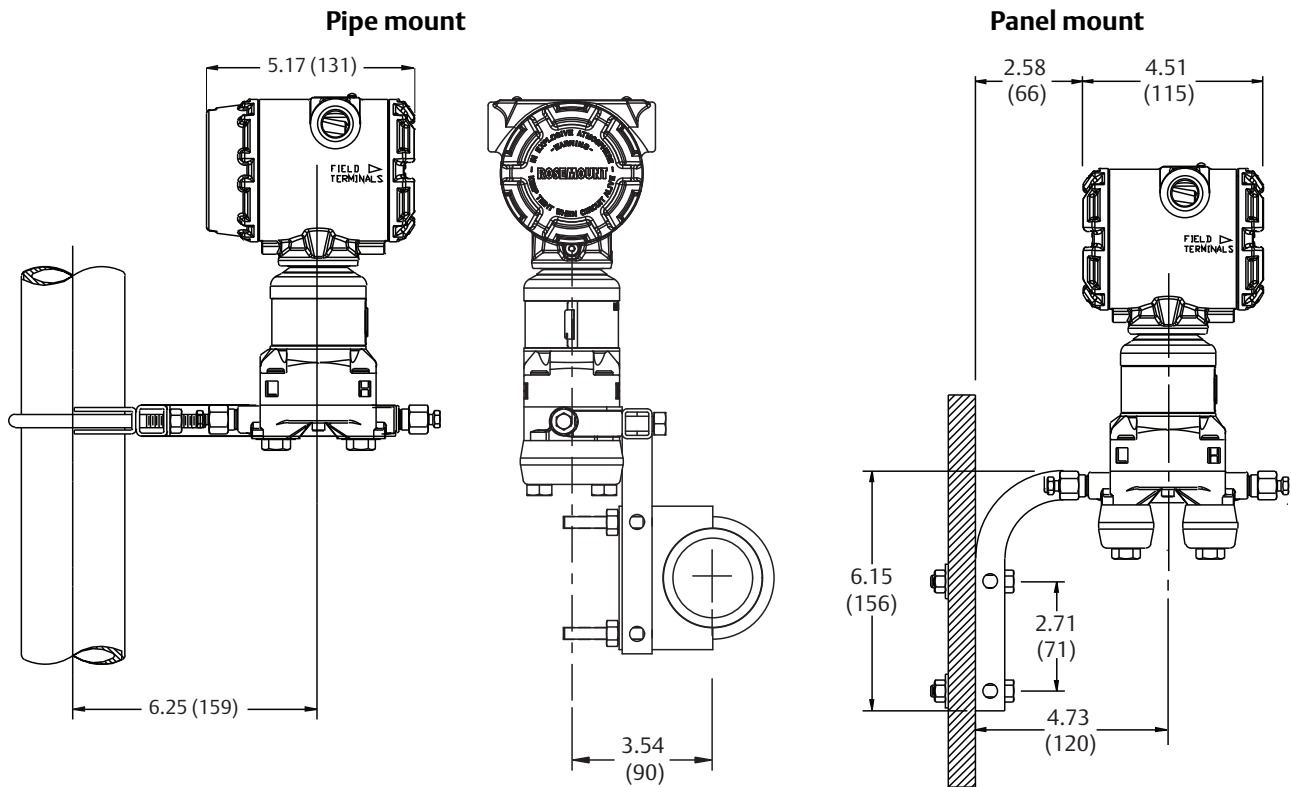

Dimensions are in inches (millimeters).

Figure 5. Traditional Flange Mounting Configurations

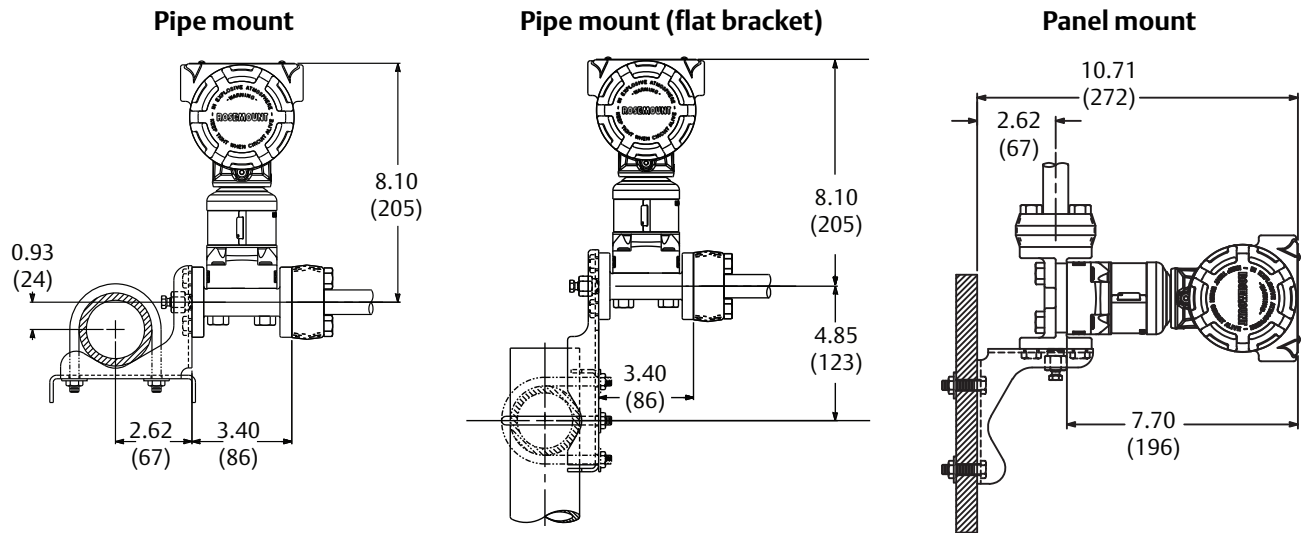

Dimensions are in inches (millimeters).

Figure 6. In-Line Mounting Configurations

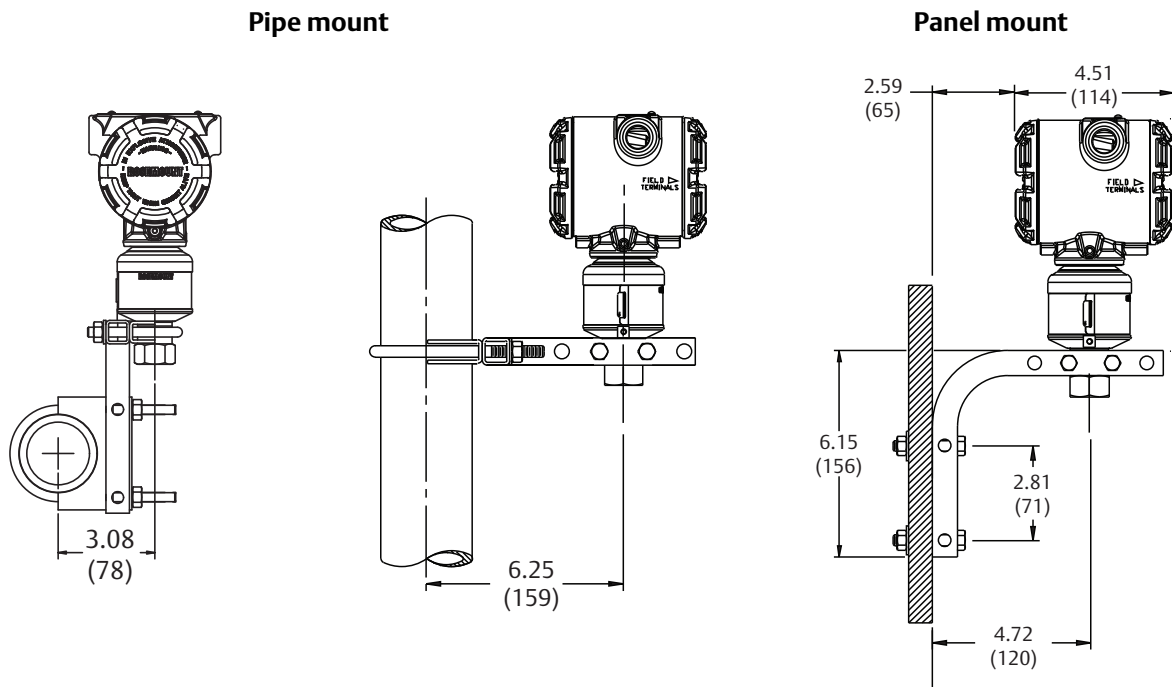













Dimensions are in inches (millimeters).



HIGH ACCURACY

measurement instruments

Our offering:

	<p>Pressure Measurement</p>		<p>Level Measurement</p>
	<p>Temperature Measurement</p>		<p>Flow Measurement</p>
	<p>Marine Measurement & Analytical</p>		<p>Gas Analysis</p>
	<p>Liquid Analysis</p>		<p>Flame and Gas Detection</p>
	<p>Tank Gauging</p>		<p>Wireless Infrastructure</p>
	<p>Acoustic & Discrete</p>		

www.high-accuracy.com

Global Headquarters

Emerson Automation Solutions

6021 Innovation Blvd.
Shakopee, MN 55379, USA
+1 800 999 9307 or +1 952 906 8888
+1 952 949 7001
RFQ.RMD-RCC@Emerson.com

North America Regional Office

Emerson Automation Solutions

8200 Market Blvd.
Chanhassen, MN 55317, USA
+1 800 999 9307 or +1 952 906 8888
+1 952 949 7001
RMT-NA.RCCRFQ@Emerson.com

Latin America Regional Office

Emerson Automation Solutions

1300 Concord Terrace, Suite 400
Sunrise, FL 33323, USA
+1 954 846 5030
+1 954 846 5121
RFQ.RMD-RCC@Emerson.com

Europe Regional Office

Emerson Automation Solutions Europe GmbH

Neuhofstrasse 19a P.O. Box 1046
CH 6340 Baar
Switzerland
+41 (0) 41 768 6111
+41 (0) 41 768 6300
RFQ.RMD-RCC@Emerson.com

Asia Pacific Regional Office

Emerson Automation Solutions

1 Pandan Crescent
Singapore 128461
+65 6777 8211
+65 6777 0947
Enquiries@AP.Emerson.com

Middle East and Africa Regional Office

Emerson Automation Solutions

Emerson FZE P.O. Box 17033
Jebel Ali Free Zone - South 2
Dubai, United Arab Emirates
+971 4 8118100
+971 4 8865465
RFQ.RMTMEA@Emerson.com

 [Linkedin.com/company/Emerson-Automation-Solutions](https://www.linkedin.com/company/Emerson-Automation-Solutions)

 [Twitter.com/Rosemount_News](https://twitter.com/Rosemount_News)

 [Facebook.com/Rosemount](https://www.facebook.com/Rosemount)

 [Youtube.com/user/RosemountMeasurement](https://www.youtube.com/user/RosemountMeasurement)

 [Google.com/+RosemountMeasurement](https://www.google.com/+RosemountMeasurement)

Standard Terms and Conditions of Sale can be found on the [Terms and Conditions of Sale page](#).

The Emerson logo is a trademark and service mark of Emerson Electric Co.

Annubar, Coplanar, MultiVariable, Rosemount and Rosemount logotype are trademarks of Emerson.

Bristol is a trademark of Remote Automation Solutions, a subsidiary of Emerson.

HART is a registered trademark of the FieldComm Group.

Modbus is a registered trademark of Gould Inc.

NACE is a registered trademark of NACE International.

National Electrical Code is a registered trademark of National Fire Protection Association, Inc.

NEMA is a registered trademark and service mark of the National Electrical Manufacturers Association.

Fluorinert is a trademark of 3M.

All other marks are the property of their respective owners.

© 2018 Emerson. All rights reserved.