



**HIGH ACCURACY**

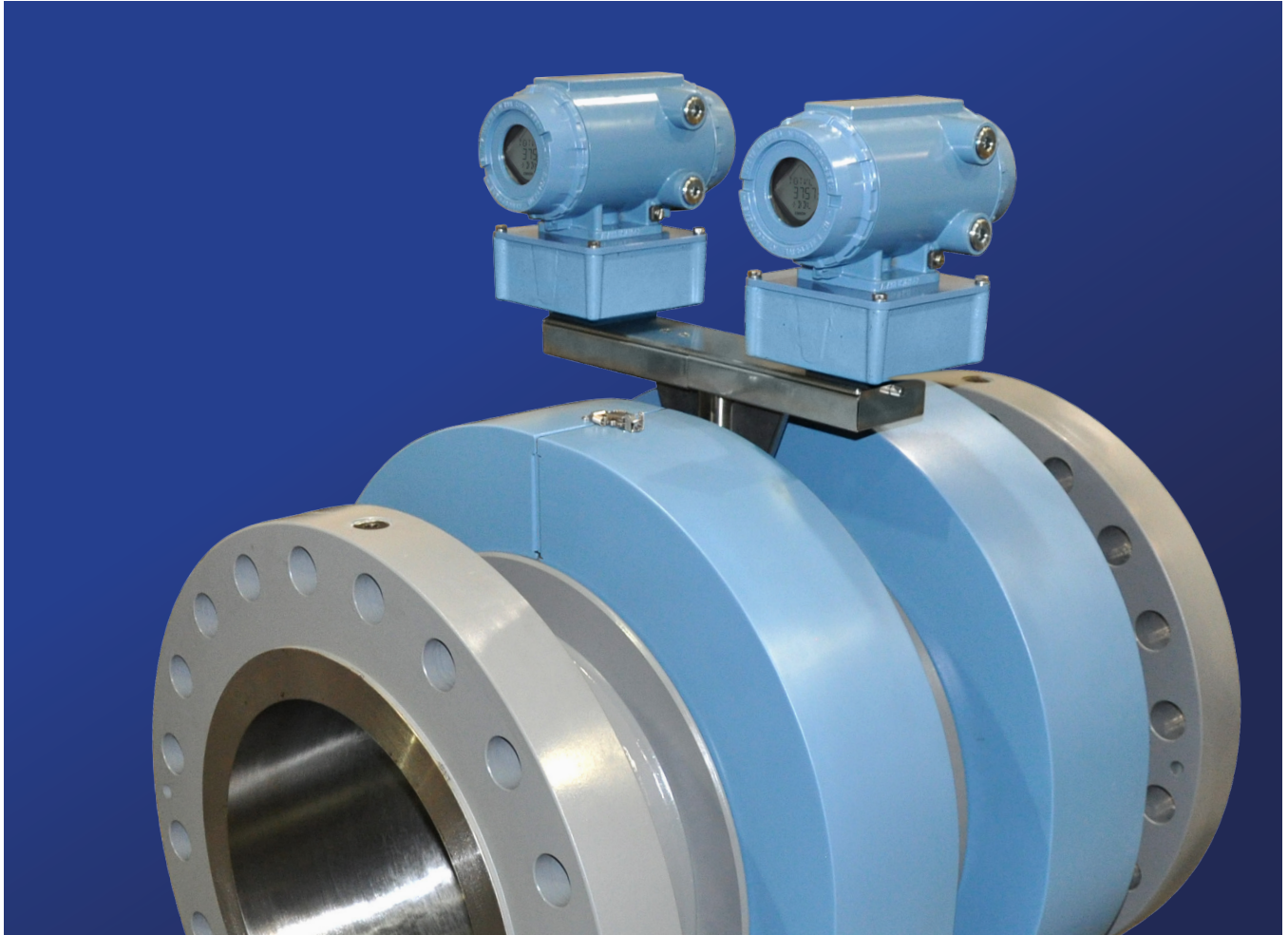
m e a s u r e m e n t i n s t r u m e n t s

## PRODUCT DATASHEET

[www.high-accuracy.com](http://www.high-accuracy.com)

# Daniel™ 3417

## Redundant 4+4 Four-Path Gas Ultrasonic Flow Meter





# Daniel 3417 4+4 Gas Ultrasonic Flow Meter

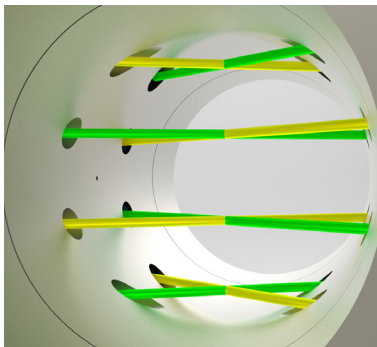
## Redundancy for Superior Reliability

Engineered to maximize uptime while offering superior custody transfer accuracy, the new, fully-redundant Daniel 3417 Gas Ultrasonic Flow Meter delivers the ultimate in measurement verification and validation. The advanced, dual-configuration meter combines the power of two field-proven Daniel four-path British Gas-design meters in a single body, enabling two independent measurements in one meter run.

Available in DN200 to DN1050 (8-in to 42-in<sup>(1)</sup>) line sizes, each standard 3417 meter is equipped with powerful Daniel 3410 Series Electronics and rugged, reliable Daniel T-20 Series Transducers that are engineered for wet, rich and/or dirty gas applications. A new patented transducer synchronization method ensures the meter's electronics provide the highest sampling rates possible, resulting in more stable ultrasonic signals for better flow resolution.

To further reduce measurement uncertainty, the electronics' firmware processes AGA 10 speed of sound calculations in real time for comparison with the meter's SOS measurement<sup>2</sup>. Significant deviations between the two readings may signal upstream process upsets, enabling operators to rapidly troubleshoot and minimize the potential for LAUF product.

An updated version of Daniel MeterLink software gives operators advanced insight and allows real-time monitoring of the meter from a PC or laptop, enabling immediate diagnosis of potential flow disturbances to help eliminate unplanned shutdowns. In addition, the meter's extensive hourly and daily logging enables operators to trend the two independent meters over time, helping extend calibration cycles for significant cost reduction.



**Figure 1: Based on the field-proven British Gas design, the fully-redundant Daniel 3417 meter combines two sets of four direct paths for ultra-reliable custody transfer measurement.**

## Typical Application

- Custody transfer for natural gas

## Application Sites

- Pipeline interconnects
- Pipelines (no bypass)
- Border stations
- Offshore production
- Industry/city gates
- Power plants
- LNG regasification terminals

## Features and Benefits

- Fully-redundant model with two field-proven Daniel 4-path chordal, British Gas-design meters (OIML Accuracy Class 0.5) in one body offering:
  - Direct inputs for pressure, temperature and gas composition that allow calculations of AGA 8 Compressibility and optional AGA 10 speed of sound
  - Automatic calculations and totalization of corrected volume rates, mass rates and energy rates
  - Ethernet connectivity for expedited data transfer
- Ultra-reliable dual configuration with two independent measurements for multiple applications, including:
  - Verification of measurement performance and/or as a complete backup in remote locations
  - Pay-check configuration between two contracting parties for significant savings
  - Bi-directional measurement with one transmitter dedicated to forward flow and one to reverse flow
- Patented transducer synchronization method increases sampling speed, resulting in faster detection of flow disturbances to expedite alerts and troubleshooting
- Daniel 3410 Series Electronics provide an expandable platform and an expansive archive data log to simplify accounting and dispute resolution
  - Trending data captured by two independent transmitters can also help extend calibration cycles
- New Type 4 CPU Module offers additional I/O with five frequency or digital outputs and one digital input that can be configured as the sixth output if needed
- Local LED displays (optional) on each transmitter offer up to ten user-selectable scrolling variables
- High rangeability (>100:1) that eliminates an additional meter run
- 5D upstream piping requirement (with flow conditioner) for offshore rigs and other sites with limited straight run

(1) Consult factory on meter sizes above DN900 (36-in).

(2) Requires a Continuous Flow Analysis software key.

# Standard Specifications

Please consult a Daniel product specialist if requirements are outside of the listed specifications. Other product and material offerings may be available depending on the application.

## Meter Specifications

### Characteristics

- Two redundant 4-path (eight transducers per transmitter) chordal design

### Meter Performance

- Flow calibrated accuracy is  $\pm 0.1\%$  of reading over entire flow calibration range
- Repeatability is  $\pm 0.05\%$  of reading for 1.5 to 30.5 m/s (5 to 100 ft/s)

### Velocity Range

- Nominal 0 to 30 m/s (0 to 100 fps) with over-range performance exceeding 38 m/s (125 fp/s) on some sizes
- Meter meets or exceeds AGA 9 2007 Edition / ISO 17089 performance specifications

**Table 1A: AGA 9 / ISO 17089 Flow Rate Values  
(Metric Units)**

Meter Size (DN)	200 to 600	750	900	1050
$q_{min}$ (m/s)	0.5	0.5	0.5	0.5
$q_t$ (m/s)	3.048	2.591	2.29	CF
$q_{max}$ (m/s)	30.48	25.91	22.86	CF

**Table 1B: AGA 9 / ISO 17089 Flow Rate Values  
(US Customary Units)**

Meter Size (in)	8 to 24	30	36	42
$q_{min}$ (ft/s)	1.7	1.7	1.7	1.7
$q_t$ (ft/s)	10	8.5	7.5	CF
$q_{max}$ (ft/s)	100	85	75	CF

## Electronics Performance

### Power per Transmitter

- 10.4 VDC to 36 VDC
- 8 watts typical; 15 watts maximum

### Total Meter Consumption

- 16 watts typical; 30 watts maximum

## Mechanical Ratings

### Line Sizes

- DN200 to DN1050 (8-in to 42-in)<sup>(1)</sup> with British Gas (BG) orientation

### Operating Gas Temperature (Transducers)

- T-21: -20°C to +100°C (-4°F to +212°F)
- T-41: -50°C to +100°C (-58°F to +212°F)
- T-22: -50°C to +100°C (-58°F to +212°F)

### Operating Pressure Range (Transducers)

- T-21/T-41/T-22: 689 to 27,579 kPag (100 to 4,000 psig)
- T-21/T-41: 345 kPag (50 psig) minimum operating pressure available with reduced  $Q_{max}$ <sup>(2)</sup>
- T-22: 0 to 689 kPag (0 to 100 psig)<sup>(3)</sup>

### Flanges

- Raised Face (RF) and Ring Type Joint (RTJ) for PN 50 to 250 (ANSI Classes 300 to 1,500)
- Compact flanges/hub end connectors (optional)

### NACE, NORSOK and PED Compliance

- Designed for NACE compliance<sup>(4)</sup>
- NORSOK available upon request
- PED available upon request

## Electronics Ratings

### Operating Temperature

- 40°C to +60°C (-40°F to +140°F)

### Operating Relative Humidity

- Up to 95% non-condensing

### Storage Temperature

- 40°C to +85°C (-40°F to +185°F) with a low temperature storage limit of -20°C (-4°F) for T-21 transducers and -50°C (-58°F) for T-41/T-22 transducers

### Electronic Housing

- Integral mount

(1) Consult factory on meter sizes above DN900 (36-in).

(2) Refer to page 9 for additional information pertaining to operation limits.

(3) For low pressure applications below 689 kPag (100 psig), the meter must be equipped with isolated transducer mounts.

(4) It is the equipment user's responsibility to select the materials suitable for the intended services.

## Materials of Construction

The materials of construction are dependent upon application requirements that must be specified by the customer. If needed, a Daniel product specialist can provide material guidance.

### Material Specifications

#### Body and Flange

##### Forgings

- ASTM A350 Gr LF2 Carbon Steel<sup>(1)</sup>  
-46°C to +150°C (-50°F to +302°F)
- ASTM A350 Gr LF2 Carbon Steel<sup>(1)</sup>  
-50°C to +150°C (-58°F to +302°F)
- ASTM A182 Gr F316/F316L Stainless Steel (Dual Certified)  
-46°C to +150°C (-50°F to +302°F)
- ASTM A182 Gr F51 Duplex Stainless Steel<sup>(2)</sup>  
-50°C to +150°C (-58°F to +302°F)
- ASTM A105 Carbon Steel  
-29°C to +150°C (-20°F to +302°F)

#### Enclosure Housing

- Standard: ASTM B26 Gr A356.0 T6 Aluminum
- Optional: ASTM A351 Gr CF8M Stainless Steel

#### Electronics Bracket

##### Stainless Steel Material

- 316SS

#### Transducer Components

##### Transducer Mounts and Holders O-rings

- Standard: Nitrile Butadiene Rubber (NBR)
- Other materials available

##### Transducer Mounts and Holders

- ASTM A564 Type 630 Stainless Steel Mounts
- ASTM A479 316L Stainless Steel Holders
- INCONEL® ASTM B446 (UNS N06625) Gr 1 Mount (optional)
- INCONEL ASTM B446 (UNS N06625) Gr 1 Holder (optional)

### Paint Specifications

#### Body and Flange Exterior

##### Carbon Steel Body Material

- 2 coat paint; inorganic zinc primer and acrylic lacquer topcoat (standard)

##### Stainless Steel or Duplex Body Material

- Paint (optional)

#### Transducer Shroud

##### Aluminum Material

- Powder coated

#### Enclosure Housing

##### Aluminum Material

- 100% conversion coated and exterior coated with a polyurethane enamel

##### Stainless Steel Material

- Passivated (optional)

**Table 2A: Body and Flange Maximum Pressure Ratings by Construction Materials**  
[bar Meter Sizes DN200 to DN1050]<sup>(3)</sup>

PN	Forged Carbon Steel	Forged 316/316L SS	Duplex SS
50	51.1	49.6	51.7
100	102.1	99.3	103.4
150	153.2	148.9	155.1
200	255.3	248.2	258.6

**Table 2B: Body and Flange Maximum Pressure Ratings by Construction Materials**  
[psi Meter Sizes 8-in to 42-in]<sup>(3)</sup>

ANSI Class <sup>(4)</sup>	Forged Carbon Steel	Forged 316/ 316L SS	Duplex SS
300	740	720	750
600	1,480	1,440	1,500
900	2,220	2,160	2,250
1,500	3,705	3,600	3,750

(1) Impact tested per specified ASTM standard.

(2) A995 4A material is not yet approved in Canada.

(3) Pressure rating information is for -29°C to +38°C (-20°F to +100°F). Other temperatures may reduce the maximum pressure rating of the materials.

## Meter Sizing: Metric Units

Tables 3A and 3B can be used to determine the flow range at reference conditions for all meter sizes. All calculations are based on Schedule 40 bore, +15°C and typical gas composition (AGA 8 Amarillo). These values are intended to be a guide in sizing. Please confirm meter sizing with a Daniel product specialist prior to order placement.

### Calculating Meter Capacity

To calculate a volume rate for a given velocity, first find the capacity (flow rate) in table 3A or 3B for the meter size and operating pressure. Next, multiply the capacity by the ratio of the desired velocity divided by 30.5 m/s to obtain the desired volume rate.

The example below illustrates how to determine the hourly flow rate at 21 m/s for a DN200 meter operating at 4,500 kPag:

If Flow Rate = 178 MSCMH and Velocity = 21 m/s, the calculation is:  $\frac{178 \text{ MSCMH} \times 21 \text{ m/s}}{30.5 \text{ m/s}} = 122.6 \text{ MSCMH}$

		Table 3A: Flow Rates (MSCMH)								
		Based Upon Max Rated Velocity [DN200 to DN600 = 30.5 m/s] [DN750 = 25.9 m/s] [DN900 = 22.9 m/s]								
Meter Size (DN)		200	250	300	400	500	600	750	900	1050
Operating Pressure (kPag)	1,000	39	62	88	139	218	315	432	550	CF
	1,500	58	91	129	204	320	463	635	809	CF
	2,000	77	121	171	270	425	615	843	1,074	CF
	2,500	96	151	214	339	533	770	1,056	1,345	CF
	3,000	116	182	259	408	642	929	1,274	1,622	CF
	3,500	136	214	304	480	754	1,091	1,496	1,905	CF
	4,000	156	247	350	553	869	1,257	1,724	2,195	CF
	4,500	178	280	397	627	987	1,427	1,957	2,491	CF
	5,000	199	314	446	704	1,107	1,600	2,195	2,794	CF
	5,500	221	349	495	781	1,229	1,778	2,438	3,104	CF
	6,000	244	384	545	861	1,354	1,959	2,686	3,420	CF
	6,500	267	420	597	942	1,482	2,143	2,939	3,742	CF
	7,000	290	457	649	1,025	1,612	2,331	3,197	4,071	CF
	7,500	314	495	702	1,109	1,744	2,523	3,460	4,405	CF
	8,000	338	533	757	1,195	1,879	2,718	3,727	4,745	CF
	8,500	363	572	812	1,281	2,015	2,915	3,997	5,090	CF
9,000	388	611	867	1,369	2,154	3,115	4,272	5,439	CF	
9,500	413	651	924	1,458	2,294	3,318	4,550	5,793	CF	
10,000	438	691	981	1,548	2,435	3,522	4,830	6,149	CF	

		Table 3B: Flow Rates (MMSCMD)								
		Based Upon Max Rated Velocity [DN200 to DN600 = 30.5 m/s] [DN750 = 25.9 m/s] [DN900 = 22.9 m/s]								
Meter Size (DN)		200	250	300	400	500	600	750	900	1050
Operating Pressure (kPag)	1,000	0.941	1.484	2.106	3.325	5.229	7.563	10.372	13.205	CF
	1,500	1.384	2.182	3.097	4.889	7.690	11.122	15.251	19.418	CF
	2,000	1.837	2.895	4.110	6.489	10.206	14.761	20.242	25.773	CF
	2,500	2.300	3.626	5.147	8.126	12.780	18.485	25.348	32.273	CF
	3,000	2.774	4.373	6.207	9.800	15.414	22.293	30.571	38.923	CF
	3,500	3.259	5.137	7.292	11.512	18.107	26.189	35.914	45.725	CF
	4,000	3.755	5.919	8.401	13.264	20.862	30.174	41.378	52.682	CF
	4,500	4.262	6.718	9.536	15.055	23.679	34.248	46.964	59.795	CF
	5,000	4.780	7.535	10.695	16.885	26.558	38.412	52.674	67.065	CF
	5,500	5.309	8.369	11.880	18.755	29.499	42.665	58.508	74.492	CF
	6,000	5.850	9.221	13.089	20.664	32.502	47.009	64.463	82.075	CF
	6,500	6.401	10.090	14.322	22.612	35.565	51.439	70.538	89.810	CF
	7,000	6.963	10.975	15.579	24.596	38.686	55.953	76.729	97.692	CF
	7,500	7.535	11.877	16.859	26.616	41.863	60.549	83.031	105.716	CF
	8,000	8.116	12.793	18.160	28.670	45.094	65.221	89.438	113.873	CF
	8,500	8.706	13.723	19.480	30.754	48.372	69.962	95.940	122.151	CF
9,000	9.304	14.666	20.818	32.866	51.694	74.766	102.528	130.539	CF	
9,500	9.909	15.619	22.170	35.002	55.053	79.625	109.190	139.021	CF	
10,000	10.519	16.580	23.535	37.157	58.442	84.527	115.913	147.581	CF	

## Meter Sizing: US Customary Units

Tables 4A and 4B can be used to determine the flow range at reference conditions for all meter sizes. All calculations are based on Schedule 40 bore, +60°F and typical gas composition (AGA 8 Amarillo). These values are intended to be a guide in sizing. Please confirm meter sizing with a Daniel product specialist prior to order placement.

### Calculating Meter Capacity

To calculate a volume rate for a given velocity, first find the capacity (flow rate) in table 4A or 4B for the meter size and operating pressure. Next, multiply the capacity by the ratio of the desired velocity divided by 100 ft/s to obtain the desired volume rate.

The example below illustrates how to determine the hourly flow rate at 70 ft/s for an 8-inch meter operating at 800 psig:

If Flow Rate = 7,842 MSCFH and Velocity = 70 ft/s, the calculation is:  $\frac{7,842 \text{ MSCFH} \times 70 \text{ ft/s}}{100 \text{ ft/s}} = 5,489.4 \text{ MSCFH}$

		Table 4A: Flow Rates (MSCFH)								
		Based Upon Max Rated Velocity [8 to 24 in = 100 ft/s] [30 in = 85 ft/s] [36 in = 75 ft/s]								
Meter Size (in)		8	10	12	16	20	24	30	36	42
Operating Pressure (psig)	100	989	1,559	2,213	3,494	5,495	7,948	10,910	13,862	CF
	200	1,880	2,963	4,207	6,641	10,446	15,108	20,738	26,349	CF
	300	2,799	4,412	6,263	9,888	15,552	22,493	30,875	39,229	CF
	400	3,747	5,906	8,384	13,236	20,819	30,111	41,331	52,515	CF
	500	4,725	7,448	10,572	16,690	26,251	37,968	52,117	66,219	CF
	600	5,733	9,037	12,828	20,252	31,854	46,071	63,239	80,350	CF
	700	6,772	10,675	15,153	23,923	37,627	54,422	74,701	94,914	CF
	800	7,842	12,362	17,547	27,703	43,572	63,020	86,504	109,910	CF
	900	8,943	14,096	20,009	31,590	49,686	71,863	98,642	125,333	CF
	1,000	10,073	15,877	22,537	35,581	55,964	80,943	111,105	141,169	CF
	1,100	11,231	17,702	25,128	39,671	62,396	90,246	123,875	157,394	CF
	1,200	12,414	19,567	27,774	43,850	68,969	99,752	136,923	173,973	CF
	1,300	13,619	21,467	30,471	48,107	75,665	109,437	150,217	190,865	CF
	1,400	14,842	23,395	33,208	52,428	82,462	119,267	163,711	208,009	CF
	1,500	16,079	25,344	35,975	56,797	89,333	129,205	177,352	225,341	CF
	1,600	17,323	27,306	38,760	61,193	96,247	139,205	191,079	242,782	CF
1,700	18,570	29,270	41,548	65,595	103,172	149,221	204,826	260,250	CF	
1,800	19,811	31,227	44,326	69,981	110,069	159,197	218,520	277,649	CF	
1,900	21,041	33,166	47,079	74,327	116,905	169,083	232,090	294,891	CF	
2,000	22,255	35,079	49,793	78,612	123,645	178,832	245,472	311,894	CF	

		Table 4B: Flow Rates (MMSCFD)								
		Based Upon Max Rated Velocity [8 to 24 in = 100 ft/s] [30 in = 85 ft/s] [36 in = 75 ft/s]								
Meter Size (in)		8	10	12	16	20	24	30	36	42
Operating Pressure (psig)	100	23.7	37.4	53.1	83.9	131.9	190.8	261.8	332.7	CF
	200	45.1	71.1	101.0	159.4	250.7	362.6	497.7	632.4	CF
	300	67.2	105.9	150.3	237.3	373.2	539.8	741.0	941.5	CF
	400	89.9	141.8	201.2	317.7	499.6	722.7	991.9	1,260.4	CF
	500	113.4	178.7	253.7	400.6	630.0	911.2	1,250.8	1,589.3	CF
	600	137.6	216.9	307.9	486.1	764.5	1,105.7	1,517.7	1,928.4	CF
	700	162.5	256.2	363.7	574.2	903.1	1,306.1	1,792.8	2,277.9	CF
	800	188.2	296.7	421.1	664.9	1,045.7	1,512.5	2,076.1	2,637.8	CF
	900	214.6	338.3	480.2	758.2	1,192.5	1,724.7	2,367.4	3,008.0	CF
	1,000	241.7	381.1	540.9	854.0	1,343.1	1,942.6	2,666.5	3,388.1	CF
	1,100	269.5	424.8	603.1	952.1	1,497.5	2,165.9	2,973.0	3,777.5	CF
	1,200	297.9	469.6	666.6	1,052.4	1,655.3	2,394.0	3,286.2	4,175.4	CF
	1,300	326.9	515.2	731.3	1,154.6	1,816.0	2,626.5	3,605.2	4,580.7	CF
	1,400	356.2	561.5	797.0	1,258.3	1,979.1	2,862.4	3,929.1	4,992.2	CF
	1,500	385.9	608.3	863.4	1,363.1	2,144.0	3,100.9	4,256.4	5,408.2	CF
	1,600	415.8	655.3	930.2	1,468.6	2,309.9	3,340.9	4,585.9	5,826.8	CF
1,700	445.7	702.5	997.2	1,574.3	2,476.1	3,581.3	4,915.8	6,246.0	CF	
1,800	475.5	749.5	1,063.8	1,679.5	2,641.7	3,820.7	5,244.5	6,663.6	CF	
1,900	505.0	796.0	1,129.9	1,783.8	2,805.7	4,058.0	5,570.2	7,077.4	CF	
2,000	534.1	841.9	1,195.0	1,886.7	2,967.5	4,292.0	5,891.3	7,485.5	CF	

## Local LCD Display

Each Daniel 3410 Series transmitter offers an optional LCD display with a three-line readout that indicates variable name, variable value and the engineering unit. The displays can easily be configured via Daniel MeterLink software or Emerson's AMST™ 475 Field Communicator with HART® protocol.



**Figure 2: Optional LCD displays scroll the user-selected variables noted in Table 5.**

The local display shows up to 10 items which are user selectable from 26 variables. The display can be configured to scale volume units as actual or 000's, with an adjustable time base of seconds, hours or days. The scroll rate can be adjusted from 1 to 100 seconds (default 5 seconds).

Table 5: User Selectable Display Variables	
Variables	Description
Volumetric Flow Rate	Uncorrected (actual) Corrected (standard or normal)
Average Flow Velocity	(no description necessary)
Average Speed of Sound	(no description necessary)
Pressure	Flowing, if utilized
Temperature	Flowing, if utilized
Frequency Output	1A, 1B, 2A or 2B
Frequency Output K-factor	Channel 1 or 2
Analog Output	1 or 2
Current Day's Volume Totals	Uncorrected or Corrected (forward or reverse)
Previous Day's Volume Totals	Uncorrected or Corrected (forward or reverse)
Total Volume Totals (non-reset)	Uncorrected or Corrected (forward or reverse)

Table 6: I/O Connections Per Transmitter			
	I/O Connection Type	Qty	Description
<b>Communication</b>			
<b>Serial Communications</b>	Serial RS232/RS485 Port	1	<ul style="list-style-type: none"> <li>▪ Modbus RTU/ASCII</li> <li>▪ 115 kbps baud rate</li> <li>▪ RS232/RS485 Full Duplex</li> <li>▪ RS485 Half Duplex</li> </ul>
	Ethernet Port (TCP/IP) 100BaseT	1	<ul style="list-style-type: none"> <li>▪ Modbus TCP</li> </ul>
<b>Digital and Analog Inputs</b>			
<b>Digital Input<sup>(1)</sup></b>	Contact Closure	1	<ul style="list-style-type: none"> <li>▪ Status</li> <li>▪ Single polarity</li> </ul>
<b>Analog Inputs<sup>(2)</sup></b>	4-20 mA	2	<ul style="list-style-type: none"> <li>▪ AI-1 Temperature<sup>(3)</sup></li> <li>▪ AI-2 Pressure<sup>(3)</sup></li> </ul>
<b>Digital, Analog and Frequency Outputs</b>			
<b>Frequency/Digital Outputs</b>	TTL/Open Collector	5	<ul style="list-style-type: none"> <li>▪ User Configurable (can configure Digital Input as 6th Frequency/Digital Output)</li> </ul>
<b>Analog Output<sup>(2, 4)</sup></b>	4-20 mA	1	<ul style="list-style-type: none"> <li>▪ Independently configurable analog output</li> <li>▪ HART® 7 Compliant</li> </ul>

### Optional I/O Expansion Slot: 1 RS232 or 1 RS485 Half Duplex, 2-Wire available per transmitter

Note: Maximum wire gauge is 18 AWG

(1) The analog-to-digital conversion accuracy is within  $\pm 0.05\%$  of full scale over the operating temperature range.

(2) A 24 volt DC power supply is available to provide power to the sensors.

(3) AI-1 and AI-2 are electronically isolated and operate in sink mode. The input contains a series resistor for HART Communicators to be connected for sensor configuration.

(4) The analog output zero scale offset error is within  $\pm 0.1\%$  of full scale and gain error is within  $\pm 0.2\%$  of full scale. The total output drift is within  $\pm 50$  ppm of full scale per °C.

## Diagnostics and Software

Expedite delivery of more in-depth diagnostics by activating the optional Continuous Flow Analysis (CFA)<sup>(1)</sup> feature in the Daniel 3417 meter's firmware. CFA helps minimize flow measurement uncertainty by determining the root cause of the diagnostic parameter indication. Using these intelligent gas flow diagnostics, operators can more easily maintain meter health and ensure the highest measurement integrity.

Every Daniel ultrasonic flow meter is provided with advanced MeterLink™ Software to simplify monitoring and troubleshooting. This advanced software displays a number of performance-based diagnostics that indicate meter health. In addition, dynamic flow-based diagnostics help operators identify flow disturbances that may affect measurement uncertainty.

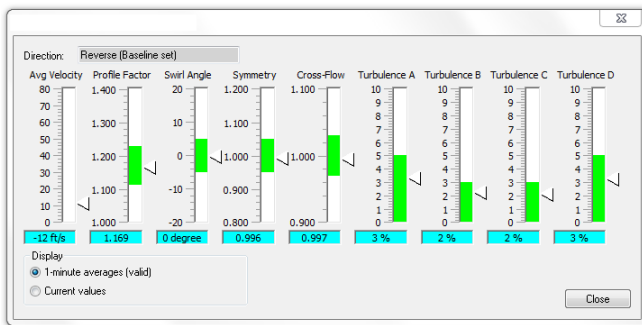


Figure 3A: Daniel MeterLink Baseline Viewer<sup>(1)</sup>

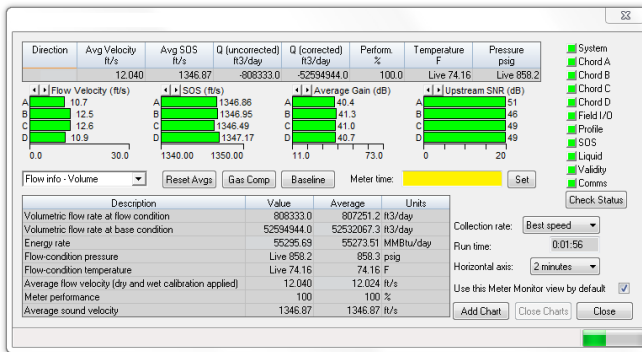


Figure 3B: MeterLink Monitor Screen

- MeterLink software is supplied with meter at no charge
- MeterLink is required for transmitter configuration
  - Meters also configurable with AMS Device Manager or 475 Field Communicator if HART is used
- MeterLink software requires RS232, RS485 full duplex or Ethernet (recommended)
- Supports Microsoft® Vista™, 7, 8.1 and 10
- Microsoft Office 2003-2016

Table 7: Features of Meter and MeterLink <sup>(2)</sup>				
		With Continuous Flow Analysis Feature	Without Continuous Flow Analysis Feature	
Operation	Monitor Screen	●	●	
	Chart Diagnostic Data	●	●	
	Multiple Charts	●	●	
	Charts with Green Limit Bands	●	●	
	View Waveforms	●	●	
	Configurable Modbus GC Component Data Table*	●	●	
	AGA 10/Meter SOS Comparison*	●	●	
	Transducer Health Monitoring*	●	●	
	AGA 10 Calculator (offline)	●	●	
	SNR displayed in dB	●	●	
History	Improved Help Topics/Links	●	●	
	Baseline Viewer™ (4-path only)	●	●	
	Maintenance Logs	●	●	
	Trend Maintenance Logs	●	●	
	Merge Event Logs	●	●	
	Hourly Logs (100 days)*	●	●	
	Daily Logs (365 days)*	●	●	
	Hourly/Daily Log Graphing	●	●	
	Configuration	Field Setup Wizard	●	●
		Meter Directory Support	●	●
Automatic File Naming		●	●	
Compare Configurations from Logs		●	●	
Analog Input Calibration		●	●	
Local Display Configurator		●	●	
Modbus GC Component Data Table Configurator		●	●	
Flow Calibration Wizard		●	●	
Modbus TCP Server Configuration		●	●	
Baseline Configuration Wizard		●	●	
Alarms	Alarm/Audit/System Logs*	●	●	
	Display New Latched Alarms	●	●	
	Severity Alarm Display	●	●	
	Bore Buildup Alert	●	●	
	Blockage Alert	●	●	
	Abnormal Profile Alert	●	●	
	Liquid Detection Alert	●	●	
Reverse Flow Alert	●	●		

\* Features highlighted in blue represent functions of the meter.

(1) Requires a Continuous Flow Analysis software key.

(2) MeterLink does not support Mark II Gas Ultrasonic Meters.

## Safety and Compliance


The Daniel 3417 gas ultrasonic flow meter meets worldwide industry standards for electrical and intrinsic safety certifications and approvals. Consult with a Daniel technical specialist for a complete list of agencies and certifications.

### Safety Classifications

#### Underwriters Laboratories (UL / cUL)

- Hazardous Locations — Class I, Division 1, Groups C and D

#### CE Marked to Directives

- Explosive Atmospheres (ATEX)
- Certificate — Demko II ATEX 1006133X
- Marking —  II 2G Ex d ia IIB T4 Gb  
(-40°C ≤ T ≤ +60°C)
- Pressure Equipment Directive (PED)
- Electromagnetic Compatibility (EMC)

#### INMETRO

- Certificate — NCC 11.0163 X
- Marking — Ex d [ia] IIB T4 Gb IP66W

#### International Electrotechnical Commission (IECEX)

- Marking — Ex d ia IIB T4

#### Canadian Registration Number

- Certificate — 0F14855

### Environmental Ratings

#### Aluminum

- NEMA 4
- IP66 to EN60529

#### Stainless Steel

- NEMA 4X
- IP66 to EN60529

### Metrology Approval

#### OIML

- OIML R137-1&2 Edition 2012(E)
- Class 0.5

#### MID

- Directive 2014/32/EU (MID MI-002)
- Class 1.0

#### Measurement Canada

- Approval — AG-0623

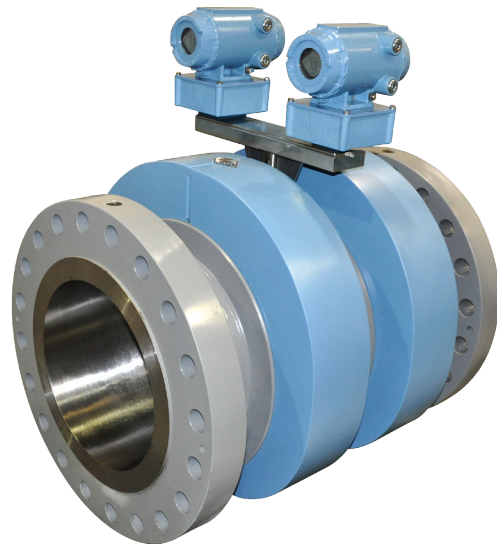


Figure 4A: Dual transducer shrouds are standard on DN400 (16-in) and larger Model 3417 meters.



Figure 4B: A single transducer shroud is standard on DN200 to DN300 (8-in to 12-in) Model 3417 meters.

# Operation Limits

Consult a Daniel product specialist if requirements are outside of the operation limits shown below for T-21/T-41/T-22 transducers.

Table 8A: Recommended Maximum Velocity for DN300 and Smaller Line Size Meters (Metric Units)					
Nominal Meter Size (DN)	Maximum Velocity Rating at 0 kPag or Greater (m/s) <sup>(1)</sup>	Capacity at Maximum Rated Velocity (ACMH) <sup>(1)</sup>			Schedule STD Bore (mm)
200	30.5	3,541			202.7
250	30.5	5,582			254.5
300	30.5	8,006			303.2

Table 8B: Recommended Maximum Velocity for DN400 and Larger Line Size Meters (Metric Units)					
Nominal Meter Size (DN)	Maximum Velocity Rating at 345 kPag (m/s)	Capacity between 345 and 689 kPag (ACMH) <sup>(2)</sup>	Maximum Velocity Rating at 689 kPag or Greater (m/s)	Capacity at Maximum Rated Velocity (ACMH) <sup>(2)</sup>	Schedule STD Bore (mm)
400	15.2	6,465	30.5	12,930	381
500	15.2	10,301	30.5	20,603	477.9
600	15.2	15,027	30.5	30,055	574.7
750	13.7	21,406	26	40,433	743
900	11.4	25,907	23	51,814	895.4
1050	11.4	34,479	23	70,955	1047.8

Table 8C: Recommended Maximum Velocity for 12-in and Smaller Line Size Meters (US Customary Units)					
Nominal Meter Size (in)	Maximum Velocity Rating at 0 psig or Greater (ft/s) <sup>(1)</sup>	Capacity at Max Rated Velocity (ACFH) <sup>(1)</sup>			Schedule STD Bore (in)
8	100	125,068			7.981
10	100	197,136			10.020
12	100	282,743			12.000

Table 8D: Recommended Maximum Velocity for 16-in and Larger Line Size Meters (US Customary Units)					
Nominal Meter Size (in)	Maximum Velocity Rating at 50 psig (ft/s)	Capacity between 50 to 100 psig (ACFH) <sup>(2)</sup>	Maximum Velocity Rating at 100 psig or Greater (ft/s)	Capacity at Max Rated Velocity (ACFH) <sup>(2)</sup>	Schedule STD Bore
16	50	228,318	100	456,635	15.250
20	50	363,799	100	727,598	19.250
24	50	530,696	100	1,061,392	23.250
30	45	755,952	85	1,427,909	29.250
36	37.5	914,912	75	1,829,824	35.250
42	37.5	1,252,879	75	2,505,758	41.250

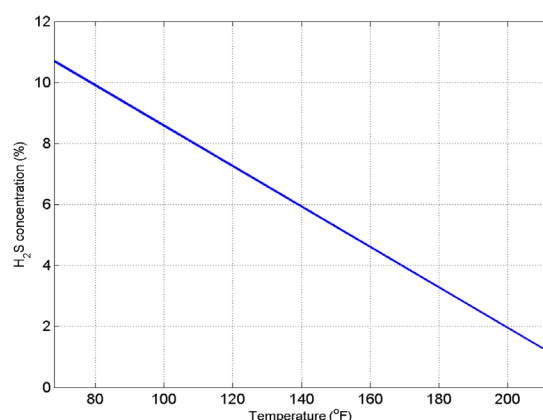
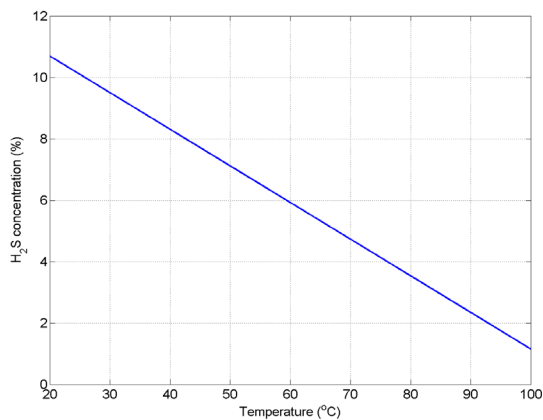
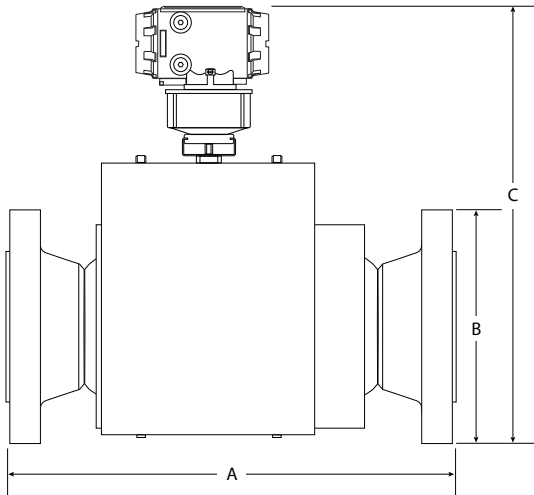


Figure 5: H<sub>2</sub>S Limits by Temperature for Daniel T-20 Series Transducers

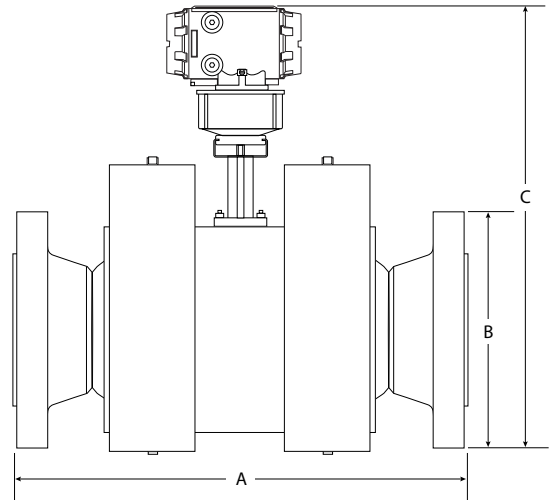
(1) Isolated transducer mounts required for DN300 (12-in) and smaller line size meters to achieve 0 to 345 kPag (0 to 100 psig).

(2) Capacities are for meter ID equivalent to Schedule 40 (or STD).

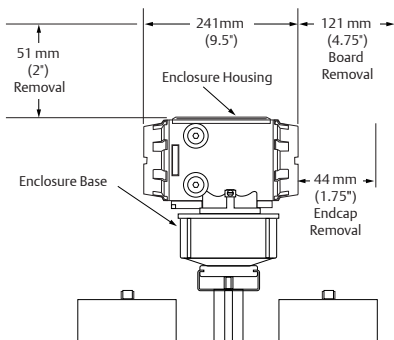
# Weights and Dimensions



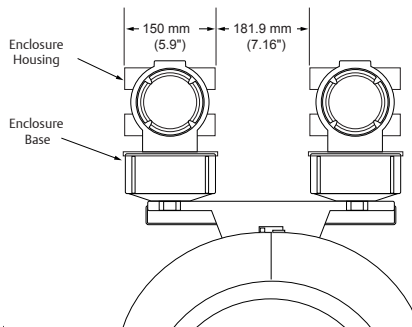
**Figure 6A: Dimension Key for DN200 to DN300 (8-in to 12-in) Meters with Single Transducer Shroud (See tables 9A and 9B)**



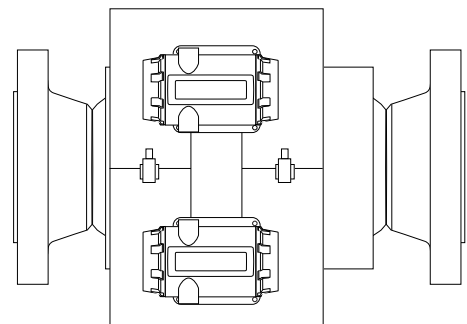
**Figure 6B: Dimension Key for DN400 and larger (16-in and larger) Meters with Dual Transducer Shrouds (See tables 9A and 9B)**



**Figure 6C: Dimensions of Enclosure Housing**



**Figure 6D: Additional Dimensions of Enclosure Housing**



**Figure 6E: Overhead View of Meter**

# Weights and Dimensions

The Meter Dimension Key diagrams (Figures 5A and 5B) on page 10 illustrate the meter component measurements that correspond to A, B and C in the chart below. All weights and dimensions are based on the standard electronics enclosure. The certified approval drawing will include the actual weights and dimensions.

Table 9A: Weights and Dimensional Data (Metric Units)										
Nominal Line Size (DN)		200	250	300	400	500	600	750	900	1050
PN 50	Weight (kg)	535	635	771	998	1452	2177	2291	2858	CF
	A (mm)	846	859	927	953	1087	1207	1130	1181	CF
	B (mm)	381	445	521	648	775	914	1092	1270	CF
	C (mm)	790	843	902	1003	1125	1252	1420	1588	CF
PN 100	Weight (kg)	572	726	862	1089	1678	2404	2631	3334	CF
	A (mm)	902	940	991	1029	1156	1290	1219	1278	CF
	B (mm)	419	508	559	686	813	940	1130	1316	CF
	C (mm)	800	871	922	1024	1143	1265	1438	1610	CF
PN 150	Weight (kg)	651	862	1162	1624	2318	3597	4672	6908	CF
	A (mm)	991	1092	1201	1295	1349	1577	1562	1072	CF
	B (mm)	470	546	610	706	859	1041	1232	1461	CF
	C (mm)	820	889	950	1044	1174	1318	1524	1740	CF
PN 250	Weight (kg)	762	1075	1533	2327	3361	5185	CF	CF	CF
	A (mm)	1100	1265	1379	1499	1575	1816	CF	CF	CF
	B (mm)	483	584	673	826	986	1168	CF	CF	CF
	C (mm)	826	907	983	1102	1237	1382	CF	CF	CF

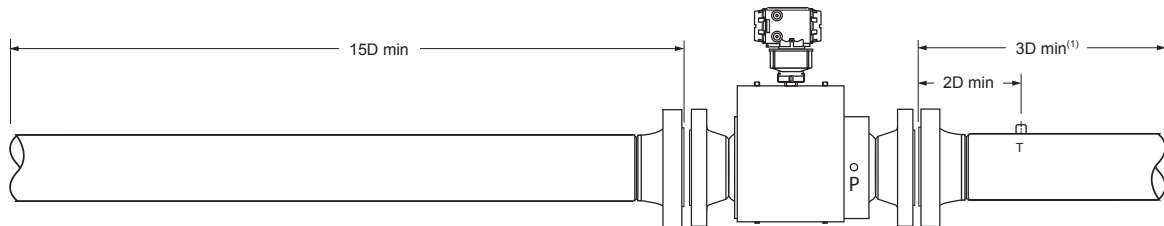
Table 9B: Weights and Dimensional Data (US Customary Units)										
Nominal Line Size (in)		8	10	12	16	20	24	30	36	42
300 ANSI	Weight (lb)	1180	1400	1700	2200	3200	4800	5050	6300	CF
	A (in)	33.3	33.8	36.5	37.5	42.8	47.5	44.5	46.5	CF
	B (in)	15	17.5	20.5	25.5	30.5	36	43	50	CF
	C (in)	31.1	33.2	35.5	39.5	44.3	49.3	55.9	62.5	CF
600 ANSI	Weight (lb)	1260	1600	1900	2400	3700	5300	5800	7350	CF
	A (in)	35.5	37	39	40.5	45.5	50.8	48	50.3	CF
	B (in)	16.5	20	22	27	32	37	44.5	51.8	CF
	C (in)	31.5	34.3	36.3	40.3	45	49.8	56.6	63.4	CF
900 ANSI	Weight (lb)	1435	1900	2560	3580	5110	7930	10300	15230	CF
	A (in)	39	43	47.3	51	53.1	62.1	61.5	67	CF
	B (in)	18.5	21.5	24	27.8	33.8	41	48.5	57.5	CF
	C (in)	32.3	35	37.4	41.1	46.2	51.9	60	68.5	CF
1500 ANSI	Weight (lb)	1680	2370	3380	5130	7410	11430	CF	CF	CF
	A (in)	43.3	49.8	54.3	59	62	71.5	CF	CF	CF
	B (in)	19	23	26.5	32.5	38.8	46	CF	CF	CF
	C (in)	32.5	35.7	38.7	43.4	48.7	54.4	CF	CF	CF

CF: Consult factory

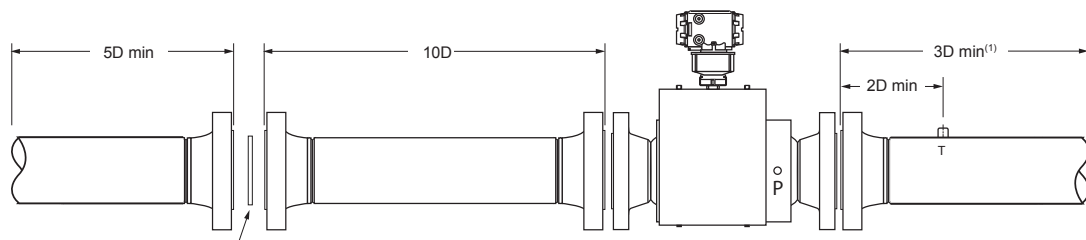
# Recommended Installation

## Recommended Pipe Lengths

The drawings below represent the manufacturer's recommended minimum pipe lengths for the installation of the Daniel 3417 Meter. The final recommendations are dependent upon application requirements that must be specified by the customer. Other lengths and flow conditioners can be accommodated. A Daniel product specialist can provide guidance as needed.

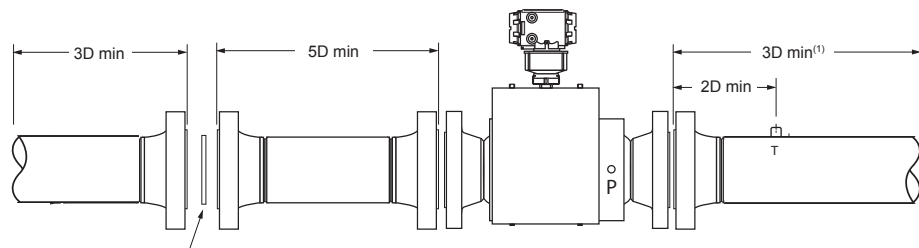


**Figure 7A: Piping Recommendation for Gas Ultrasonic Meter (No Flow Conditioner)**



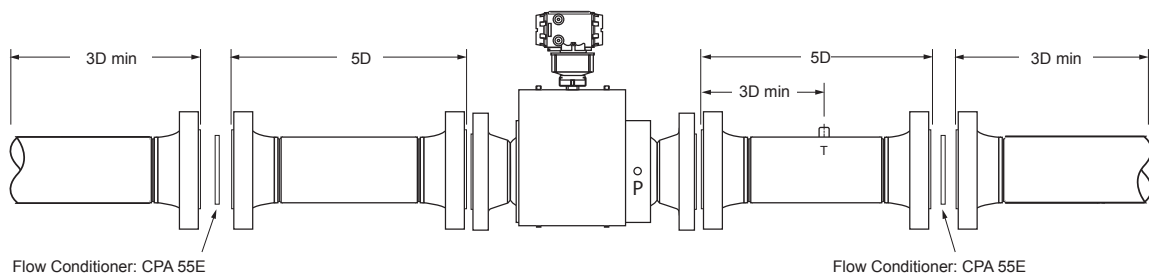
Flow Conditioner: Daniel Profiler, CPA 50E or CPA 55E

**Figure 7B: Piping Recommendation for Gas Ultrasonic Meter with a Flow Conditioner**



Flow Conditioner: CPA 55E

**Figure 7C: Piping Recommendation for Gas Ultrasonic Meter with a Flow Conditioner (Compact Installation)<sup>(2)</sup>**



Flow Conditioner: CPA 55E

Flow Conditioner: CPA 55E

**Figure 7D: Piping Recommendation for Bi-directional Gas Ultrasonic Meter with Flow Conditioners (Compact Installation)<sup>(2)</sup>**

Notes:

- 1. For best results, flow conditioning is recommended
- 2. D = Nominal pipe size in inches (i.e., 8-in pipe size; 10D = 80-in)
- 3. T = Temperature measurement location
- 4. Pressure measurement location provided on meter body

(1) Additional pipe length may be required for additional taps (i.e. sample probe, test well, etc.).

(2) Longer upstream lengths can increase long term baseline diagnostics stability. This configuration is not applicable to OIML installations.

















# HIGH ACCURACY

measurement instruments

Our offering:

	<p>Pressure Measurement</p>		<p>Level Measurement</p>
	<p>Temperature Measurement</p>		<p>Flow Measurement</p>
	<p>Marine Measurement &amp; Analytical</p>		<p>Gas Analysis</p>
	<p>Liquid Analysis</p>		<p>Flame and Gas Detection</p>
	<p>Tank Gauging</p>		<p>Wireless Infrastructure</p>
	<p>Acoustic &amp; Discrete</p>		

[www.high-accuracy.com](http://www.high-accuracy.com)

**Emerson Automation Solutions**

Daniel Measurement and Control, Inc.  
North America / Latin America:  
Headquarters  
USA - Houston, Texas  
T +1.713.467.6000  
USA Toll Free 1.888.FLOW.001

Europe: Stirling, Scotland, UK  
T +44.1786.433400  
Middle East, Africa: Dubai, UAE  
T +971.4.811.8100  
Asia Pacific: Singapore  
T +65.6777.8211

Scan with your smart  
phone for more  
information



**[www.Emerson.com/Daniel](http://www.Emerson.com/Daniel)**

©2017 Daniel Measurement and Control, Inc. All Rights Reserved. Unauthorized duplication in whole or in part is prohibited. Printed in the USA. DAN-GUSM-3417-DS-0417

The Emerson logo is a trademark and service mark of Emerson Electric Co. Daniel Measurement and Control, Inc. ("Daniel") is an Emerson Automation Solutions business unit and a subsidiary of Daniel Industries, Inc. The Daniel name and logo are trademarks of Daniel Industries, Inc. All other trademarks are the property of their respective companies.

**DANIEL™**

