



HIGH ACCURACY

m e a s u r e m e n t i n s t r u m e n t s

PRODUCT DATASHEET

www.high-accuracy.com

Product Data Sheet

PS-001292, Rev. G
October 2014

Micro Motion® Model 9739 Transmitters with MVD™ Technology

Micro Motion® Model 9739 transmitters with MVD™ technology deliver powerful features that make managing your process easier.



Advanced digital signal processing in a robust, proven design

- Robust housing and power options ideally suited for truck-mounted applications
- Same form factor as legacy Micro Motion RFT9739 transmitters for quick, easy replacement
- Significantly improved performance—such as in accuracy and turndown—compared to the legacy analog RFT9739

Wide variety of I/O and application capabilities to fit your needs

- High-speed DSP for accuracy under the toughest conditions—high noise, high turndown, and more
- Concentration and net flow measurement eliminates the need for additional instruments
- Petroleum measurement software automatically provides temperature corrected volumes from a single instrument



Micro Motion® Model 9739 transmitters with MVD technology

Micro Motion® 9739 MVD transmitters and controllers utilize MVD technology to deliver accurate, high-speed multivariable signals. Micro Motion transmitters are available with the following communication protocols: 4–20 mA, HART®, Wireless HART™, and Modbus®. That means you will always be able to receive the process information you need in a format that works for your installation. Micro Motion transmitters also carry advanced diagnostic tools allowing you to rest easy knowing your process is being monitored correctly.

MVD technology. MVD technology makes your Micro Motion meter work smarter. Front-end digital processing dramatically reduces signal noise and gives you faster response time compared to analog devices.

Only MVD technology allows you to:

- Measure multiple variables for accurate process control
- Identify and resolve problems easily with built-in smart diagnostics
- Upgrade transmitter functionality as needed

Model 9739 transmitter with MVD technology. The Micro Motion Model 9739 transmitter with MVD technology (or 9739 MVD) allows you to have advanced digital signal processing in a convenient wall- or pipe-mounted package, and can be used in custody transfer applications. With its single front access compartment, you can wire the transmitter easily from one main location.

The 9739 MVD transmitter is ideal for truck-mounted applications with its robust packaging and ability to accept as low as 12 VDC power.

Concentration measurement is easy with the 9739 MVD transmitter, too. You input the

concentration curves, and the multivariable transmitter can output mass flow, volume flow, density, temperature, concentration, and more.

Petroleum measurement is also available, and enables the correction for the effect of temperature on liquid volumes. This application calculates and applies a volume correction factor to volume measurement.

You can pair the 9739 MVD transmitter with the Smart Wireless THUM™ Adapter, allowing you to gain access to additional diagnostics and process information without added wiring costs.

Upgrading your RFT9739 transmitter. Because the 9739 MVD transmitter has the same installation requirements as the legacy RFT9739 transmitter, replacing a currently installed RFT9739 transmitter with a new 9739 MVD transmitter couldn't be easier.

Additionally, Micro Motion offers a 9739 MVD electronics module retrofit kit that allows you to upgrade existing RFT9739 transmitters to use MVD technology. The 9739 MVD electronics module has the same I/O capabilities as the RFT9739, so no rewiring is necessary to upgrade. And, because the retrofit requires that you use the currently installed transmitter housing base, the existing conduit connections are completely

Contents

Applications	3	Power supply	7
Liquid flow performance	3	Environmental limits	7
Density performance (liquid)	4	Environmental effects	7
Gas flow performance	4	Hazardous area classifications	8
Physical specifications	5	Dimensions	9
User interface	5	Ordering information: 9739 MVD transmitter . . .	11
Input/output signals	6	Ordering information: 9739 MVD retrofit kit	13

Applications

Concentration measurement	<p>Provides concentration measurement based on either industry-specific or liquid-specific units and relationships. Standard measurement options include:</p> <ul style="list-style-type: none">• Industry specific:<ul style="list-style-type: none">- °Brix- °Plato- °Balling- °Baumé at SG60/60- Specific gravity• Liquid specific:<ul style="list-style-type: none">- %HFCS- Concentration derived from reference density- Concentration derived from specific gravity <p>Additionally, the application can be customized for site-specific concentration measurement (such as %HNO₃, %NaOH).</p>
Petroleum measurement	<p>Provides process variables, such as temperature-corrected volume flow and API average density, calculated using the American Petroleum Institute (API) equations, specifically tables 5A, 5B, 5D, 6C, 23A, 23B, 23D, 24C, 53A, 53B, 53D, and 54C.</p>

Liquid flow performance

	Sensor model	
Mass flow accuracy⁽¹⁾⁽²⁾	ELITE	±0.10% of rate
	F-Series	±0.10% of rate
	H-Series	±0.10% of rate
	T-Series	±0.15% of rate
Volume flow accuracy⁽¹⁾⁽²⁾	ELITE	±0.10% of rate
	F-Series	±0.15% of rate
	H-Series	±0.15% of rate
	T-Series	±0.25% of rate
Repeatability⁽²⁾	ELITE	±0.05% of rate
	F-Series	±0.05% of rate
	H-Series	±0.05% of rate
	T-Series	±0.05% of rate

(1) Stated flow accuracy includes the combined effects of repeatability, linearity, and hysteresis. Because accuracies may vary for the D-Series sensors, refer to the product data sheet for further information.

(2) For details of flow accuracy and repeatability specifications, refer to the product data sheet for each sensor family.

Density performance (liquid)

	Sensor model	g/cm ³	kg/m ³
Accuracy⁽¹⁾	ELITE	±0.0005	±0.5
	F-Series	±0.001	±1.0
	H-Series	±0.001	±1.0
	T-Series	±0.002	±2.0
Repeatability⁽¹⁾	ELITE	±0.0002	±0.2
	F-Series	±0.0005	±0.5
	H-Series	±0.0005	±0.5
	T-Series	±0.0005	±0.5

(1) For details of flow accuracy and repeatability specifications, refer to the product data sheet for each sensor family. Because accuracies may vary for the D-Series sensors, refer to the product data sheet for further information.

Gas flow performance

	Sensor model	
Mass flow accuracy⁽¹⁾	ELITE	±0.35% of rate
	F-Series	±0.50% of rate
	H-Series	±0.50% of rate
	T-Series	±0.50% of rate
Repeatability⁽¹⁾	ELITE	±0.20% of rate
	F-Series	±0.25% of rate
	H-Series	±0.25% of rate
	T-Series	±0.25% of rate

(1) For details of flow accuracy and repeatability specifications, refer to the product data sheet for each sensor family. Because accuracies may vary for the D-Series sensors, refer to the product data sheet for further information.

Physical specifications

Weight	<ul style="list-style-type: none">• Transmitter with display: 11.5 lbs (5.2 kg)• Transmitter without display: 11.8 lbs (5.4 kg)
Housing	NEMA 4X (IP65) polyurethane-painted cast aluminum
Cable gland entrances	Three 3/4" – 14 NPT on transmitter base
Electric connections	<ul style="list-style-type: none">• Screw terminal blocks for all signal wiring can be unplugged• Fixed screw terminals for power connections• Screw terminal on housing for chassis ground• Screw terminals accept solid or stranded conductors, 0.14 to 2.5 mm² (16 to 26 AWG)
Mounting	May be remotely connected to any 9-wire Micro Motion sensor
Maximum cable lengths between sensor and transmitter⁽¹⁾	1000 ft (300 m)

(1) Micro Motion recommends using Micro Motion 9-wire cable. 10 ft (3 m) of Micro Motion 9-wire cable is included.

User interface

All models with or without display	<ul style="list-style-type: none">• User interface module can rotate 360° on the transmitter in 90° increments• Three-color status LED on user interface module indicates flowmeter condition at a glance, using a solid green, yellow, or red light. Zero in progress is indicated by a flashing yellow light.• Two clips for service port connections (requires removing transmitter housing cover and disconnecting the RS-485 connections, if connected)• Two clips for HART/Bell 202 connections (requires removing transmitter housing cover)• HART security switch (requires removing transmitter housing cover)
All models with display	<ul style="list-style-type: none">• Transmitter housing cover is metal with glass lens• User interface module includes LCD panel. LCD line 1 displays process variable; line 2 displays engineering unit of measure.• Display update rate is user-configurable: 1 to 10 seconds at 1-second increments• Display backlighting may be adjusted or turned off• Operator access to transmitter menus is provided via optical switches that are operated through the lens. LED indicators show when a "button" has been selected.
All models without display	<ul style="list-style-type: none">• Transmitter housing cover is all metal (no lens)• Access to user interface requires removing transmitter housing cover• Zero button allows flowmeter zero from field (requires removing transmitter housing cover)

Input/output signals

Sensor input	One 9-wire sensor signal input connection, intrinsically safe
Two mA outputs	<ul style="list-style-type: none">• Independently configure for mass flow, volume flow, density, concentration, temperature, pressure, or more• Not intrinsically safe• Internally powered• Can be selected as 4–20 mA or 0–20 mA current outputs• Galvanically isolated• Output is linear with process from 3.8 to 20.5 mA, per NAMUR NE43 when selected as 4–20 mA
One active or passive frequency/pulse output	<ul style="list-style-type: none">• Not intrinsically safe• Can report mass flow or volume flow, which can be used to indicate flow rate or total• Scalable to 10,000 Hz• Output is linear with flow rate to 12,500 Hz• Fault output at 15,000 Hz (upscale) or 0 Hz (downscale)• Power:<ul style="list-style-type: none">- Internal (Active): 0–15 V square wave, unloaded; internal 2.2 kΩ pull-up resistor to 15 V, galvanically isolated- External (Passive): Sinking capability: 0.1 A in “On” condition (0 V level), 30 VDC compliance in “Off” condition• Programmable pulse width for low frequencies
One active or passive discrete output	<ul style="list-style-type: none">• Not intrinsically safe• Can report five discrete events, flow switch, forward/reverse flow, calibration in progress, or fault• Power:<ul style="list-style-type: none">- Internal (active): digital level 0 to 15 V, with a 2.2 kΩ internal pull-up resistor, galvanically isolated- External (passive): +30 VDC maximum, +24 VDC typical• In passive (open collector) configuration: sinking capability is 0.1 A in “On” condition (0 V level), 30 VDC compliance in “Off” condition
One active discrete input	<ul style="list-style-type: none">• Not intrinsically safe• Internally powered configuration: +24 VDC, 10 mA maximum source current• Can reset all totals, reset mass total, reset volume total, start/stop totals, or start sensor zero
Communication	<ul style="list-style-type: none">• Bell 202 signal is superimposed on primary variable mA output and is available for host system interface; frequency 1.2 and 2.2 kHz, amplitude 0.8 V peak-to-peak, 1200 baud; requires 250 Ω to 1000 Ω load resistance• RS-485 signal is a 5 V square wave referenced to transmitter ground; physical layer is auto-detecting and supports baud rates from 1200 baud to 38.4 kilobaud
Sensor frequency output	For use with Micro Motion legacy peripheral devices <ul style="list-style-type: none">• 7.4 V peak-to-peak at sensor natural frequency, referenced to sensor ground• 10 kΩ output impedance
Sensor temperature output	For use with Micro Motion legacy peripheral devices, 5 mV/°C
mA input	The mA input can accept a signal from a temperature transmitter for external temperature measurement or pressure transmitter for pressure compensation of flow and density <ul style="list-style-type: none">• Range: 0–25 mA• Can be used to power independent temperature, pressure, or differential• Voltage sourcing capability: 15 V• Input impedance: 100 Ω

Power supply

Self switching

The internal power supply of the 9739 MVD transmitter is self switching between:

- 85 to 250 VAC⁽¹⁾, 48 to 62 Hz, 10 W typical, 15 W maximum
- 12 to 30 VDC⁽²⁾, 7 W typical, 14 W maximum

(1) Complies with low-voltage directive 2006/95/EC per EN 61010-1 (IEC 61010-1) with Amendment 2

(2) At startup, transmitter power source must provide a minimum of 1.6 A of short-term current at a minimum of 12 V at the transmitter's power input terminals

Environmental limits

Ambient temperature limits

°F

°C

Operating

–40 to +140

–40 to +60

Storage

–40 to +140

–40 to +60

Below –4 °F (–20 °C), the LCD responsiveness decreases and the LCD may become difficult to read. Above +131 °F (+55 °C), some darkening of the LCD panel may occur.

ATEX requires limiting the ambient temperature to below +131 °F (+55 °C).

Humidity limits

5 to 95% relative humidity, non-condensing at 140 °F (60 °C)

Vibration limits

Meets IEC 68.2.6, endurance sweep, 5 to 2000 Hz, 50 sweep cycles at 5.0 g

Environmental effects

EMI effects

Complies with EMC directive 2004/108/EC per EN 61326 Industrial

Complies with NAMUR NE-21: 2007

Ambient temperature effect

- On mA outputs: $\pm 0.005\%$ of span per °C
 - On temperature outputs: ± 0.01 °C of span per °C
 - On mA input: $\pm 0.01\%$ of span per °C
-

Hazardous area classifications

UL and CSA C-US

Ambient temperature is limited to below 140 °F (60 °C) for UL and CSA compliance.

Without display	Transmitter	Class I, Div. 1, Groups C and D. Class II, Div. 1, Groups E, F, and G explosion proof (when installed with approved conduit seals). Otherwise, Class I, Div. 2, Groups A, B, C, and D.
	Outputs	Provides nonincendive sensor outputs for use in Class I, Div. 2, Groups A, B, C, and D; or intrinsically safe sensor outputs for use in Class I, Div. 1, Groups C and D and Class II, Div. 1, Groups E, F, and G.
With display	Transmitter	Class I, Div. 2, Groups A, B, C, and D.
	Outputs	Provides nonincendive sensor outputs for use in Class I, Div. 2, Groups A, B, C, and D; or intrinsically safe sensor outputs for use in Class I, Div. 1, Groups C and D and Class II, Div. 1, Groups E, F, and G.

ATEX

ATEX ambient temperature range is from –22 °F to 131 °F (–30 °C to +55 °C) without routine testing, and –40 °F to 131 °F (–40 °C to +55 °C) with routine testing.

Without display	Flameproof transmitter	II 2G Ex d [ib] IIB/IIC T6 Gb
	Safe-area transmitter	II (2)G [Ex ib Gb] IIB/IIC
With display		II (2)G [Ex ib Gb] IIB/IIC

IECEX

IECEX ambient temperature range is from –22 °F to 131 °F (–30 °C to +55 °C) without routine testing, and –40 °F to 131 °F (–40 °C to +55 °C) with routine testing.

Without display	Flameproof transmitter	Ex d [ib] IIB/IIC T6 Gb
	Safe-area transmitter	[Ex ib Gb] IIB/IIC
With display		[Ex ib Gb] IIB/IIC

Dimensions

Front and side views

Dimensions in inches (mm)

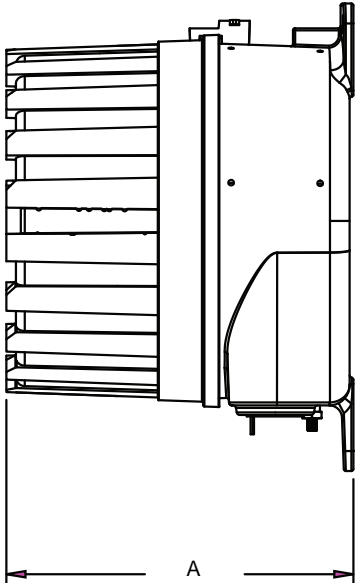
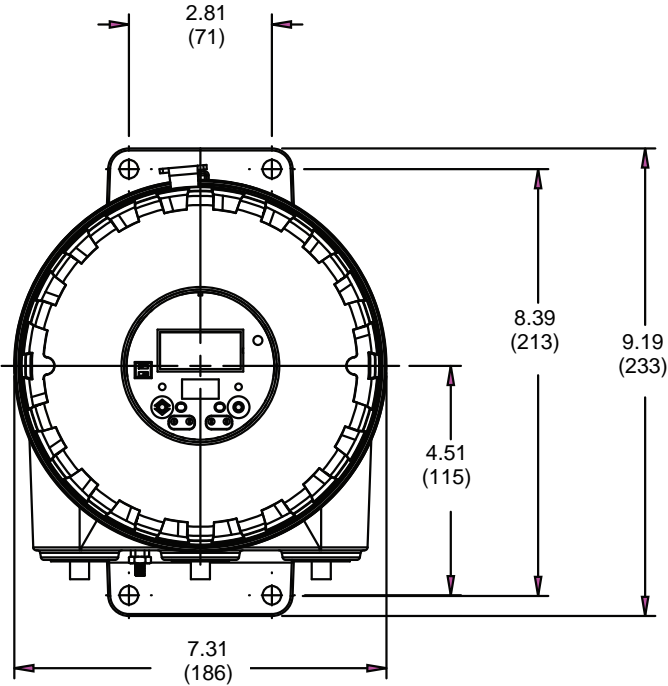

A: With display: 6.82 (173)
Without display: 7.28 (185)

Bottom view

Dimensions in inches (mm)

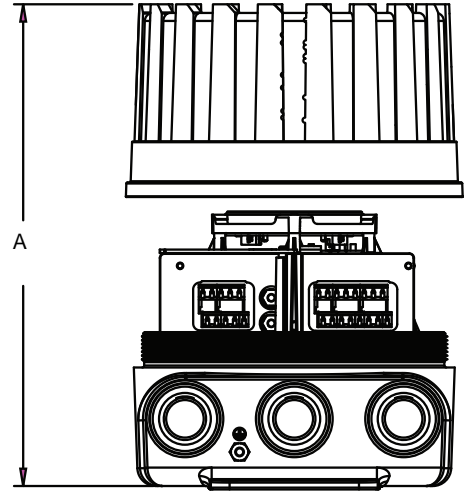
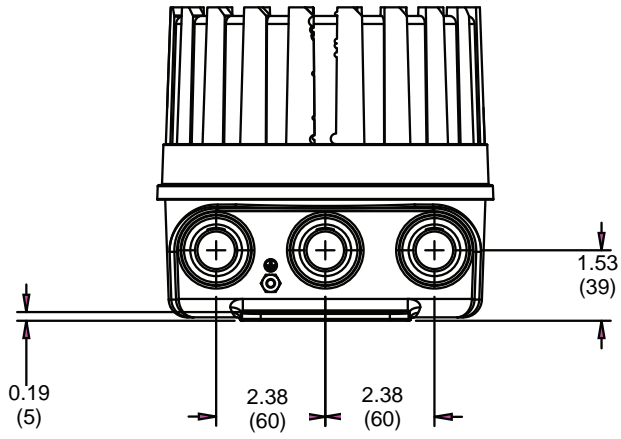

A: With display: 10.46 (266)
Without display: 11.50 (292)

Ordering information: 9739 MVD transmitter

Model	Product description
9739MVD	Micro Motion Coriolis multivariable transmitter
Code	Power
6	12 to 30 VDC or 85 to 265 VAC; self switching
Code	Display
1 ⁽¹⁾	Dual line display for process variables and totalizer reset
3	No display
Code	Approvals
For display code 1 (with display)	
M	Micro Motion Standard (no approval)
U	UL (Class 1 Div. 2)
2	CSA-US and Canada (Class 1 Div. 2)
Y	ATEX intrinsically safe sensor outputs; Safe area II (2) G
For display code 3 (no display)	
M	Micro Motion Standard (no approval)
U	UL (Class 1 Div. 1)
A	CSA-US and Canada (Class 1 Div. 1)
Y	ATEX intrinsically safe sensor outputs; Safe area II (2) G
W	ATEX intrinsically safe sensor outputs; flameproof transmitter II 2 G
J	Hardware ready for TIIS approval (EPM Japan only)
S	TIIS - IIB sensor (Not available for quote outside of Japan)
T	TIIS - IIC sensor (Not available for quote outside of Japan)
Code	Conduit connections
For approval code M (MMI standard)	
A	No fittings or glands
B	1 gland; nickel-plated brass
C	3 glands; nickel-plated brass
For approval code U (UL)	
A ⁽²⁾	No fittings or glands
J	1 explosion-proof seal fitting
K	3 explosion-proof seal fittings
For approval codes 2 & A (CSA-US and Canada)	
A	No fittings or glands
J	1 explosion-proof seal fitting
K	3 explosion-proof seal fittings
For approval code Y (ATEX Intrinsically Safe sensor outputs)	
A	No fittings or glands
B	1 gland; nickel-plated brass
Q	1 gland; stainless steel
C	3 glands; nickel-plated brass
W	3 glands; stainless steel
Continued on next page	

(1) Transmitter is not flameproof when supplied with display code 1

(2) Not valid with display code 3

Ordering information: 9739 MVD transmitter *continued*

Code	Conduit connections
For approval code W (ATEX)	
A	No fittings or glands
D	1 gland; nickel-plated brass
E	1 gland; stainless steel
F	3 glands; nickel-plated brass
G	3 glands; stainless steel
For approval code S and T (TIIS)	
Y	Japan - 3 glands, 3/4 NPT stainless steel
For approval code J (Hardware ready for TIIS approval)	
A	No fittings or glands
Code	Language
A	Danish CE requirements document; English installation and configuration manual
D	Dutch CE requirements document; English installation and configuration manual
E	English CE requirements document; English installation and configuration manuals
F	French installation manual; English configuration manual
G	German installation manual; English configuration manual
H	Finnish CE requirements document; English installation and configuration manual
I	Italian CE requirements document; English installation and configuration manual
J	Japanese installation manual; English configuration manual
M	Chinese installation manual; English configuration manual
N	Norwegian CE requirements document; English installation and configuration manual
O	Polish CE requirements document; English installation and configuration manual
P	Portuguese CE requirements document; English installation and configuration manual
S	Spanish installation manual; English configuration manual
W	Swedish CE requirements document; English installation and configuration manual
C	Czech CE requirements document; English installation and configuration manual
B	Hungarian CE requirements document; English installation and configuration manuals
K	Slovak CE requirements document; English installation and configuration manuals
U	Greek CE requirements document; English installation and configuration manuals
L	Latvian CE requirements document; English installation and configuration manuals
V	Lithuanian CE requirements document; English installation and configuration manuals
Y	Slovenian CE requirements document; English installation and configuration manuals
Code	Software options 1
Z	Flow and density variables (standard)
G	Concentration measurement
A	Petroleum measurement
X ⁽¹⁾	ETO software option 1
Code	Software options 2
Z	No software options 2
X ⁽¹⁾	ETO software option 1

(1) Available only with factory option X

Ordering information: 9739 MVD transmitter *continued*

Code	Factory options
Z	Standard product
X	ETO product
R	Restocked product (if available)
Code	Add on Options (optional)
PK	2-inch Pipe Mount U-Bolt Kit for electronics
Typical Model Number: 9739MVD 6 1 2 A E Z Z Z	

Ordering information: 9739 MVD retrofit kit













Model	Product description
RETRO9739BLNDN	Retrofit Kit, 9739 MVD without display (Non-ATEX)
RETRO9739BLNDNA	Retrofit Kit, 9739 MVD without display (Non-ATEX) with Petroleum Measurement
RETRO9739BLNDNG	Retrofit Kit, 9739 MVD without display (Non-ATEX) with Concentration Measurement
RETRO9739BLNDW	Retrofit Kit, 9739 MVD without display (ATEX Flameproof)
RETRO9739BLNDWA	Retrofit Kit, 9739 MVD without display (ATEX Flameproof) with Petroleum Measurement
RETRO9739BLNDWG	Retrofit Kit, 9739 MVD without display (ATEX Flameproof) with Concentration Measurement
RETRO9739BLNDY	Retrofit Kit, 9739 MVD without display (ATEX Safe Area)
RETRO9739BLNDYA	Retrofit Kit, 9739 MVD without display (ATEX Safe Area) with Petroleum Measurement
RETRO9739BLNDYG	Retrofit Kit, 9739 MVD without display (ATEX Safe Area) with Concentration Measurement
RETRO9739DISPN	Retrofit Kit, 9739 MVD with display (Non-ATEX)
RETRO9739DISPNA	Retrofit Kit, 9739 MVD with display (Non-ATEX) with Petroleum Measurement
RETRO9739DISPNG	Retrofit Kit, 9739 MVD with display (Non-ATEX) with Concentration Measurement
RETRO9739DISPY	Retrofit Kit, 9739 MVD with display (ATEX Safe Area)
RETRO9739DISPYA	Retrofit Kit, 9739 MVD with display (ATEX Safe Area) with Petroleum Measurement
RETRO9739DISPYG	Retrofit Kit, 9739 MVD with display (ATEX Safe Area) with Concentration Measurement



HA HIGH ACCURACY

measurement instruments

Our offering:

	<p>Pressure Measurement</p>		<p>Level Measurement</p>
	<p>Temperature Measurement</p>		<p>Flow Measurement</p>
	<p>Marine Measurement & Analytical</p>		<p>Gas Analysis</p>
	<p>Liquid Analysis</p>		<p>Flame and Gas Detection</p>
	<p>Tank Gauging</p>		<p>Wireless Infrastructure</p>
	<p>Acoustic & Discrete</p>		

www.high-accuracy.com

**Emerson Process Management
Americas**

7070 Winchester Circle
Boulder, Colorado USA 80301

www.MicroMotion.com
www.Rosemount.com

I: +1 800 522 6277
T: +1 (303) 527 5200
F: +1 (303) 530 8459

Mexico T: 52 55 5809 5300
Argentina T: 54 11 4837 7000
Brazil T: 55 15 3413 8000
Venezuela T: 58 26 1300 8100

**Emerson Process Management
Europe/Middle East**

Central & Eastern Europe T: +41 41 7686 111
Dubai T: +971 4 811 8100
Abu Dhabi T: +971 2 697 2000
France T: 0800 917 901
Germany T: 0800 182 5347
Italy T: 8008 77334
The Netherlands T: +31 318 495 555
Belgium T: +32 2 716 77 11
Spain T: +34 913 586 000
U.K. T: 0870 240 1978
Russia/CIS T: +7 495 981 9811

**Emerson Process Management
Asia Pacific**

Australia T: (61) 3 9721 0200
China T: (86) 21 2892 9000
India T: (91) 22 6662 0566
Japan T: (81) 3 5769 6803
South Korea T: (82) 2 3438 4600
Singapore T: (65) 6 777 8211

© 2014 Micro Motion, Inc. All rights reserved.

The Emerson logo is a trademark and service mark of Emerson Electric Co. Micro Motion, ELITE, ProLink, MVD and MVD Direct Connect marks are marks of one of the Emerson Process Management family of companies. All other marks are property of their respective owners.

Micro Motion supplies this publication for informational purposes only. While every effort has been made to ensure accuracy, this publication is not intended to make performance claims or process recommendations. Micro Motion does not warrant, guarantee, or assume any legal liability for the accuracy, completeness, timeliness, reliability, or usefulness of any information, product, or process described herein. We reserve the right to modify or improve the designs or specifications of our products at any time without notice. For actual product information and recommendations, please contact your local Micro Motion representative.

