



**HIGH ACCURACY**

m e a s u r e m e n t i n s t r u m e n t s

## PRODUCT DATASHEET

[www.high-accuracy.com](http://www.high-accuracy.com)

# Fisher™ 2100 Pneumatic and 2100E Electric Liquid Level Switches

Fisher 2100 on-off pneumatic switch and 2100E electric switch sense (shown in figure 1) high or low liquid levels. Typically, these switches pneumatically or electrically operate safety shutdown systems for field processing equipment in oil and gas production applications. 2100 and 2100E switches both use a displacer-style sensor located in an external cage that mounts on the outside of a vessel.

Unless otherwise noted, all NACE references are to NACE MR0175-2002.

## Features

- **Proven Rugged Construction**—The switch is isolated and sealed from the process through a corrosion-resistant displacer and torque tube assembly for maximum reliability. The displacer can withstand up to 1-1/2 times the maximum working pressure, allowing it to remain in the cage during hydrostatic testing.
- **Sour Service Capability**—Materials are available for applications handling sour fluids and gases. These constructions comply with the metallurgical requirements of NACE MR0175-2002. Environmental restrictions may apply.
- **Application Versatility**—The 2100 and 2100E switch construction comes in a left-hand as well as a right-hand mounting version. The explosion-proof, hermetically sealed 2100E switch is offered as both a factory mounting and as an electric switch retrofit to the proven 2100 switch.
- **Installation Versatility**—The displacer cage has two 1 NPT pipe plugs that you can remove and relocate for horizontal instead of vertical equalizing piping, or for installation of a bleed or drain valve.
- **Easy Reversibility**—Switching action for both the 2100 and 2100E switches is field-reversible from high-level to low-level or vice versa without additional parts.



FISHER 2100 PNEUMATIC LIQUID LEVEL SWITCH

**Specifications**

**Input Signal**

Liquid level

**Minimum Process Liquid Specific Gravity**

0.5 (consult your [Emerson sales office](#) or Local Business Partner for specific gravities below this value)

**Output Signal**

2100: Equal to the supply pressure when the switch is in the normal position (flapper against nozzle) and reduced to approximately atmospheric pressure, depending upon the bleed orifice size and the piping configuration, when the switch is activated  
2100E: Same as supply signal

**Supply Signal**

2100: ■ 2.1 to 4.1 bar (30 to 60 psig), ■ 4.1 to 6.9 bar (60 to 100 psig) or ■ 6.9 to 10.3 bar (100 to 150 psig)  
2100E: 11 amperes, 1/4 horsepower at 125/250 volts ac; 5 amperes resistive, 3 amperes inductive at 28 volts DC

**Supply Medium (2100)**

Air or Natural Gas

**Steady-State Air Consumption<sup>(1)</sup> (2100)**

Less than 0.03 normal m<sup>3</sup>/hour (1.0 scfh) for all supply pressures when the liquid level is 25.4 mm (1 inch) below the normal switch position (flapper against nozzle) for high-level switching or 25.4 mm (1 inch) above the normal switch position for low-level switching

**Maximum Working Pressure<sup>(2)</sup>**

■ 153 bar (2220 psig) WOG<sup>(3)</sup> except ■ 24 bar (350 psig) WOG is the maximum working pressure for sight window construction

**Operative Temperature Range<sup>(2)</sup>**

2100: -29 to 204°C (-20 to 400°F)  
2100E: -29 to 82°C (-20 to 180°F)

**Displacer Diameter**

102 mm (4 inches)

**Process Connection Size**

153 bar (2220 psig) WOG<sup>(3)</sup>: ■ 1 NPT internal  
■ DN 50 (NPS 2) Schedule 80 buttwelding ends, or  
■ DN 50 (NPS 2) Schedule 160 buttwelding ends

**2100 Switch Supply Pressure Connection Size**

1/4 NPT internal

**2100E Switch Electrical Connection Size**

1/2 NPT external

**Hazardous Area Classification for 2100 Switch**

The 2100 pneumatic switch complies with the requirements of ATEX Group II Category 2 Gas and Dust

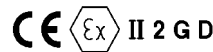

The 2100 pneumatic switch meets Customs Union technical regulation TP TC 012/2011 for Groups II/III Category 2 equipment

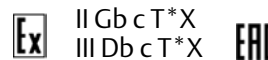

**Hazardous Area Classification for 2100E Switch**

Approvals on the electrical switch component in the 2100E, supplied by ITT NEO-DYN are as follows:

CSA— Class I Division 1, Groups A,B,C,D  
Class II Division 1, Groups E,F,G ; Dual Seal

FM— XP - Class I Division 1 Groups A,B,C,D  
DIP - Class II Division 1 Groups E,F,G

UL— Class I Division 1 Groups A,B,C,D  
Class II Division 1 Groups E,F,G

ATEX— Ex d IIC, Ex tb IIIC

IECEx— Ex d IIC, Ex tb IIIC

Approvals on the complete 2100E assembly are as follows:

CUTR— Customs Union (Russia, Belarus, Kazakhstan and Armenia), 1Ex d IIC

Contact your Emerson sales office or Local Business Partner if additional information is required.

## Specifications (continued)

### Construction Materials

**Cage:** ■ SA216 Cast Steel (WCC), ■ SA216 Cast Steel (WCC) (NACE MR0175-2002) and ■ SA351 316 SST (CF8M)

**Displacer:** ■ S30400 stainless steel (standard)  
■ S31603 solution annealed stainless steel (NACE MR0175-2002)

**Torque Rod & Tube Assembly:** N05500

**Bearing:** Glass-filled PTFE

**O-Rings:** Fluorocarbon

**Cover Gasket:**

2100: Chloroprene

2100E: Silicone rubber

**Other Gaskets:** Silicone rubber

**Nozzle Block Assembly (2100 only):** Aluminum & stainless steel

**Nozzle (2100 only):** Stainless steel

**Flapper & Clamp Assembly (2100 only):** Stainless steel

**Flapper Seat (2100 only):** Fluorocarbon

**Magnet (2100 only):** Special material

**Body Block:** Steel

**Cover:**

2100: Clear plastic

2100E: Aluminum

**Housing (2100E only):** Aluminum

**Other Metal Parts:** Stainless steel

### Options

**2100 Switch Option:** Individual street tee and bleed orifice (when it is not desired to supply several level switches from one common block and bleed restriction)

**Sight Window Option:** A sight window is available for either the 2100 or 2100E that installs in place of the pipe plug, as illustrated in figure 1.

**NACE Option:** Constructions are available which comply with the metallurgical requirements of NACE MR0175-2002. Environmental restriction may apply.

### Shipping Weights

17.2 kg (38 pounds)

NOTE: Specialized instrument terms are defined in ANSI/ISA Standard 51.1 - Process Instrument Terminology.

1. Normal m<sup>3</sup>/h--normal cubic meters per hour at 0°C, 1.01325 bar, absolute (Scfh--standard cubic feet per hour at 60°F, 14.7 psia)

2. Pressure and temperature limits in this document and any applicable standards or code limitations should not be exceeded.

3. Water, Oil, Gas maximum working pressure. Corresponds to Cold Working Pressure: the maximum pressure rating allowed under normal ambient temperature conditions, which are usually understood to be -29 to 38°C (-20 to 100°F). Refer to MSS SP-25.

Figure 1. Fisher 2100E Electric Liquid Level Switch

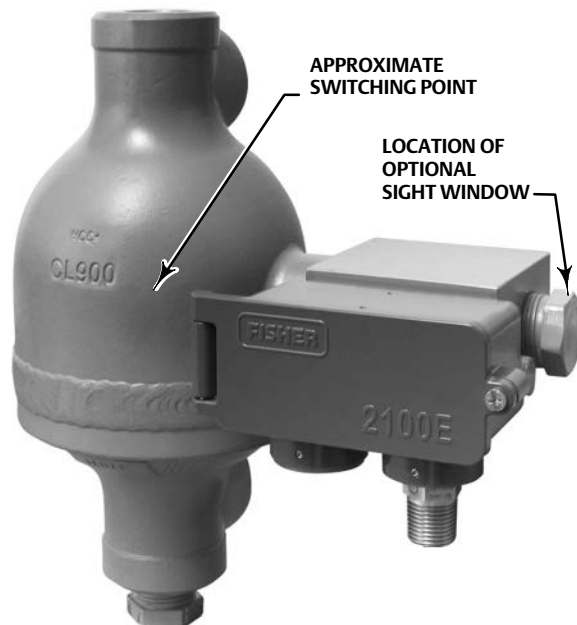

X0682

## Principle of Operation

Figure 2 shows the 2100 switch with the nozzle, flapper, and magnet positioned for high level activation. When the switch is in the normal position with the flapper against the nozzle, output pressure cannot bleed off and remains the same as full supply pressure. Rising liquid level exerts a buoyant force on the displacer, producing a torque on the torque tube. When the torque transmitted by the torque tube exceeds the torque exerted on the flapper by the magnet, the flapper snaps away from the nozzle, allowing output pressure to bleed through the nozzle faster than supply pressure can enter through the bleed orifice. The reduced pressure in the output signal line activates the shutdown or alarm system. When the liquid level lowers, the falling displacer forces the flapper into the field of the magnet, letting the magnet snap the flapper against the nozzle and causing output pressure to build to full supply pressure.

Figure 2. Principle of Operation for High-Level Fisher 2100 Switch

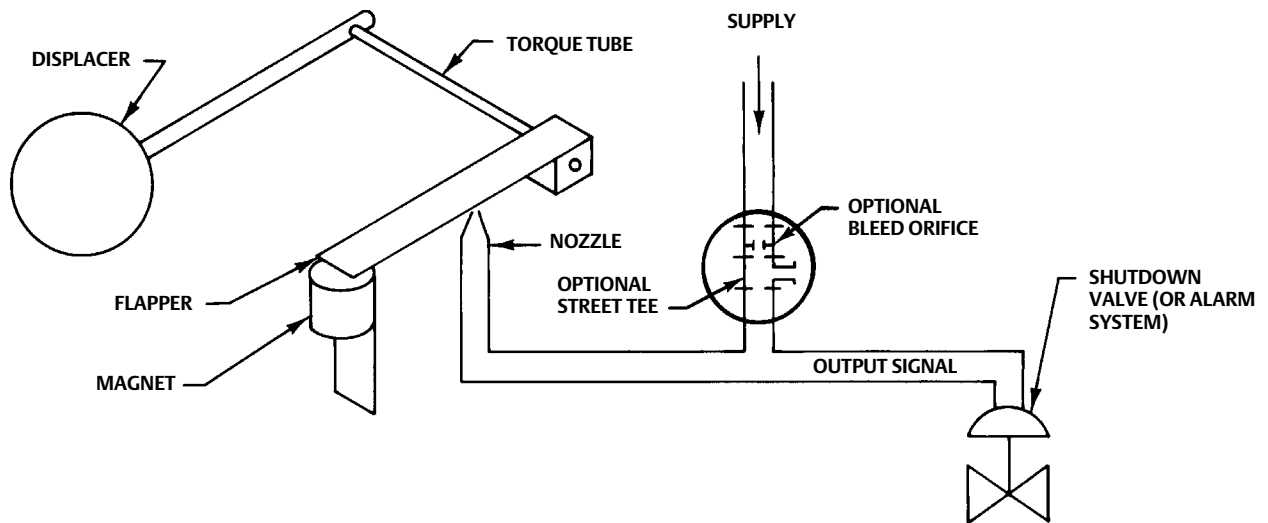

A3619-2

Figure 3. Construction Details of Low-Level Fisher 2100 Switch

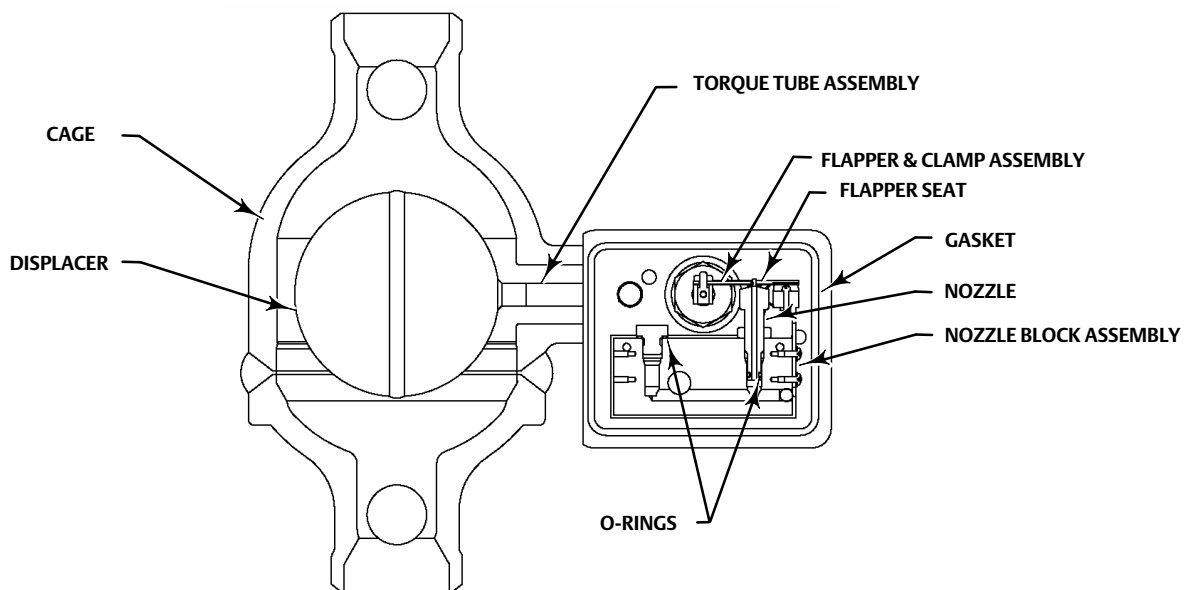

GE59150

Figure 4. Construction Details of Fisher 2100E Switch

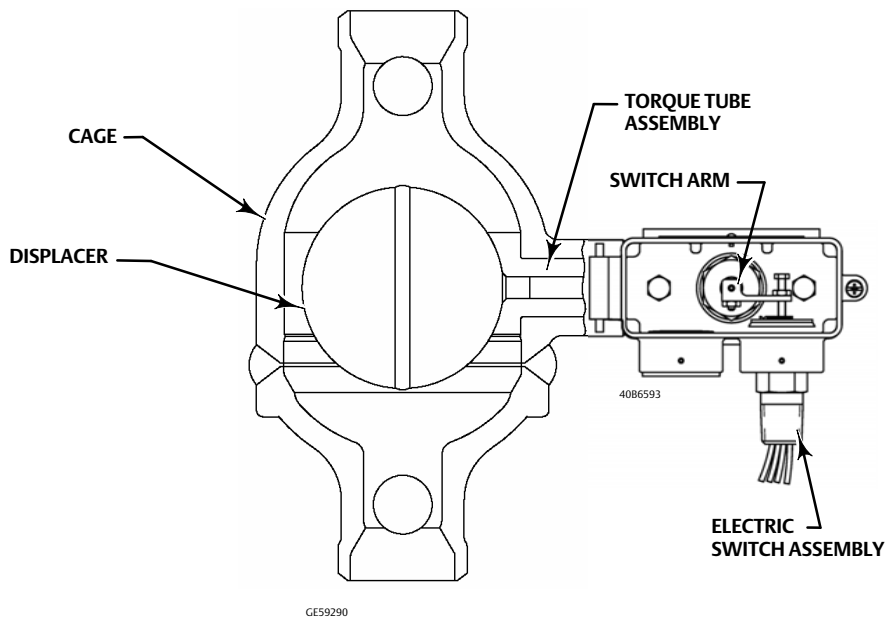

Figure 3 shows a sectional view of the 2100 switch positioned for low level activation. The nozzle, flapper, and magnet are on the opposite side of the torque tube, so that downward displacer travel moves the flapper away from the nozzle.

With the 2100E switch (figure 4), rising liquid level exerts a buoyant force on the torque tube that either activates or deactivates an electrical SPDT or DPDT switch depending on the switching action desired. Falling liquid level deactivates or activates the same switch depending on the action desired.

## Installation

The forged-in horizontal line on a 2100 or 2100E displacer cage indicates the approximate switching point. When mounted, the 2100 or 2100E switch is positioned so that the horizontal line corresponds to the level at which switching is desired. Isolating valves should be installed in the equalizing piping between the tank and the cage. Dimensions are shown in figure 5 and table 1.

## Ordering Information

### Application

When ordering, specify:

- Supply pressure (2100 switch only)
- SPDT or DPDT switch construction (2100E switch only)
- Maximum working pressure and temperature
- Switching action for high or low level alarming

### Construction

Refer to the specifications. Review the information under each specification and in the referenced figures; specify the desired selection whenever there is a choice to be made. High level switching and right-hand mounting will be supplied automatically unless otherwise specified. Always specify the complete type number of the desired equipment.

Figure 5. Dimensions (also see table 1)

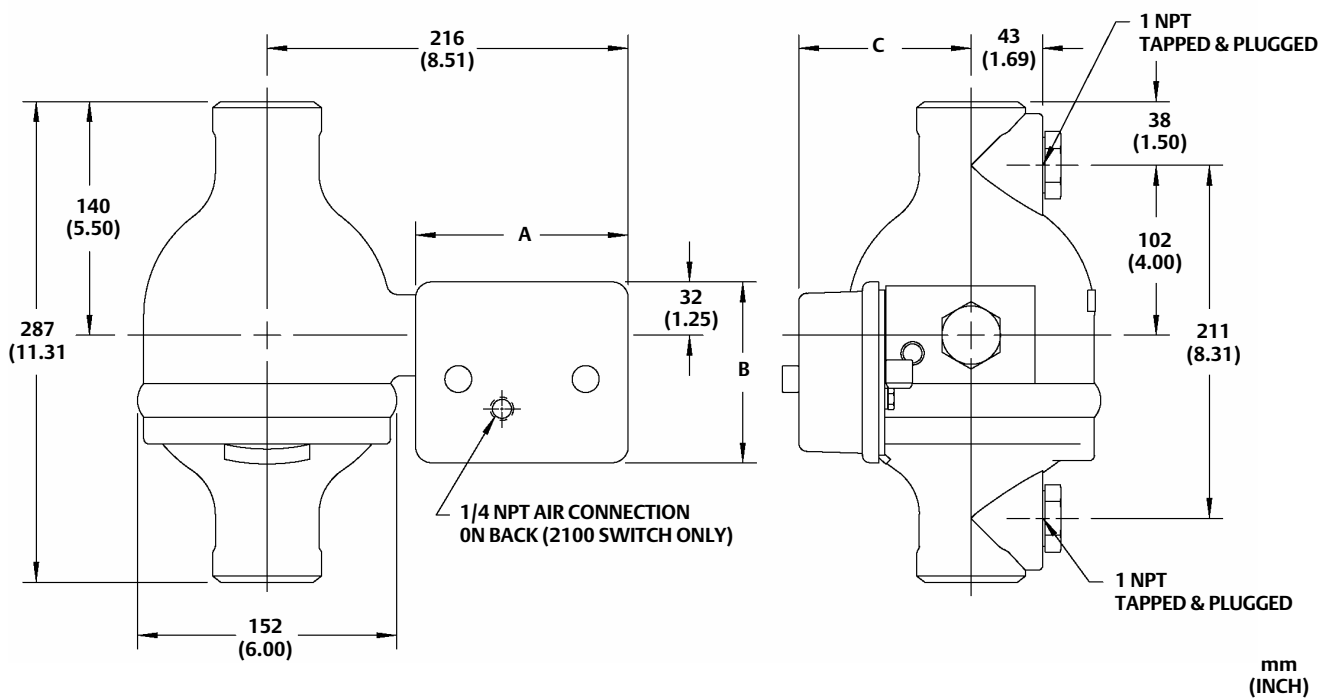

GE59300

Table 1. Dimensions

TYPE	DIMENSIONS					
	mm			Inches		
	A	B	C	A	B	C
2100	127	108	103	5.00	4.25	4.06
2100E	130	57	111	5.12	2.25	4.38











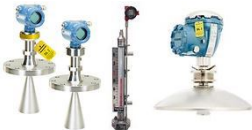



# HIGH ACCURACY

measurement instruments

Our offering:

	<p>Pressure Measurement</p>		<p>Level Measurement</p>
	<p>Temperature Measurement</p>		<p>Flow Measurement</p>
	<p>Marine Measurement &amp; Analytical</p>		<p>Gas Analysis</p>
	<p>Liquid Analysis</p>		<p>Flame and Gas Detection</p>
	<p>Tank Gauging</p>		<p>Wireless Infrastructure</p>
	<p>Acoustic &amp; Discrete</p>		

[www.high-accuracy.com](http://www.high-accuracy.com)

Neither Emerson, Emerson Automation Solutions, nor any of their affiliated entities assumes responsibility for the selection, use or maintenance of any product. Responsibility for proper selection, use, and maintenance of any product remains solely with the purchaser and end user.

Fisher is a mark owned by one of the companies in the Emerson Automation Solutions business unit of Emerson Electric Co. Emerson Automation Solutions, Emerson, and the Emerson logo are trademarks and service marks of Emerson Electric Co. All other marks are the property of their respective owners.

The contents of this publication are presented for informational purposes only, and while every effort has been made to ensure their accuracy, they are not to be construed as warranties or guarantees, express or implied, regarding the products or services described herein or their use or applicability. All sales are governed by our terms and conditions, which are available upon request. We reserve the right to modify or improve the designs or specifications of such products at any time without notice.

Emerson Automation Solutions  
Marshalltown, Iowa 50158 USA  
Sorocaba, 18087 Brazil  
Cernay, 68700 France  
Dubai, United Arab Emirates  
Singapore 128461 Singapore

[www.Fisher.com](http://www.Fisher.com)

