



**HIGH ACCURACY**

m e a s u r e m e n t i n s t r u m e n t s

## PRODUCT DATASHEET

[www.high-accuracy.com](http://www.high-accuracy.com)

# Rosemount™ 928 Wireless Gas Monitor

## Integrated Wireless Gas Monitoring



**The Rosemount 928 Wireless Gas Monitor is the first integrated WirelessHART® toxic gas monitoring solution with a tool-less hot-swappable sensor from Emerson™. The Rosemount 928 Wireless Gas Monitor extends detection coverage to remote installations, eliminates wiring costs, and reduces installation and commissioning times.**

- Hot-swappable electrochemical sensor module with end-of-life diagnostics can be installed in the field without tools.
- Hazardous location, performance, and functional safety approvals for worldwide use.
- Large liquid crystal display clearly shows gas concentration and transmitter diagnostics.
- Optional discrete output for activating field alarms.

# Features

## WirelessHART communication

Traditional hydrogen sulfide electrochemical sensor technology is proven and reliable, but conventional products require a wired infrastructure for power and signal communication. The 928 requires no wired infrastructure and dramatically reduces installation and maintenance costs.

## Hot-swappable power module

The device uses a replaceable, intrinsically safe lithium-thionyl chloride power module. The power module has over three years of service life<sup>(1)</sup> and can be easily exchanged in the field in hazardous locations.

## High performance monitoring

The Rosemount 928 Wireless Gas Monitor has comparable performance to conventional wired gas monitors. The device has an accuracy of ±3 ppm or 10 percent of reading, whichever is greater. Sensor response time is less than 10 seconds for T50 and less than 45 seconds for T90.

## Hot-swappable sensor module

The Rosemount 928 Wireless Gas Monitor uses the Rosemount 628 Series of hot-swappable electrochemical Gas Sensor Modules that can be installed in the field with one hand and no tools.

The Rosemount 628 Gas Sensor Module is a smart sensor. As such, it retains its own calibration information. It must be connected to a Rosemount 928 Transmitter to perform calibration, but the calibration settings are stored in the sensor itself rather than in the Rosemount 928 Transmitter. The Rosemount 628 Gas Sensor Module may be uninstalled from a Rosemount 928 Transmitter and reinstalled in another without affecting its calibration.

The sensor is automatically recognized by the device. Built-in end-of-life diagnostics alert you when sensor replacement is necessary.

## Built for Harsh Environments

The Rosemount 928 Wireless Gas Monitor is designed to operate in ambient temperatures ranging from -40 °C to +50 °C (-40 °F to +122 °F). Ingress protection levels of IP66 are achieved with the ingress protection (IP) filter fitted to the Rosemount 628 Gas Sensor Module.

---

1. Power module service life depends on wireless update rate, local display settings, and ambient conditions.

---

## Contents

Features .....	2	Product Certifications .....	6
Ordering Information .....	3	Dimensional Drawings .....	8
Specifications .....	4		

## Ordering Information

**Table 1. Rosemount 928 Wireless Gas Monitor Product Ordering Information**

The starred offerings (★) represent the most common options and should be selected for best delivery. The non-starred offerings are subject to additional delivery lead time.

Model	Product description	
928	Standard Wireless Gas Monitor	★
<b>Transmitter output</b>		
X	Wireless	★
<b>Sensor options</b>		
SS	Sensor specified separately and shipped with the transmitter (requires specification of 628 model)	★
UT	Universal Transmitter (no sensor specified)	★
<b>Discrete output</b>		
00	No discrete output; wireless communication only	★
01	Discrete output and wireless communication	★
<b>Housing material</b>		
2A	Aluminum, 1/2- 14 NPT conduit	★
2S	Stainless steel, 1/2- 14 NPT conduit	★
<b>Product certifications</b>		
I5	U.S.A. Intrinsically Safe	★
I6	Canada Intrinsically Safe	★

### Wireless options

<b>Wireless update range, operating frequency, and protocol</b>		
WA3	User configurable update rate, 2.4 GHz DSSS, IEC 62591 (WirelessHART)	★
<b>Wireless update range, operating frequency, and protocol</b>		
WK1	External antenna, adapter for black power module (I.S. power module sold separately)	★
WM1	Extended range, external antenna	★
WJ1	Remote antenna, adapter for black power module (I.S. power module sold separately)	★
WN1	High-gain remote antenna, adapter for black power module (I.S. power module sold separately)	★

### Other options

<b>Mounting bracket</b>		
B4	Universal L mounting bracket for 2-inch pipe mounting; SST bracket and bolts	★
<b>Configuration</b>		
C1	Factory configuration date, descriptor, message fields, and wireless parameters	★

**Table 1. Rosemount 928 Wireless Gas Monitor Product Ordering Information**

The starred offerings (★) represent the most common options and should be selected for best delivery. The non-starred offerings are subject to additional delivery lead time.

Quality documentation		
Q1	Certificate of Compliance	★
Typical model number: 928 X SS 00 2A I5 WA3 WK1 B4		

**Table 2. Rosemount 628 Gas Sensor Module Ordering Information**

The starred offerings (★) represent the most common options and should be selected for best delivery. The non-starred offerings are subject to additional delivery lead time.

Model	Product description	
628	Rosemount 628 Gas Sensor Module	
Sensor technology		
EC	Electrochemical	★
Gas type		
T02	Hydrogen Sulfide (H <sub>2</sub> S)	★
Unit of measurement		
2	ppm	★
Range		
F	0–100	★
Typical model number: 628 EC T02 2 F		

**Table 3. Spare Parts Ordering Information**

Description	Spare part number
Ingress Protection Filter	00628-9000-0001

# Specifications

## Functional specifications

### Measurement type

Gas Concentration Level 0–100 ppm range for Hydrogen Sulfide (H<sub>2</sub>S)

### Sensor type

Tool-less hot-swappable electrochemical cell module

### Outputs

IEC 62591 WirelessHART 2.4GHz DSSS

Optional discrete output to support local alarms

### Communication protocol

IEC 62591 WirelessHART 2.4GHz DSSS with user-configurable update rate

### Humidity limits

0–100% relative humidity

### Diagnostics

End-of-life sensor diagnostic

### Accuracy

± 3 ppm or 10% of reading, whichever is greater

### Response time

T<sub>20</sub> < 8 seconds

T<sub>50</sub> < 10 seconds

T<sub>90</sub> < 45 seconds

## Physical specifications

### Wireless power module

Replaceable, intrinsically safe lithium-thionyl chloride power module.

### Materials of construction

#### Housing

Low copper aluminum (A360) or stainless steel

#### Antenna

PBT/PC integrated omnidirectional antenna

### Environmental

Operating temperature: -40 °C to +50 °C (-40 °F to +122 °F)

Ingress protection: IP66 ingress protection (IP) filter

## Performance specifications

### Wireless transmission rate

User selectable from 1 second to 60 minutes

# Product Certifications

Rev 1.0

## European Union Directive information USA

A copy of the EC Declaration of Conformity can be found at the end of the Quick Start Guide. The most recent revision of the EC Declaration of Conformity can be found at [Emerson.com/Rosemount](http://Emerson.com/Rosemount).

### Telecommunication compliance

All wireless devices require certification to ensure that they adhere to regulations regarding the use of the RF spectrum. Nearly every country requires this type of product certification. Emerson is working with governmental agencies around the world to supply fully compliant products and remove the risk of violating country directives or laws governing wireless device usage.

### FCC and IC

This device complies with Part 15 of the FCC Rules. Operation is subject to the following conditions: This device may not cause harmful interference. This device must accept any interference received, including interference that may cause undesired operation. This device must be installed to ensure a minimum antenna separation distance of 20 cm from all persons.

### Ordinary location certification

The transmitter has been examined and tested to determine that the design meets basic electrical, mechanical, and fire protection requirements by CSA and FM Approvals, each a nationally recognized testing laboratory (NRTL) as accredited by the Federal Occupational Safety and Health Administration (OSHA).

### Installing in North America

The US National Electrical Code® (NEC) and the Canadian Electrical Code (CEC) permit the use of Division-marked equipment in Zones and Zone-marked equipment in Divisions. The markings must be suitable for the area classification, gas, and temperature class. This information is clearly defined in the respective codes.

- I5** U.S.A Intrinsically Safe (IS)  
 Certificate: CSA 70138122  
 Standards: FM 3600–2011, FM 3610–2010, UL Standard 50–11th edition, UL 61010–1–3rd edition, ANSI/ISA–60079–0 (12.00.01)–2013, ANSI/ISA–60079–11 (12.02.01)–2013  
 Markings: IS CL I, DIV 1, GP A, B, C, D, T4;  
 Class 1, Zone 0, AEx ia IIC T4 Ga;  
 T4 (-40 °C ≤ Ta ≤ +50 °C) when installed according to Rosemount drawing 00928-1010;  
 Type 4X

#### Special Conditions for Safe Use (X):

1. The power module may be replaced in a hazardous area. The power module has a surface resistivity greater than 1 Gigaohm. Care must be taken during transportation to and from the point of installation to prevent electrostatic charge and buildup.
2. The surface resistivity of the antenna is greater than 1 Gigaohm. To avoid electrostatic charge buildup, it must not be rubbed or cleaned with solvents or a dry cloth.
3. Substitution of components may impair intrinsic safety.

Alarm Circuit Terminal Input/Output Parameters
$V_{max}/U_i = V_{oc}/U_o = 28V$
$I_{max}/I_i = I_{sc}/I_o = 93.3mA$
$P_{max}/P_i = P_{max}/P_o = 653mW$
$C_i = 5.72nF$
$L_i = 0mH$

## Canada

- I6** Canada Intrinsically Safe  
 Certificate: CSA 70138122  
 Standards: CAN/CSA C22 No. 0–10 C22.2 No. 94-M91, CSA Std C22.2 No. 142-1987, CAN/CSA-60079-0–2011, CAN/CSA-60079-11–2014, CAN/CSA-61010-1–2012  
 Markings: IS CL I, DIV 1, GP A, B, C, D, T4;  
 Ex ia IIC T4 Ga;  
 T4 (-40 °C ≤ Ta ≤ +50 °C) when installed according to Rosemount drawing 00928-1010;  
 Type 4X

**Special Conditions for Safe Use (X):**

1. For use only with the Emerson Model 701PBKKF, the Computation Systems, Inc MHM-89004, or the Perpetuum Ltd. IPM71008/IPM74001.  
Pour utilisation uniquement avec Emerson Model 701PBKKF, Computation Systems, Inc MHM-89004, ou Perpetuum Ltd. IPM71008/IPM7400
2. The surface resistivity of the antenna is greater than 1 GΩ.  
To avoid electrostatic charge build-up, it must not be rubbed or cleaned with solvents or a dry cloth.  
La résistivité de surface du boîtier est supérieure à un gigaohm. Pour éviter l'accumulation de charge électrostatique, ne pas frotter ou nettoyer avec des produits solvants ou un chiffon sec.
3. Substitution of Components may Impair Intrinsic Safety  
La substitution de composants peut compromettre la sécurité intrinsèque.

# Dimensional Drawings

Figure 1. Dimensional Drawing

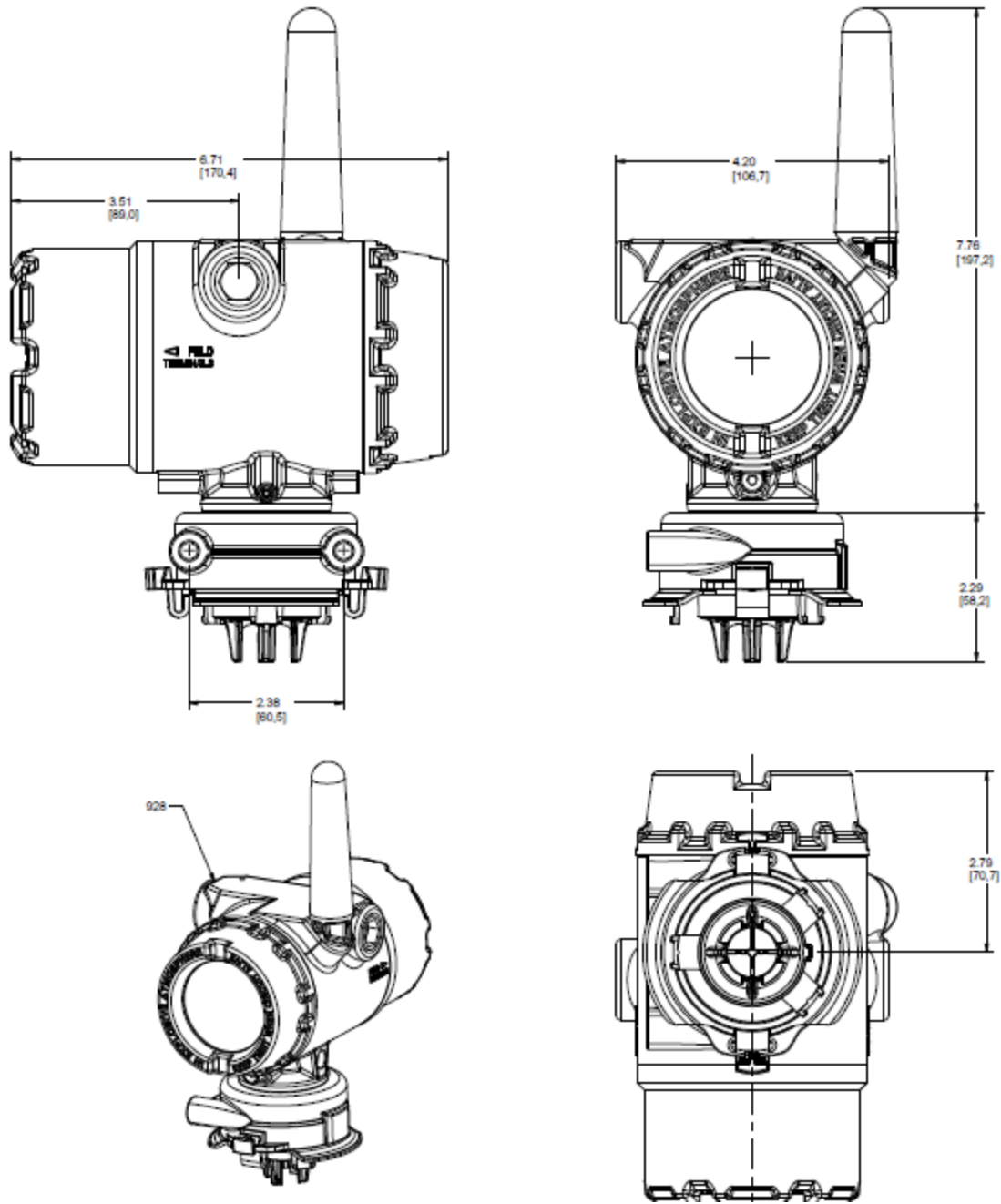

Dimensions are in inches (millimeters).

Figure 2. Mounting Configurations

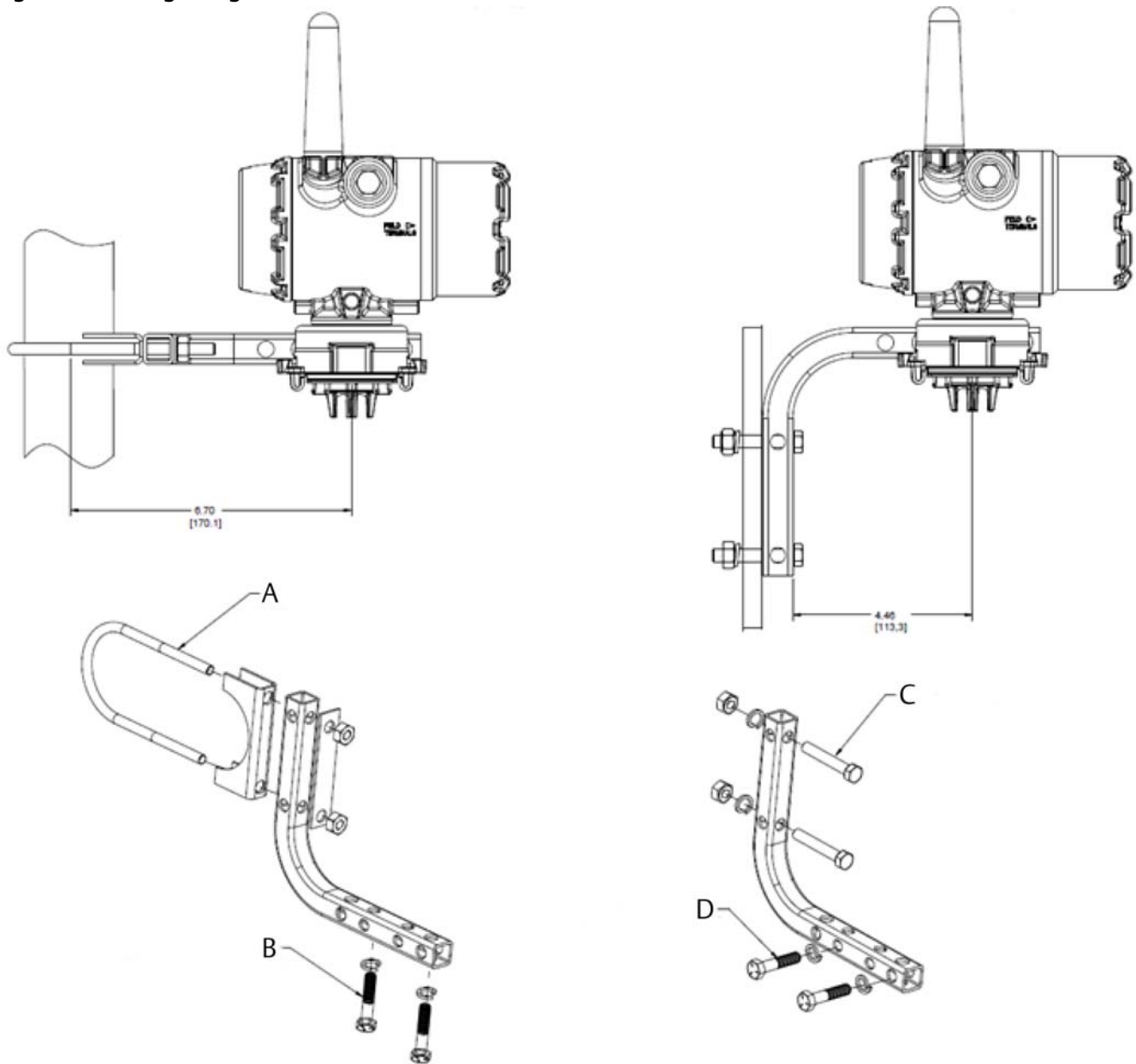

- A. 2-in. bolt for pipe mounting (clamp shown)
- B. 1/4-in. x 1 1/4-in. bolts for transmitter mounting

- C. 5/16-in.-18 bolts for panel mounting (not supplied)
- D. 1/4-in. x 1 1/4-in. bolts for transmitter mounting













Dimensions are in inches (millimeters)



# HIGH ACCURACY

measurement instruments



Our offering:

	<p>Pressure Measurement</p>		<p>Level Measurement</p>
	<p>Temperature Measurement</p>		<p>Flow Measurement</p>
	<p>Marine Measurement &amp; Analytical</p>		<p>Gas Analysis</p>
	<p>Liquid Analysis</p>		<p>Flame and Gas Detection</p>
	<p>Tank Gauging</p>		<p>Wireless Infrastructure</p>
	<p>Acoustic &amp; Discrete</p>		

[www.high-accuracy.com](http://www.high-accuracy.com)



### Global Headquarters

#### Emerson Automation Solutions

6021 Innovation Blvd.  
Shakopee, MN 55379, USA  
 +1 800 999 9307 or +1 952 906 8888  
 +1 952 949 7001  
 Safety.CSC@Emerson.com

### North America Regional Office

#### Emerson Automation Solutions

8200 Market Blvd.  
Chanhassen, MN 55317, USA  
 +1 800 999 9307 or +1 952 906 8888  
 +1 952 949 7001  
 RMT-NA.RCCRFQ@Emerson.com



### Latin America Regional Office

#### Emerson Automation Solutions

1300 Concord Terrace, Suite 400  
Sunrise, FL 33323, USA  
 +1 954 846 5030  
 +1 954 846 5121  
 RFQ.RMD-RCC@Emerson.com

### Europe Regional Office

#### Emerson Automation Solutions Europe GmbH

Neuhofstrasse 19a P.O. Box 1046  
CH 6340 Baar  
Switzerland  
 +41 (0) 41 768 6111  
 +41 (0) 41 768 6300  
 RFQ.RMD-RCC@Emerson.com

### Asia Pacific Regional Office

#### Emerson Automation Solutions

1 Pandan Crescent  
Singapore 128461  
 +65 6777 8211  
 +65 6777 0947  
 Enquiries@AP.Emerson.com

### Middle East and Africa Regional Office

#### Emerson Automation Solutions

Emerson FZE P.O. Box 17033  
Jebel Ali Free Zone - South 2  
Dubai, United Arab Emirates  
 +971 4 8118100  
 +971 4 8865465  
 RFQ.RMTMEA@Emerson.com

 [Linkedin.com/company/Emerson-Automation-Solutions](https://www.linkedin.com/company/Emerson-Automation-Solutions)

 [Twitter.com/Rosemount\\_News](https://twitter.com/Rosemount_News)

 [Facebook.com/Rosemount](https://www.facebook.com/Rosemount)

 [Youtube.com/user/RosemountMeasurement](https://www.youtube.com/user/RosemountMeasurement)

 [Google.com/+RosemountMeasurement](https://www.google.com/+RosemountMeasurement)

Emerson Terms and Conditions of Sale are available upon request.  
The Emerson logo is a trademark and service mark of Emerson Electric Co.  
Rosemount is a mark of one of the Emerson family of companies.  
All other marks are the property of their respective owners.  
© 2018 Emerson. All rights reserved.