



HIGH ACCURACY

m e a s u r e m e n t i n s t r u m e n t s

PRODUCT DATASHEET

www.high-accuracy.com

HandRail Mounting System

- COMPLETE HANDRAIL MOUNTING SYSTEM for sensor mounting
- SWIVEL/PIVOT DESIGN allows multi-axis sensor movement
- VERSATILE ATTACHMENT OPTIONS for floating ball, D.O. sensor, sensor union adapter, and air blast washer head
- SYSTEM IS EASY TO ASSEMBLE and can be locked or allowed to float

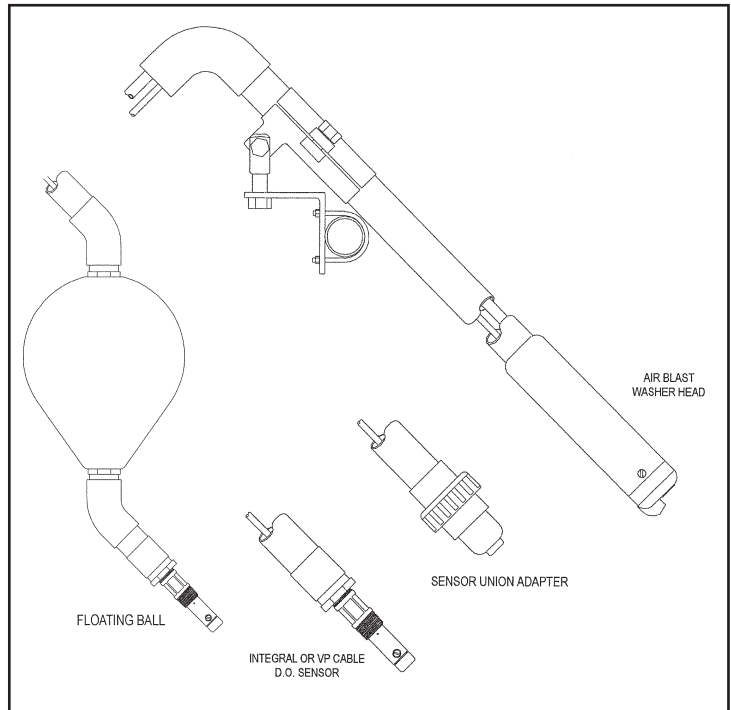

FEATURES AND APPLICATIONS

The Model HRMS-01 and HRMS-02 is a complete system for mounting a Dissolved Oxygen (DO) sensor Model 499ADO to a handrail. It consists of a swivel/pivot pipe clamp for a 1-1/2 inch PVC pipe, and maintenance bracket. The unique swivel/pivot pipe clamp assembly allows easy sensor removal from the process by swinging the pipe boom up and over to the handrail for maintenance. The sensor maintenance bracket allows the pipe boom to be supported in a fixed position while performing maintenance and calibration on the sensor.

The HandRail Mounting System Model HRMS-01 includes the following:

- Sensor union adapter
- Swivel/pivot pipe clamp
- Maintenance bracket
- Elbow

The HandRail Mounting System Model HRMS-02 includes:

- Swivel/pivot pipe clamp
- Maintenance bracket
- Elbow

Model HRMS-01 with the Sensor Union Adapter fitting is designed for use with the Dissolved Oxygen Sensor Model 499ADO. Model HRMS-02 is designed for use with Floating Ball System Model BB11, Air Blast Washer Head, or the DO sensor Model 499ADO.

SENSOR UNION ADAPTER

The HandRail Mounting System Model HRMS-01 shown below includes the unique sensor union adapter, which allows Dissolved Oxygen sensor removal without twisting the sensor cable. Sensor cable twisting is a thing of the past, as the sensor is removed in two easy steps without twisting by (1) unscrewing the plastic union nut, and (2) turning the bottom of the union adapter while holding the DO sensor in place.

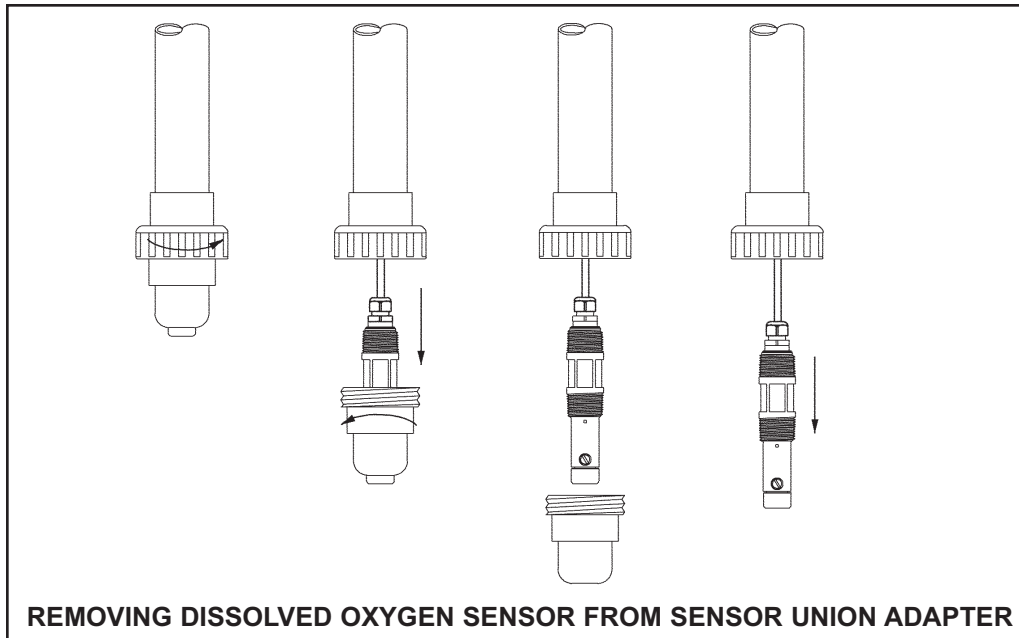

SYSTEM DESCRIPTION

The material of construction of the HandRail Mounting System is aluminum, zinc-plated steel, stainless steel and PVC. The system is supplied in kit form and includes all necessary hardware. The HandRail Mounting System will accommodate a pipe boom using a 1-1/2 inch diameter Schedule 80 PVC pipe. The support arm is available from local stock.

MODEL OPTIONS

The HandRail Mounting Systems Model HRMS is available in two model options. The Model HRMS-01 is designed for DO sensor Model 499ADO and includes the sensor union adapter. The sensor can be removed without twisting the cable. The Model HRMS-02 is designed for use with the Air Blast Washer Head (Model DO-03/04), Floating Ball System (Model BB11), or the DO sensor Model 499ADO.

ASSEMBLY OPTIONS

The hand rail clevis can be assembled using a spring clip or a locking bolt. The spring clip is used with the floating ball system and allows the ball to move up and down freely with process level changes. The bolt locks the handrail in place.

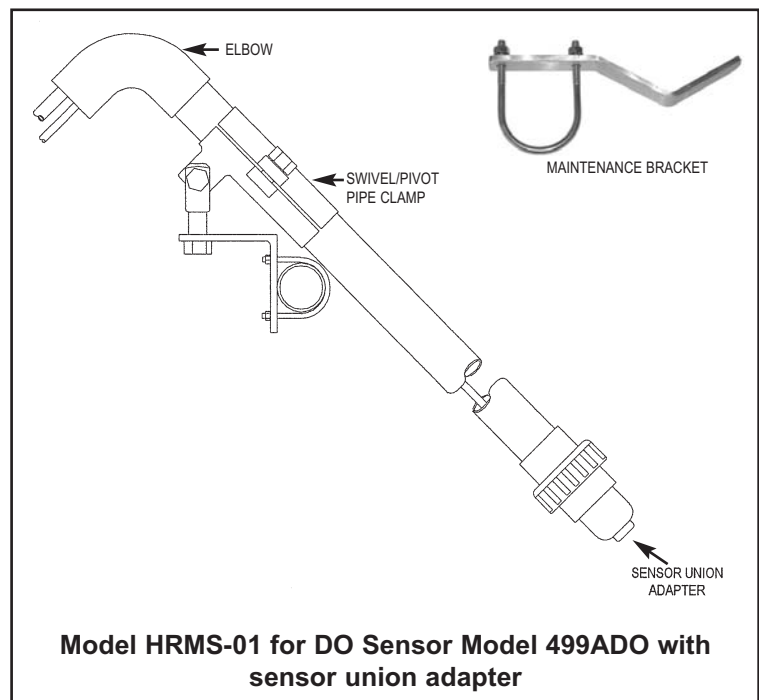

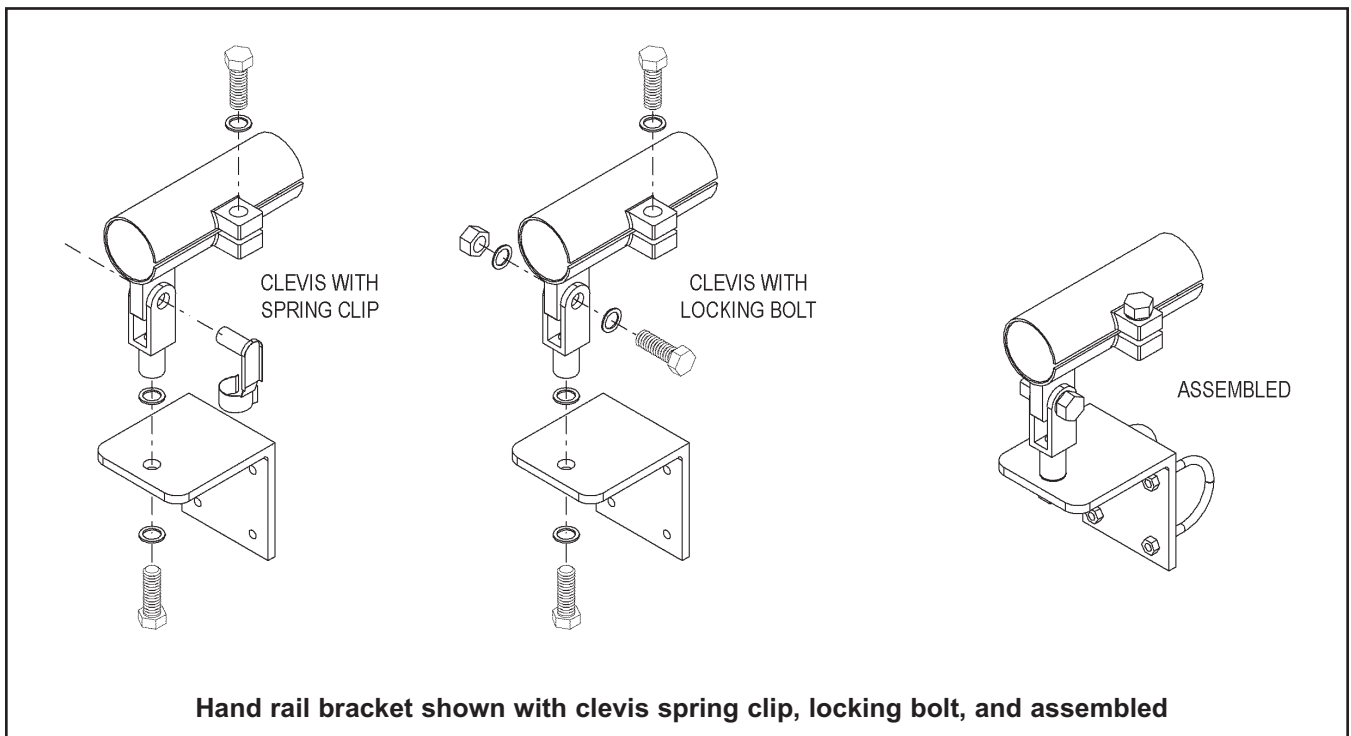
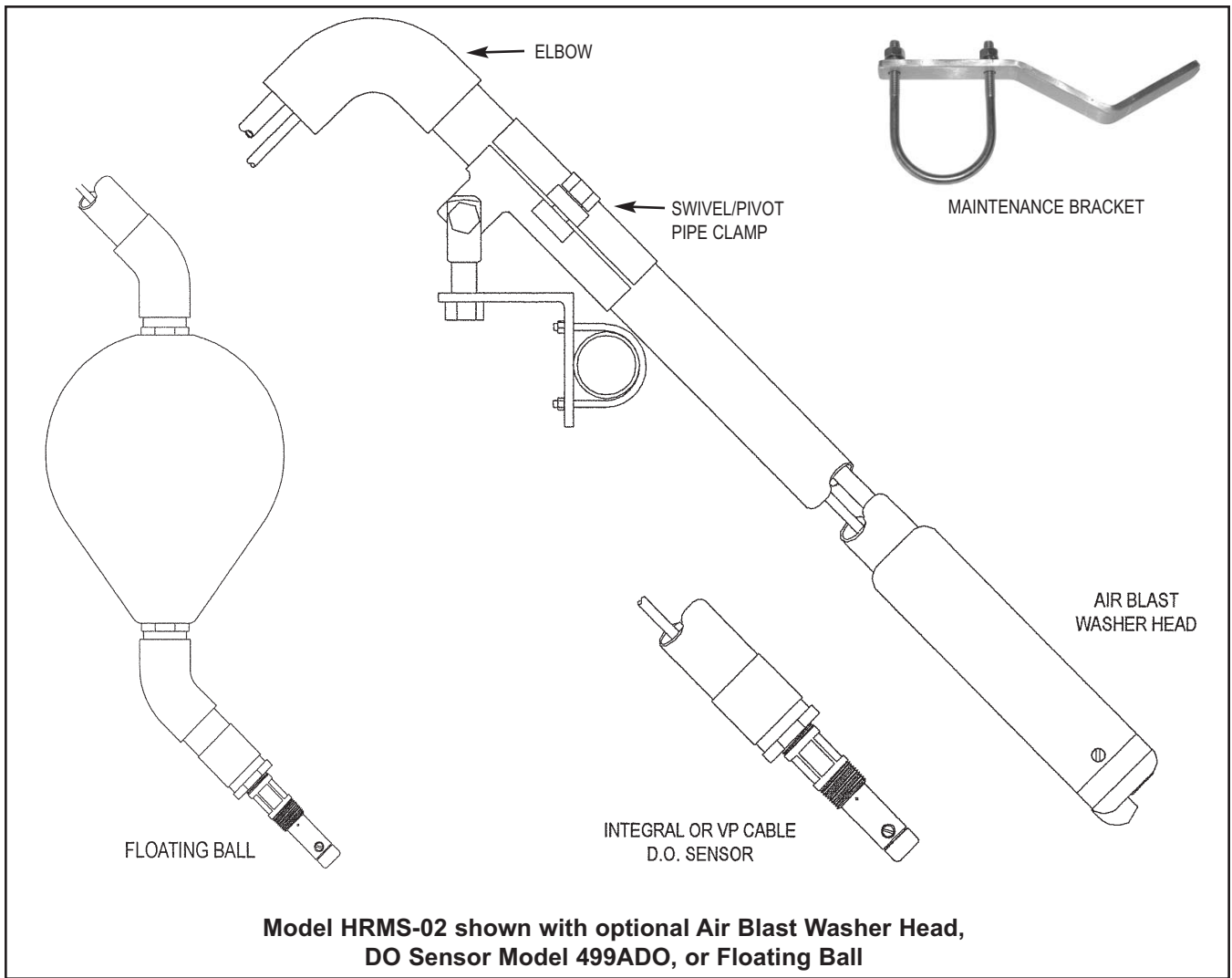

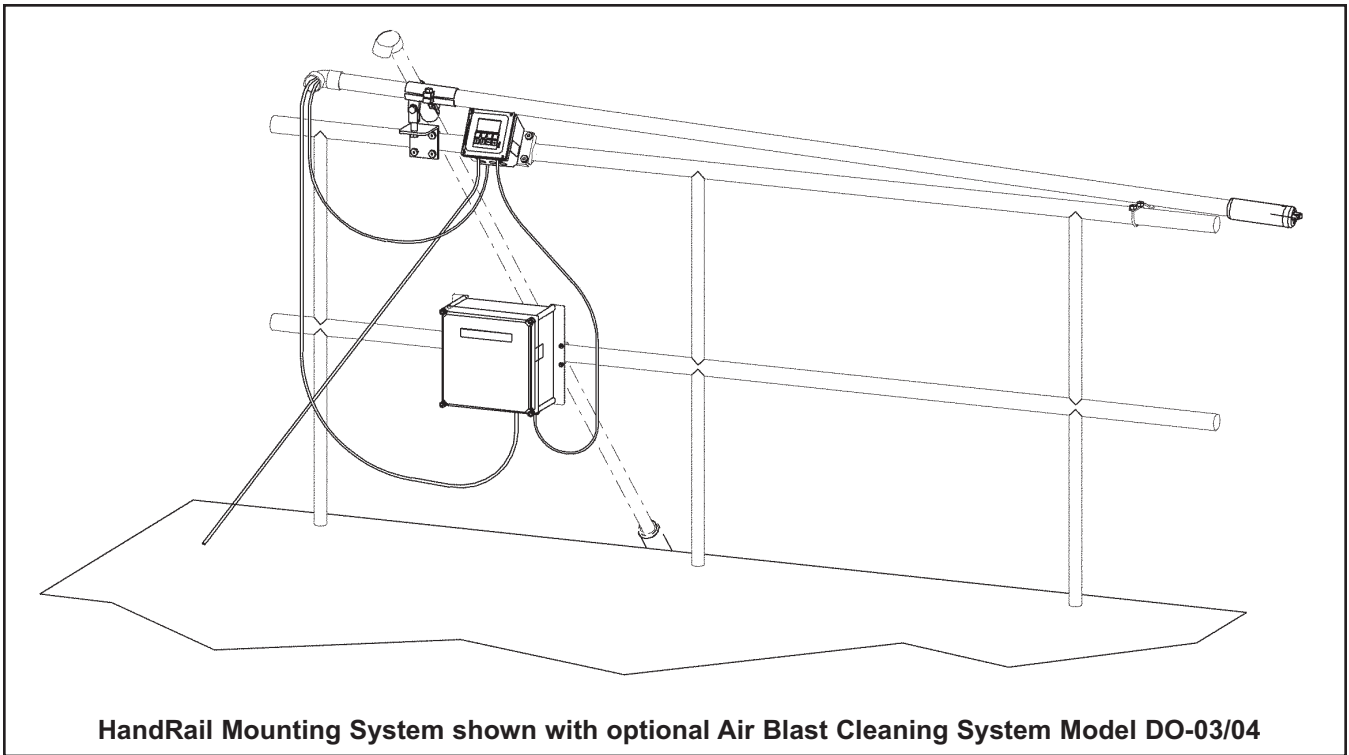

STATIONARY HANDRAIL MOUNTING KIT

In addition to the swivel/pivot handrail mounting system Model HRMS, a stationary handrail mounting kit is also available as PN 11275-01. The stationary handrail mounting kit includes 10 feet (3.0 m) Schedule 80 PVC pipe 1-1/2 inch with a sweep elbow and mounting hardware. The material of construction is aluminum, stainless steel and PVC. The end of the sweep elbow includes a 1-inch FNPT threaded fitting. The sweep elbow will accept any sensor with 1-inch rear facing MNPT connection.

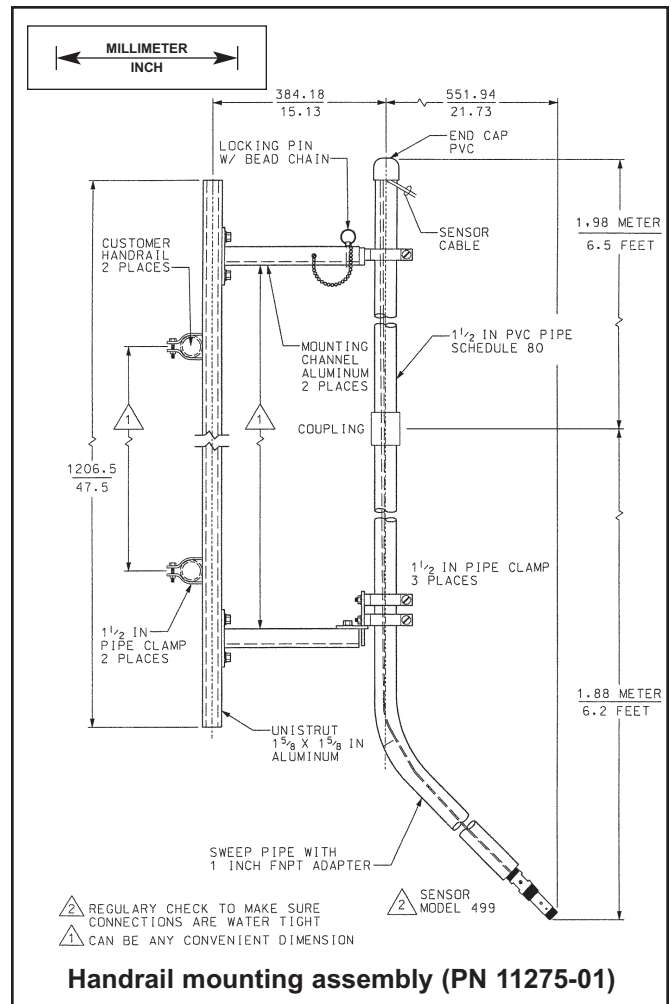

SPECIFICATIONS

Materials of Construction - HRMS-01/02

Weather cap: Schedule 40 PVC
 Pipe clamp and maintenance bracket: Aluminum
 Clevis: Zinc-plated steel
 U-bolts, nut and bolts: Zinc plated steel
 Washers: Stainless steel

Shipping Weight

HRMS-01/02: 5 lb. (2.0 kg)
 PN 11275-01: 22 lb. (10.0 kg)

Materials of Construction - PN 11275-01

Pipe cap, pipe and sweep elbow: Schedule 40 PVC
 Channel unistrut and bracket: Aluminum
 Clamps, straps and mounting hardware: Stainless steel

ORDERING INFORMATION

The Model HRMS can be ordered in two configurations. The Model HRMS-01 option includes the sensor union adapter, a clamp for 1-1/2 inch PVC pipe, maintenance bracket, and elbow. The Model HRMS-02 includes a clamp for 1-1/2 inch PVC pipe, maintenance bracket, and elbow. The 1-1/2 inch diameter PVC pipe boom is not included.

MODEL	DESCRIPTION
HRMS	Hand Rail Mounting System
CODE	DESCRIPTION (required selection)
01	Hand Rail Mounting System with Sensor Union Adapter fitting (includes a clamp for 1-1/2 inch PVC pipe, maintenance kit, and elbow). For use with the Dissolved Oxygen Sensor Model 499ADO.
02	Hand Rail Mounting System (includes a clamp for 1-1/2 inch PVC pipe, maintenance kit, and elbow). For use with Model BB11 Floating Ball System, an Auto Air Blast Washer Head, or the Model 499ADO.

REPLACEMENT PARTS AND ACCESSORIES

PART #	DESCRIPTION
11275-01	Fixed handrail mounting kit: includes 10 ft (3.0 m) Schedule 80 1-1/2 inch PVC pipe with sweep ell and all mounting hardware
24056-00	Sensor union adapter fitting, PVC 1-1/2 in. pipe socket
24044-00	Maintenance Bracket Kit (bracket and complete replacement hardware)

SAMPLE ENGINEERING SPECIFICATION:

For Model HRMS-01:

DO sensor handrail mechanism shall be a swivel/pivot design to hold the sensor in the process. The swivel/pivot design shall include a swivel/pivot pipe clamp, maintenance bracket, all necessary hardware, and sensor union adapter. The swivel/pivot design shall allow sensor removal from the process and allow the pipe boom to be supported in a fixed position using a sensor maintenance bracket. The sensor union adapter shall allow for easy removal of the DO sensor without twisting the sensor cable. The system will be designed to accommodate a 1-1/2 inch diameter Schedule 80 PVC pipe and be used with the Rosemount DO Sensor Model 499ADO. Handrail mechanism shall be Rosemount Model HRMS-01 or approved equal.

For Model HRMS-02:

DO sensor handrail mechanism shall be a swivel/pivot design to hold the sensor in the process. The swivel/pivot design shall include a swivel/pivot pipe clamp, maintenance bracket, and all necessary hardware. The swivel/pivot design shall allow sensor removal from the process and allow the pipe boom to be supported in a fixed position using a sensor maintenance bracket. The system will be designed to accommodate a 1-1/2 inch diameter Schedule 80 PVC pipe and can be used with the Floating Ball System Model BB11, Auto Air Blast Washer Head, or the Rosemount DO Sensor Model 499ADO. Handrail mechanism shall be Rosemount Model HRMS-02 or approved equal.

For PN 11275-01:

DO Sensor handrail mechanism shall be a sweep elbow design to hold the sensor in the process. The mechanism shall include 10 feet (3.0 m) Schedule 80 PVC pipe 1-1/2 inch with a sweep elbow and mounting hardware. The handrail mechanism shall allow for easy sensor removal from the process, and can be used with the Rosemount DO Sensor Model 499ADO. Handrail mechanism shall be Rosemount PN 11275-01 or approved equal.



*The right people,
the right answers,
right now.*



ON-LINE ORDERING NOW AVAILABLE ON OUR WEB SITE
<http://www.raihome.com>

Specifications subject to change without notice.



Credit Cards for U.S. Purchases Only.



Emerson Process Management

Liquid Division

2400 Barranca Parkway
Irvine, CA 92606 USA
Tel: (949) 757-8500
Fax: (949) 474-7250













<http://www.raihome.com>



HIGH ACCURACY

measurement instruments

Our offering:

	<p>Pressure Measurement</p>		<p>Level Measurement</p>
	<p>Temperature Measurement</p>		<p>Flow Measurement</p>
	<p>Marine Measurement & Analytical</p>		<p>Gas Analysis</p>
	<p>Liquid Analysis</p>		<p>Flame and Gas Detection</p>
	<p>Tank Gauging</p>		<p>Wireless Infrastructure</p>
	<p>Acoustic & Discrete</p>		

www.high-accuracy.com