



HIGH ACCURACY

m e a s u r e m e n t i n s t r u m e n t s

PRODUCT DATASHEET

www.high-accuracy.com

Incus Ultrasonic Gas Leak Detector

Wide Area Coverage for Pressurized Gas Leaks

The Incus is an advanced gas leak detector that uses four sensitive acoustic sensors to monitor wide areas for the ultrasound generated from pressurized gas releases.

Ideally suited for monitoring ventilated outdoor applications, the Incus has been engineered to withstand extreme conditions. Detection is unaffected by inclement weather, wind, leak direction, or gas dilution, with fast speed of response.

- Instantaneous response to all gas leaks (toxic, combustible, or inert).
- Operates in extreme temperatures.
- Automated electronic self-test offers failsafe operation.
- Widest area of coverage through four independent sensors 4–20 mA analog or stepped and HART® communication protocol.
- Certified worldwide for hazardous locations.
- Innovative mapping tool helps optimize coverage for a target risk.
- Programmable time delays screen intermittent unwanted alarm sources.

Four multi-directional sensor heads

Quad sensing heads provide the widest overall detection range available on the market. The sensing heads are independent with the detector output being based on the highest ultrasound measured by any one head. If one or more sensing heads fails, complete coverage is not lost.

Field-proven ultrasonic sensor principle

Incus responds to the ultrasound produced by pressurized gas releases, a technology proven with hundreds of detectors installed worldwide.

Sealed sensor housing

Piezoceramic sensor heads have no moving parts and can therefore be completely sealed against moisture, corrosive atmospheres, and industrial contaminants.



Incus Ultrasonic Gas Leak Detector

Sensor design - they just keep working

Each sensor is completely free of moving parts and will not age, drift, or ever need replacing under normal operating conditions. The sensors provide maintenance free protection with proven reliability.

Continuous self-test ensures instrument health

Electronic self-test checks the detector every 320 ms by sending an amplitude signal through the sensing circuitry. The sensor suffers no loss of detection while in test mode in contrast to those based on diaphragm microphones.

Built for extreme conditions

The Incus is designed to operate at -40 °C to +85 °C (-40 °F to +185 °F) and may be supplied for monitoring areas of regard at -55 °C (-67 °F). Corrosion resistant stainless steel housing is standard, units are ingress rated to IP66/67 or NEMA Type 4X.

Ultrasonic detection overview

Ultrasonic (acoustic) gas leak detection technology functions through the constant monitoring of wide areas by advanced acoustic sensors specially tuned to process ultrasound emitted from pressurized gas leaks. Ultrasonic gas leak detectors do not have to wait until a hazardous concentration has accumulated or the gas cloud has made physical contact with a sensor. In addition, the response is instantaneous for all gas types (Figure 1).

Simply put, the ultrasonic gas leak detector only triggers an alarm when inaudible, ultrasound is detected (between 25 and 100 kHz), which is only produced with the release of highly pressurized gas (Figure 2). This makes for reliable and efficient detection; since ultrasonic gas leak detectors are immune to poisoning, it never requires field calibration, and all intermittent sources of background ultrasound noises may be ignored by time delay settings.

Figure 1

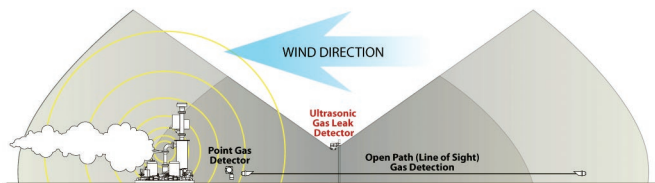

The Incus detects gas leaks at the speed of sound while providing wide area coverage. It is unaffected by inclement weather, wind, leak direction, and gas dilution or stratification. When used with Emerson’s point gas and optical flame detectors, a complete and comprehensive safety system is ensured (Figure 3).

Figure 2

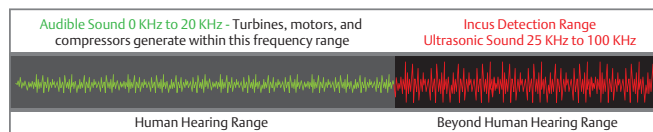
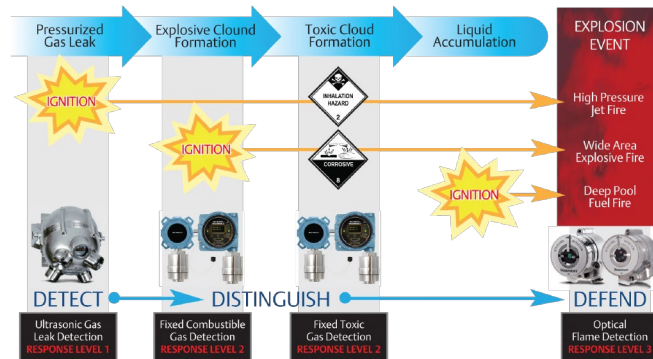

Figure 3



Specifications

Table 1 - Incus Ultrasonic Gas Leak Detector

Incus			
Detection frequency range	25 kHz to 100 kHz		
Dynamic range	40–120 dB (standard); 58–104 dB or 40–200 dB		
Area coverage	2 to 20 meters (7 to 65 feet) radius (leak pressure, size and background level dependent)		
Response time	Instantaneous (< 1 s - speed of sound)		
Programmable alarm delay	Configurable alarm delay via one second increments		
Operating temperatures	-40 °C to +85 °C (-40 °F to +185 °F), option -55 °C (-67 °F), NOT c FM us approved		
Operating humidity range	0 to 100 % relative humidity, non-condensing		
Self test	Continuous electronic check of sensor integrity		
Ingress protection	Rated IP66/67 & NEMA Type 4X to withstand harsh environments		
Enclosure material	AISI 316 stainless steel		
Mounting bracket	AISI 316 stainless steel (included)		
Weight (with bracket)	18 kg (40 lb)		
Conduit entry	½ in. or ¾ in. NPT available as single entry (all listings) or M20/M25 single entry and all dual entry (all listings EXCEPT FM)		
Output signals	Analog [0 mA: zero/low power, 0.5 mA to 4.0 mA: detector faults, 4–20 mA]	Two form C relay contacts [Error/fault, alarm, maintenance]	HART® protocol
Approvals/classifications	IECEX ITS 10.0004X ATEX Ex d ib IIB+H2T4 Gb (Tamb -40 °C to +85 °C); (Tamb -55 °C to +85 °C) option c FM us CL1 Division 1, GP B, C, D T4 CL1 Zone I, AEx/Ex d ib IIB+H2 T4 EAC RU C-GB.ГБ04.B.00297 KOSHA: 14-KB4BO-0294X INMETRO UL-BR 15.0063X ABS: 13-LD1021861 DNV: A-13745 SIL 2 suitable EMC: EN 50270 2006, EN 61000-6-3 2007, EN 61000-6-2 2005		
Input voltage	24 Vdc (15 to 30 Vdc)		
Power consumption	6 W - standard operation		
Warranty	18 months after shipment or 12 months after installation, whichever comes first		

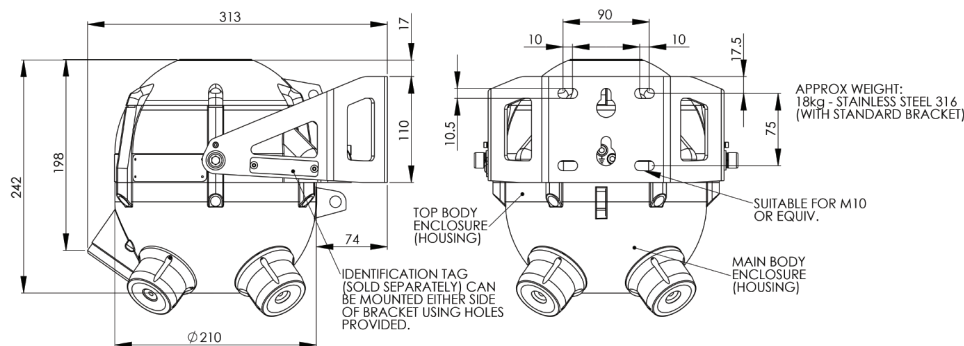

Ordering information
Accessories
- GDU-01-TT Test transmitter: handheld rechargeable ultrasonic sound emitter
- GDU-01-MT Mapping tool: handheld rechargeable ultrasonic sound receiver
- GDU-PTV Performance target verification kit

Product certifications

Ordinary location certification

As standard, the transmitter has been examined and tested to determine that the design meets the basic electrical, mechanical, and fire protection requirements by a nationally recognized test laboratory (NRTL) as accredited by the Federal Occupational Safety and Health Administration (OSHA).

Installing equipment in North America

The US National Electrical Code (NEC) and the Canadian Electrical Code (CEC) permit the use of Division marked equipment in Zones and Zone marked equipment in Divisions. The markings must be suitable for the area classification, gas, and temperature class. This information is clearly defined in the respective codes.

USA

FM Explosionproof (XP)

Certificate: 3043275

Standards: FM Class 3600 – 2011,
FM Class 3615–2006,
FM Class 3810–2005,
ANSI/ISA 60079-0–2009,
ANSI/ISA 60079-1–2009,
ANSI/ISA 60079-11–2011,
ANSI/NEMA 250–1991

Markings: XP CL I, DIV 1, GP B, C, D;
T4 (-40 °C ≤ Ta ≤ +85 °C); CL 1, Zone 1,
AEx d ib IIB+H2 T4 (-40 °C ≤ Ta ≤ +85 °C);
Type 4X

Canada

CSA Explosionproof

Certificate: 3043275

Standards: CSA-C22.2 No. 0.4-04–2009,
CSA-C22.2 No. 0.5-82–2008,
CSA-C22.2 No. 30-86–2012,
CSA-C22.2 No. 94-91 – 2011,
CSA-C22.2 No. 157-92–2012,
CSA-C22.2 No. 1010.1–2004,
CAN/CSA 60079-0–2011,
CAN/CSA 60079-1–2011,
CAN/CSA 60079-11–2011

Markings: XP CL I, DIV 1, GP B, C, D;
T4 (-40°C ≤ Ta ≤ +85°C);
CL I, Zone 1, Ex d ib IIB+H2 T4
(-40 °C ≤ Ta ≤ +85 °C); Type 4X

Europe

ATEX Flameproof

Certificate: ITS09ATEX16836X

Standards: EN 60079-0: 2012, EN 60079-1: 2007,
EN 60079-11: 2012

Markings: ⓂII 2 G Ex d ib IIB+H2 T4 Gb
(Tamb -55 °C/-40 °C to +85 °C); IP66/67

Special conditions for safe use (X):

1. No modifications must be made to the flamepaths of the unit without consultation of the schedule drawings listed in section 19 of the ATEX certificate.
2. When the temperature at the cable entry could exceed 70 °C (158 °F) or 80 °C (176 °F) at the branching point, suitably rated cable must be selected based on the T-Class/Tmax.
3. Property Class of the tested stainless steel fasteners is AA-70, minimum yield strength 450 MPa.
4. Suitably approved cable glands only to be used for cable entry.
5. Any unused entries must be blanked using suitably approved blanking plugs.

International

IECEx Flameproof

Certificate: IECEx ITS 10.0004X

Standards: IEC 60079-0:2007-10,
IEC 60079-1:2007-04,
IEC 60079-11:2006

Markings: Ex d ib IIB+H2 T4 Gb
(Tamb -55°C /-40°C to +85°C)

Special conditions for safe use (X):

1. No modifications must be made to the flamepaths of the unit without consultation of the drawings listed in ExTR 10.0027/00.
2. When the temperature at the cable entry could exceed 70 °C (158 °F) or 80 °C (176 °F) at the branching point, suitably rated cable must be selected based on the T-Class/Tmax.
3. Fastener yield strength minimum required to 450 MPa property class AA-70.
4. Suitably approved cable glands only to be used.
5. Any unused entries must be blanked using suitably approved blanking plugs.

Notes









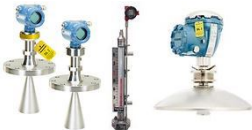

Notes



HIGH ACCURACY

measurement instruments

Our offering:

	<p>Pressure Measurement</p>		<p>Level Measurement</p>
	<p>Temperature Measurement</p>		<p>Flow Measurement</p>
	<p>Marine Measurement & Analytical</p>		<p>Gas Analysis</p>
	<p>Liquid Analysis</p>		<p>Flame and Gas Detection</p>
	<p>Tank Gauging</p>		<p>Wireless Infrastructure</p>
	<p>Acoustic & Discrete</p>		

www.high-accuracy.com



Global Headquarters

Emerson Automation Solutions

6021 Innovation Blvd.
Shakopee, MN 55379, USA
 +1 800 999 9307 or +1 952 906 8888
 +1 952 949 7001
 Safety.CSC@Emerson.com



North America Regional Office

Emerson Automation Solutions

8200 Market Blvd.
Chanhassen, MN 55317, USA
 +1 800 999 9307 or +1 952 906 8888
 +1 952 949 7001
 RFQ-NA.RCCRFQ@Emerson.com



Latin America Regional Office

Emerson Automation Solutions

1300 Concord Terrace, Suite 400
Sunrise, FL 33323, USA
 +1 954 846 5030
 +1 952846 5121
 RFQ.RMD-RCC@Emerson.com

Europe Regional Office

Emerson Automation Solutions Europe GmbH

Neuhofstrasse 19a P.O. Box 1046
CH 6340 Baar
Switzerland
 +1 954 846 5030
 +1 952846 5121
 RFQ.RMD-RCC@Emerson.com



Asia Pacific Regional Office

Emerson Automation Solutions Asia Pacific Pte LTD

1 Pandan Crescent
Singapore 128461
 +65 6777 8211
 +65 6777 0947
 Enquiries@AP.Emerson.com

Middle East and Africa Regional Office

Emerson Automation Solutions

Emerson FZE P.O. Box 17033
Jebel Ali Free Zone - South 2
 +971 4 8118100
 +971 4 88665465
 RFQ.RMTMEA@Emerson.com



Analyticexpert.com



[Linkedin.com/company/Emerson-Automation-Solutions](https://www.linkedin.com/company/Emerson-Automation-Solutions)



[Twitter.com/Rosemount_News](https://twitter.com/Rosemount_News)



[Facebook.com/Rosemount](https://www.facebook.com/Rosemount)



[Youtube.com/user/RosemountMeasurement](https://www.youtube.com/user/RosemountMeasurement)



[Google.com/+RosemountMeasurement](https://plus.google.com/+RosemountMeasurement)

The Emerson logo is a trademark and service mark of Emerson Electric Co.
Rosemount and Rosemount logotype are trademarks of Emerson.
All other marks are the property of their respective owners.
© 2017 Emerson. All rights reserved.