



HIGH ACCURACY

m e a s u r e m e n t i n s t r u m e n t s

PRODUCT DATASHEET

www.high-accuracy.com

Mobrey MSM400

Ultrasonic Suspended Solids Monitoring and Control System



- Continuous sludge discharge monitor for up to 50% suspended solids
- Rugged 316 stainless steel sensors for in-tank mounting
- Choice of flanged pipeline sensors for in-line density measurement
- Blanket level detection for primary and secondary sludge and industrial slurries

Overview of the Mobrey MSM400



The MSM400 system contains a control unit and either a tank-mountable sensor or pipe-section with integral sensors

The Mobrey MSM400 ultrasonic suspended solids monitoring and control system can continuously monitor the suspended solids or sludge density contained in, or flowing from, a clarifier or settlement tank during de-sludging.

Measurement principle

Many years of practical experience have shown that measurement of ultrasonic attenuation in a slurry is directly proportional to the percentage of suspended solids.

The MSM400 system uses this principle to produce a digital display of the suspended solids measurement.

Features and benefits

Control unit

- Bright local display of the measured value and statuses
- 4–20 mA / HART output signal of measured value
- Two SPDT (single-pole-double-throw) relays for control and alarm indication purposes
- A digital trigger input can perform various control actions
- Comes complete with a range of user-selectable calibration settings for simple initial set-up, but can also be calibrated against samples analyzed for % solids in a laboratory
- Provides the automatic control sequence to start a pump or control a valve for sludge or settled product removal
- Local programming of the control unit is supported using the integral keypad and an easy to navigate menu structure
- Remote programming and monitoring is supported using a Field Communicator or a smart wireless THUM™ adapter
- Auto-selection of AC or DC power supply, allowing back-up if one power supply fails



Robust stainless steel sensors may be tank mounted or housed in a pipe-section sensor on the clarifier

Intrinsically safe sensors

- Dual-operating-frequency gap sensors, 1 MHz or 3.3 MHz

Contents

MSM400 Control Unit and Sensors Ordering	page 3	Specifications for Pipe-section with Sensors	page 5
Specifications for Control Unit	page 4	Product Certifications	page 6
Specifications for Tank-mountable Sensors	page 5	Dimensional Drawings	page 7

MSM400 Control Unit and Sensors Ordering

Specification and selection of product materials, options, or components must be made by the purchaser of the equipment. See [Material selection](#) below for more information.

Table 1. MSM400 control unit ordering information

Model	Product Description
MSM400 ⁽¹⁾	Control unit, ATEX and IECEx intrinsically safe certified, IP65
Typical Model Number: MSM400	

(1) Only the gap sensor inputs on the control unit are intrinsically safe certified. The control unit itself must be sited in a non-hazardous area.

Table 2. MSM400 sensors ordering information

★The Standard offering represents the most common options. The starred options (★) should be selected for best delivery. The Expanded offering is subject to additional delivery lead time.

Model	Product Description	
MSM433	Tank-mount sensor	
MSM448	Pipe section with sensors	
Approval		
Standard		Standard
A	Intrinsically safe (ATEX and IECEx)	★
Size⁽¹⁾		
Standard		Standard
100T	1 / 3.3 MHz 4 in. (100 mm) gap tank sensor	★
150T	1 / 3.3 MHz 6 in. (150 mm) gap tank sensor	★
200T	1 / 3.3 MHz 8 in. (200 mm) gap tank sensor	★
300T	1 / 3.3 MHz 12 in. (300 mm) gap tank sensor	★
450T	1 / 3.3 MHz 18 in. (450 mm) gap tank sensor	★
100	1 / 3.3 MHz flanged PN10/PN16 DN100 pipe section with gap sensors	★
150	1 / 3.3 MHz flanged PN10/PN16 DN150 pipe section with gap sensors	★
200	1 / 3.3 MHz flanged PN10 DN200 pipe section with gap sensors	★
A10	1 / 3.3 MHz flanged ASME B16.5 Class 150 4 in. (100 mm) pipe section with gap sensors	★
A15	1 / 3.3 MHz flanged ASME B16.5 Class 150 6 in. (150 mm) pipe section with gap sensors	★
A20	1 / 3.3 MHz flanged ASME B16.5 Class 150 8 in. (200 mm) pipe section with gap sensors	★
Spray Valve		
Standard		Standard
V	Spray valve (pipe section only code)	★
P	No spray valve (pipe section only code)	★
Cable Length⁽²⁾		
Standard		Standard
D / M07	23 ft. (7 m) cable	★
Typical Model Numbers: MSM433A150TD/M07 or MSM448AA15VD/M07		

(1) Sensor size selection depends on the application. If in doubt, please contact Rosemount Measurement to ensure that the size is suitable for the application.

(2) For other cable lengths, contact Rosemount Measurement. The maximum cable length is 164 ft. (50 m).

Material selection

- Emerson provides a variety of products with various product options and configurations including materials of construction that can be expected to perform well in a wide range of applications. The product information presented is intended as a guide for the purchaser to make an appropriate selection for the application. It is the purchaser's sole responsibility to make a careful analysis of all process parameters (such as all chemical components, temperature, pressure, flow rate, abrasives, contaminants, etc.), when specifying product, materials, options and components for the particular application. Emerson Process Management is not in a position to evaluate or guarantee the compatibility of the process fluid or other process parameters with the product, options, configuration or materials of construction selected.

Specifications for Control Unit

Product

- Mobrey MSM400 control unit

Physical

Mounting style

- Wall mount (brackets included)
- Six mounting holes, 0.2 in. (5 mm) diameter

Display

- Integral 32 x 122 pixels LCD with backlight, providing up to four lines of characters

Keypad

- Integral membrane keypad with six buttons for menu system navigation and configuring the application

Conduit/cable entries

- Six conduit/cable entry positions, pre-drilled at bottom of the enclosure
- Supplied with three M20 glands and three M16 glands

Dimensions

- See “Dimensional Drawings” on page 7

Construction materials

- ABS enclosure with clear polycarbonate lid
- 304-grade stainless steel cover-fixing screws
- UV resistant polycarbonate membrane keypad
- Nylon cable glands and blanking/stopping plugs

Electrical

General

- Cage clamp terminal blocks in separate compartment
- Maximum wire size is 2.5 mm² (12 AWG)

Power supply input connections

- Alternating Current (AC) mains and Direct Current (DC) terminal connections on each control unit for external supply
- Auto-selection of AC or DC supply, allowing back-up if one power supply fails

AC power supply requirements:

- 115 or 230 Vac ±15% (switch selectable)
- Power consumption: 10 VA nominal
- Fuse (F1): 200 mA (T), 5x20 mm, 240 V

DC power supply requirements:

- 15 to 30 Vdc, 24 Vdc nominal
- Power consumption: 6 W nominal

Sensor input connections

- Captive screw terminal block for 1 x ultrasonic gap sensor (Mobrey MSM433 or Mobrey MSM448)
- 1 MHz or 3.3 MHz operating frequency auto-selection

Digital input connections

- Accepts two 5 Vdc trigger input signals
- 5 Vdc provided by control unit

Other input connections

- Field communicator connection points (HART test points A and B)

Current output connections

- Nominal signal range 4–20 mA (default) or 0–20 mA, software selectable
- Full output range (linear): 3.8 to 20.5 mA (See Table A-1 on page A-3 for current saturation and alarm indication levels)
- Load: maximum resistance is 1 K Ohm at 22 mA
- Maximum applied voltage: 48 Vdc
- Isolated from other terminals to 500 Vdc
- Update rate (software): 10 times every second

Relay output connections

- Two SPDT (single-pole-double-throw) relays, rated 5 A at 240 Vac resistive

Environment

Ambient temperature

- –22 to 131 °F (–30 to 55 °C)

Relative humidity

- 95%

Enclosure rating

- IP65 indoor and outdoor

Certifications

See “Product Certifications” on page 6 for certified approvals.

Specifications for Tank-mountable Sensors

Product

- Mobrey MSM433 tank-mountable ultrasonic gap sensor, 316 Stainless steel, 1 MHz / 3 MHz operating frequency
- Gap size 4, 6, 8, 12, or 18 in (100, 150, 200, 300, or 450 mm)

Connections

Mounting connection

- ¾-in. BSPT

Sensor cable

- 23 ft. (7m) dual screened/shielded twisted pair (others upon request)
- Ready to connect to the MSM400 control unit

Environment

Operating temperature

- -40 to 130 °F (-40 to 55 °C)
- Up to +212 °F (+100 °C) upon request
- See also “Product Certifications” on page 6 for approval temperature ranges

Operating pressure

- 1522 psi (105 bar)

Ingress protection

- IP68

Certifications

See “Product Certifications” on page 6 for certified approvals.

Specifications for Pipe-section with Sensors

Product

- Mobrey MSM448 pipe-section with integral 316 stainless steel ultrasonic gap sensor, 1 MHz / 3 MHz operating frequency
- Gap size 4, 6, 8, 12, or 18 in (100, 150, 200, 300, or 450 mm), depending on pipe size/flange choice

Physical

Pipe-section material

- Epoxy-coated carbon steel

Spray nozzle/flushing valve

- 1-in. BSP thread,
- 316 stainless steel wetside

Drain fitting

- 1-in. NPT

Connections

Mounting connection

- Raised Face (RF) flanged in-line installation
- EN1092-1 DN100 (PN 10/PN 16), DN150 (N 10/PN 16), DN200 (PN 10) or 4-in., 6-in., 8-in. ASME B16.15 Class 150

Sensor cable

- 23 ft. (7m) from junction box, oil hose protected, dual screened twisted pair (others upon request)
- Ready to connect to the MSM400 control unit

Cable junction box

- IP65 aluminum alloy

Environment

Operating temperature

- -40 to 158 °F (-40 to 70 °C)

Operating pressure

- 145 psi (10 bar)

Ingress protection

- IP68

Certifications

See “Product Certifications” on page 6 for certified approvals.

Product Certifications

Approved manufacturing location

Rosemount Measurement Limited

Slough, United Kingdom

European directive information

The EC declaration of conformity for all applicable European directives for this product can be obtained by contacting your local sales office.

ATEX directive (94/09/EC)

- The control unit and gap sensors comply with EN60079-0 and EN60079-11

Low voltage directive (2006/95/EC)

- The control unit complies with EN61010-1
- The gap sensors are outside the scope of the LVD directive

Pressure equipment directive (PED) (97/23/EC)

- The control unit and in-tank mounted gap sensor are outside the scope of the PED Directive
- The pipe-section gap sensor complies with the PED directive

Electro magnetic compatibility (EMC) directive (2004/108/EC)

- The control unit and sensors comply with EN 61326-1

CE-mark

- The control unit and sensors comply with the applicable directives

Hazardous location certifications

The MSM400 control unit ("control unit") may be connected to an intrinsically safe gap sensor located in a hazardous area. The control unit must not itself be located in a hazardous area.

Control unit approvals

ATEX intrinsically safe approval (gap sensor inputs only)

Certificate numbers: ITS00ATEX2002X
Intrinsically safe for II (1) G, (Ga) [Ex ia] IIC
Ambient temperature: -40 to +55 °C

Channel 1 (Rx) electrical parameters:
U_o = 1.2 V, I_o = 42.1 mA, P_o = 13 mW, C_o = 0.4 nF,
L_o = 0.04 mH

Channel 2 (Tx) electrical parameters:
U_o = 4.6 V, I_o = 162 mA, P_o = 0.2 W, C_o = 0.4 nF,
L_o = 0.04 mH

IECEx intrinsically safe approval (gap sensor inputs only)

Certificate numbers: IECEx ITS 13.0044X
Intrinsically safe for (Ga) [Ex ia] IIC
Ambient temperature: -40 to +55 °C

Channel 1 (Rx) electrical parameters:
U_o = 1.2 V, I_o = 42.1 mA, P_o = 13 mW, C_o = 0.4 nF,
L_o = 0.04 mH

Channel 2 (Tx) electrical parameters:
U_o = 4.6 V, I_o = 162 mA, P_o = 0.2 W, C_o = 0.4 nF,
L_o = 0.04 mH

Gap sensor approvals

ATEX intrinsically safe approval

A Certificate numbers: ITS00ATEX2003X
Intrinsically safe for II 1 G, Ex ia IIC T6...T3 Ga
Ambient temperature: -40 to +70 °C

Electrical parameters:
U_i = 4.6 V, I_i = 162 mA, P_i = 0.2 W, C_i = 14 nF, L_i = 0.1 mH

IECEx intrinsically safe approval

A Certificate numbers: IECEx ITS 13.0044X
Intrinsically safe for Ex ia IIC T6...T3 Ga
Ambient temperature: -40 to +70 °C

Electrical parameters:
U_i = 4.6 V, I_i = 162 mA, P_i = 0.2 W, C_i = 14 nF, L_i = 0.1 mH

Dimensional Drawings

Control unit

Note: Dimensions are in inches (mm)

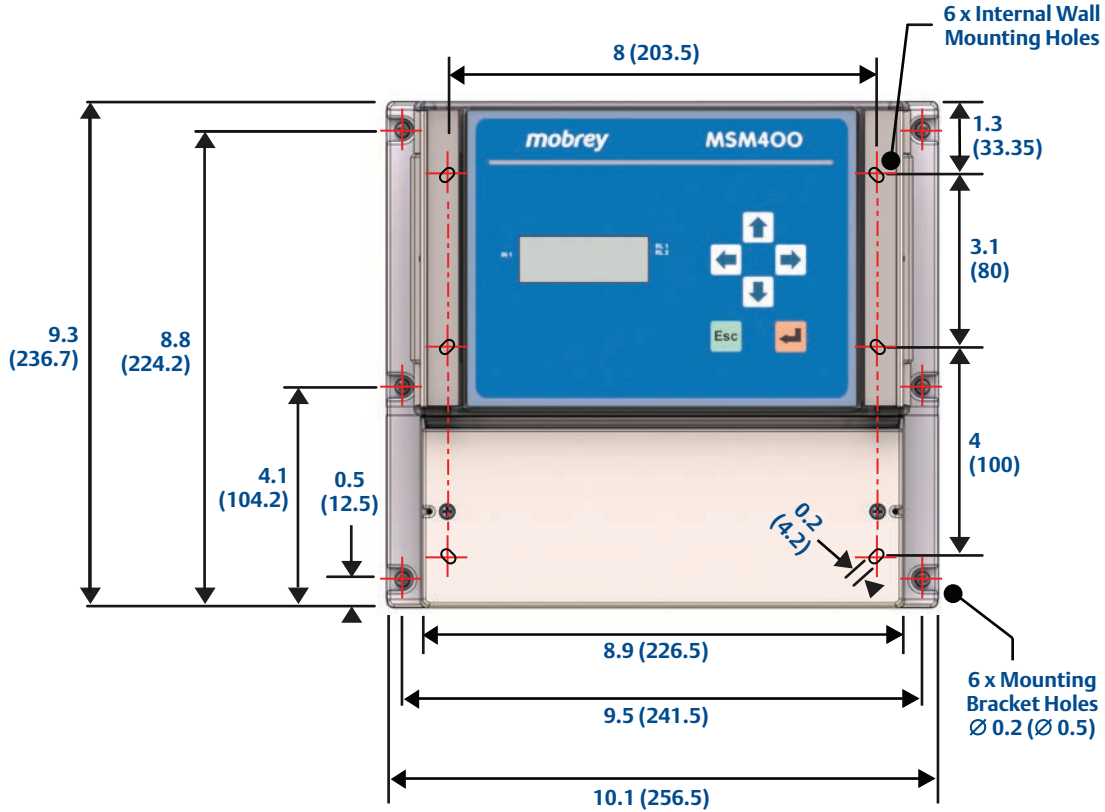

Sensors

Note: Dimensions are in inches (mm)

MSM433 In-tank Sensor

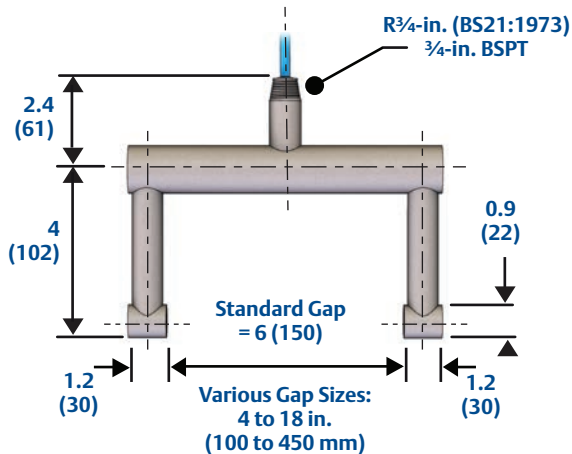

MSM448 Pipe-section Sensor

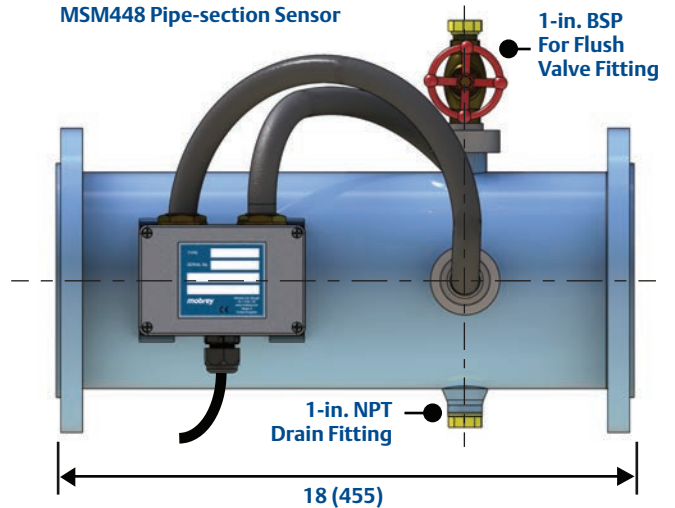









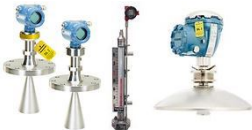



HA HIGH ACCURACY

measurement instruments

Our offering:

	<p>Pressure Measurement</p>		<p>Level Measurement</p>
	<p>Temperature Measurement</p>		<p>Flow Measurement</p>
	<p>Marine Measurement & Analytical</p>		<p>Gas Analysis</p>
	<p>Liquid Analysis</p>		<p>Flame and Gas Detection</p>
	<p>Tank Gauging</p>		<p>Wireless Infrastructure</p>
	<p>Acoustic & Discrete</p>		

www.high-accuracy.com

*The Emerson logo is a trademark and service mark of Emerson Electric Co.
Rosemount is a registered trademark of Rosemount Inc.
Mobrey is a registered trademark of Rosemount Measurement Ltd.
All other marks are the property of their respective owners.
Standard Terms and Conditions of Sale can be found at www.rosemount.com/terms_of_sale*

© 2014 Rosemount Measurement Ltd. All rights reserved.

**Emerson Process Management
Rosemount Measurement Ltd.**
158 Edinbrough Avenue,
Slough, Berks., SL1 4UE, UK
Tel +44 (0)1753 756600
Fax +44 (0)1753 823589
www.emersonprocess.com

**Emerson Process Management
Rosemount Inc.**
8200 Market Boulevard
Chanhassen, MN 55317, USA
Tel (USA) 1 800 999 9307
Tel (International) +1 952 906 8888
Fax +1 952 906 8889