



**HIGH ACCURACY**

m e a s u r e m e n t i n s t r u m e n t s

## PRODUCT DATASHEET

[www.high-accuracy.com](http://www.high-accuracy.com)

# Fan/Damper Actuators with Optional FOUNDATION™ fieldbus Communications

- Combines the power and reliability of the Hagan Pneumatic Drive with the accuracy and features of the Fisher DVC5000/6000 Digital Valve Controller
- Integral I/P: FOUNDATION™ fieldbus input or 4-20mA HART® input
- Reliable, closed loop positioning
- Double acting piston – no vanes
- Optional “fail-in-place” upon loss of plant air
- Manual operator
- ValveLink Diagnostics/AMS
- Suitable for hazardous area service; explosion-proof, flameproof or intrinsically safe



## Product description

Hagan Pneumatic Power Positioners have defined the standard of excellence in fan and damper actuation for more than 70 years.

These actuators convert the linear motion from a pneumatic piston into an 80° rotation of a drive arm. With few moving parts, the pneumatic power positioner remains the simplest, most reliable and most cost-effective method of actuation. Torque ranges are offered from 400 ft.-lbs to 4,600 ft.-lbs.

The PowerVUE design uses the same rugged Hagan actuator and frame construction, combined with the accuracy and reliability of the Fisher FieldVUE DVC5000/6000 Digital Valve Controller.

The DVC5000 controller, using the HART or FOUNDATION fieldbus communications protocols, gives easy access to information that is critical to process operation.

The controller uses feedback from the actuator travel position to diagnose not only the instrument, but the actuator as well.

The information from the DVC5000/6000 can be integrated into control systems or be received for a single loop.

These instruments use two-wire loop power for low-cost replacement of existing instruments. The two-wire design avoids cost of separate power and signal wiring.

Self-diagnostic capabilities allow you to check fan/damper actuator performance in place. You can compare the present signature (load, friction, etc.) against stored signatures to discover performance changes before they cause problems.

Field maintenance of these instruments is easy. Repair consists of quick replacement of a single master module without disconnecting wires or tubing. Troubleshooting of the master module is fast and easy in the instrument shop.

## Applications

Fan/Damper actuation for:

- Utilities
- Steel mills
- Refineries
- Pulp and paper
- Wastewater (aeration blowers)

## Theory of operation

Traditional positioners use a mechanical force/balance concept, whereby a pneumatic input signal forces a diaphragm down, actuating a valve which ports air into one side of a piston and vents the other side. A feedback spring provides a counterbalancing force as the actuator approaches setpoint.

Mechanical positioners have worked well for many years, but are subject to sticking as mechanical components become soiled, resulting in a situation where the actuator “hunts” for the proper position. The process variable is always above or below setpoint, providing poor control that costs significant money and causes excessive wear on the actuator/linkage/dampers system.

The FieldVUE DVC5000/6000 Digital Valve Controller directly receives a 4-20 mA or fieldbus input signal. An independent feedback transducer provides an actuator position input, ensuring that the PowerVUE drive always moves to the setpoint demanded by the control system. Fieldbus versions of the DVC5000/6000 also offer PID loop control capability.

## Options

**Air Lock** - mechanically locks the drive in place upon the loss of plant air.

**Manual Operator** - handwheel/lever arm permits manual adjustment of drive.

**Limit Switches** - proof of position for purge/lightoff conditions may be accomplished by traditional mechanical microswitches.

**Electric Position Transmitter** - provides a 4-20 mA feedback signal representing actuator position. (HART versions only.)

## Digital communications

### 4-20mA HART versions:

All operator information for setup and diagnostics is transmitted digitally via HART communications. A Rosemount 375 Hand-held or similar communicator may be used or a laptop computer with ValveLink Software. Emerson’s AMS offers the ValveLink software as an optional “snap-on” application. Instruments may be accessed individually or multiplexed through an “interchange” unit, providing continuous access to any number of Emerson’s instruments.

### FOUNDATION fieldbus versions:

All operator interface is via the host computer console.

A hand-held device is available.

## Valvelink advanced diagnostics

In addition to the standard features, advanced diagnostic features provide additional capabilities to diagnose problems with the DVC5000, the actuator, and even in the damper/linkage systems. Actuator can be tested as it is put into service, and this data compared to an “as found” condition after years in service. Maintenance can be scheduled based upon actual need vs. traditional “time in service” criteria.

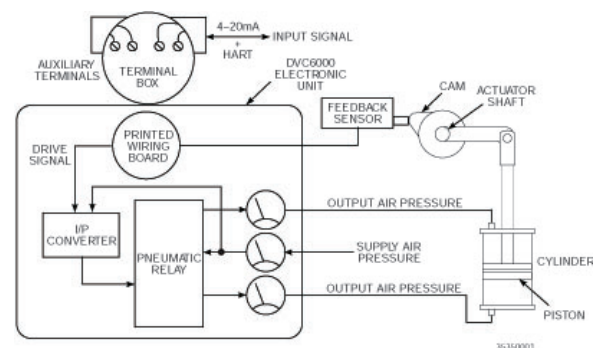
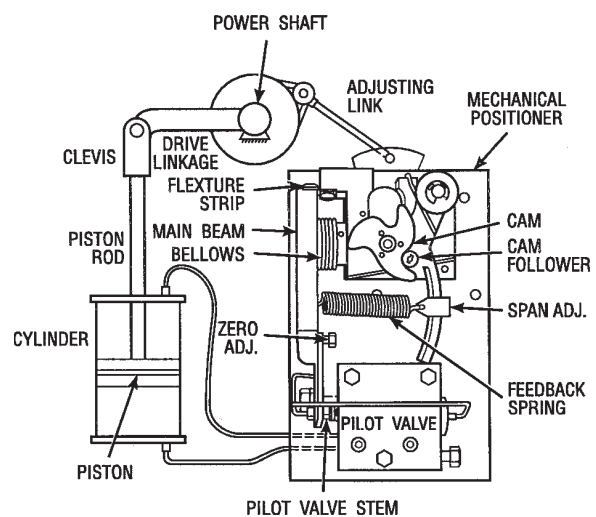

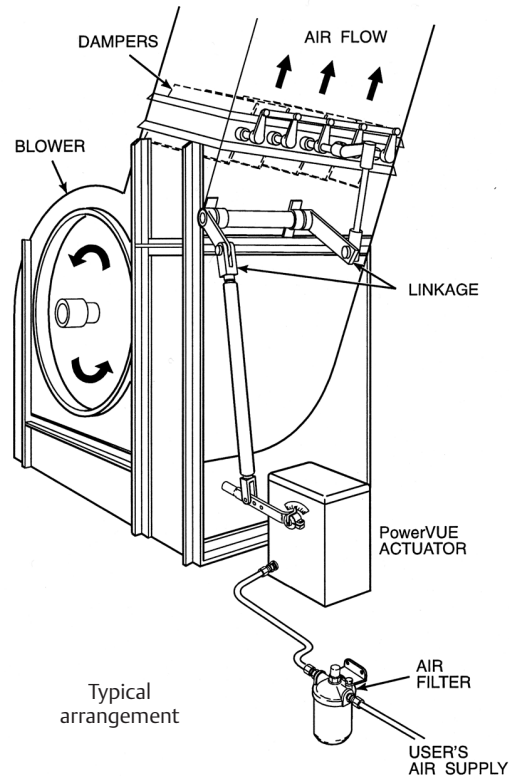

## Performance Curves

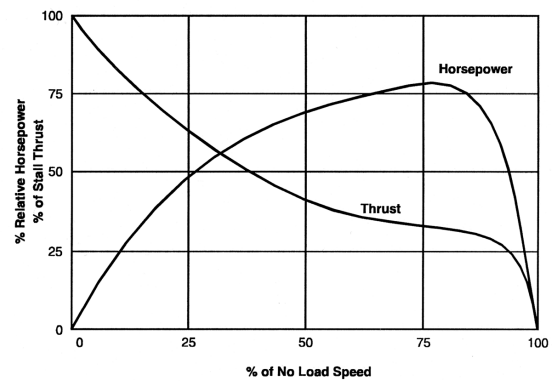
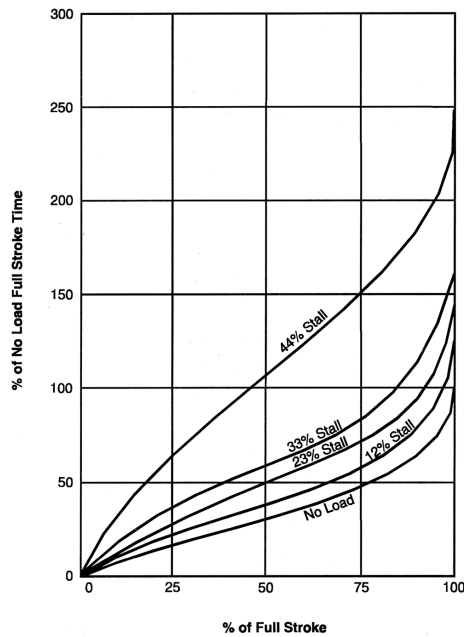

Set of characteristic curves for a typical air-operated power cylinder. Piston displacement and time are plotted for suddenly applied full-range positioning inputs to the cylinder. The linear sections of the curves correspond to steady speed.

A typical cylinder-thrust vs. speed characteristic. The curve of relative horsepower output is also shown.

Note: Stall torques are specified for all models. Emerson recommends that a 60% factor be applied to ensure fast control response. Rosemount Analytical power positioners are not recommended for reversing loads or heavy mass loads.

# 4 X 5 torque type floor mounted features, accessories and options



## Features

- Digitally-controlled positioner system with HART® or FOUNDATION™ fieldbus communications
- Repeatability better than  $\pm 0.5\%$
- Direct 4-20 mA signal input – integral I/P
- Characterizable
- Reverse or direct acting
- Standard rotation – counterclockwise

## Accessories

- Clevis and pin are included P/N 174469
- Air filter/regulator included P/N 4505C21G03

## Options

- Mechanical air lock upon loss of plant air supply
- 4-20 mA position feedback signal – 4-20 mA HART versions only
- Manual lock
- Limit switches
- Minimum limit stop

Drawings are for reference purposes only, and Rosemount Analytical Inc. does not warrant the accuracy of the dimensions herein.

Dimensions in inches with millimeters in parentheses.

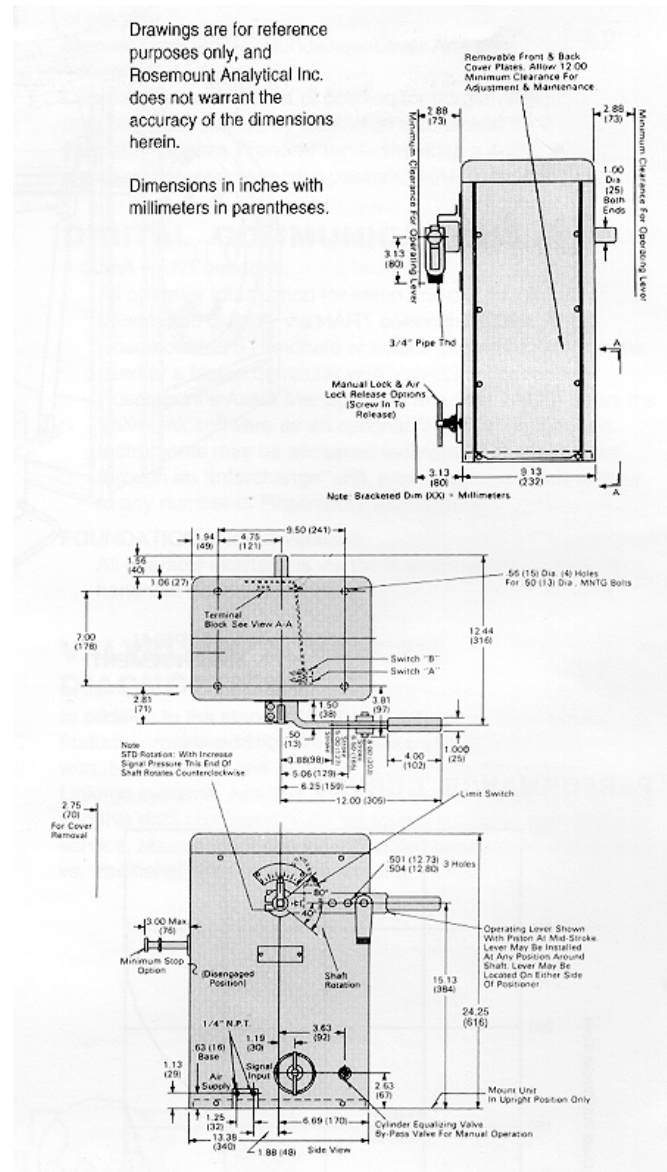

# 4 X 5 torque type floor mounted specifications<sup>1</sup>

## Specifications<sup>1</sup>

### Actuator

#### Repeatability

±0.5% of full stroke or better

#### No load full stroke time

3 sec.

#### Stall torque

400 ft.-lbs. (542 N • m) with 100 psig (689 kPa gage) air supply

#### Maximum friction load

50% of control torque.

#### Maximum weight load

140 ft.-lbs. (189 N • m)

#### Maximum allowable cylinder air pressure

100 psig (689 kPa gage)

#### Power air consumption

10 scfm steady state.

#### Stroke length

5 in. (127 mm), 80° rotation.

## Physical characteristics

#### Weight

80 lbs. (36 kg) typical

#### Air supply and signal air input fittings

1/4 inch NPT female connections

## Environmental requirements actuator

#### Ambient temperature

##### Without heater:

40° to 122°F (4,44° to 50°C), 140°F (60°C) with increased maintenance

##### With heater

-10° to 122°F (-23,3° to 50°C) 140°F (60°C) with increased maintenance

#### Relative humidity

Operable up to 100% RH

## Electronics

See DVC5000/6000 specifications

## Pneumatic

#### Operating air supply pressure

45 to 100 psig (310 to 689 kPa gage)

#### Recommended air supply pressure

100 psig (689 kPa gage)

#### Electrical Optional heater power consumption

150 watts

## Signal requirements

#### Control signal inputs

4-20 mA signal with HART® or FOUNDATION™ fieldbus

<sup>1</sup> Specifications are subject to change without notification. Our policy is one of continuous improvement, and we reserve the right to change specifications.

## Ordering information

### PVD 405 PowerVUE Drive – 4 x 5 Torque Type Floor Mount

Model	Product Description
PVD 405	PowerVUE Drive – 4 x 5 Torque Type Floor Mount
<b>Basic Assembly Type and Connection Material</b>	
01	Standard brass assembly
02	Manual lock brass assembly
03	Mechanical air lock brass assembly
04	Standard stainless assembly
05	Manual lock stainless assembly
06	Mechanical air lock stainless assembly
<b>Digital Valve Controller</b>	
00	None
01	HART®
02	Fieldbus with basic control suite
03	Fieldbus without basic control suite
04	Other DVC style selected
<b>Limit Switches</b>	
01	None
02	2 Std. limit switch – SPDT
<b>EPT</b>	
01	None
02	Digital EPT and 2 limit contacts (HART®versions only)
<b>Heater Option</b>	
01	None
02	Heater/thermostat 115V 150 watt (not for use in hazardous areas)
<b>Option Notes</b>	
General Notes	PowerVUE Drive – 4 x 5 Torque Type Floor Mount 43/95 kg/lb shipping weight Base price includes air filter-regulator. Style 4505C21G03, clevis style 174469 and IB-102-204
Level 2	Option: 00 Digital Valve Controller (DVC 5000/6000) may be supplied by others but no performance guarantees for accuracy or speed of responses are provided. Warranty for DVC 5000/6000 will be the responsibility of the provider
Level 2	Option: 02, 03 DVC 5000 Options: flameproof cable gland: 1/2" NPT (aluminum), EExd IIC; cable entry adaptor (brass): 1/2" NPT M20 x 1.5 ISO, 1/2" NPT, PG 13.5
Level 2	Option: 03 Order as separate line item from addendum price list
Level 2	Option: 03 Standard arrangement calls for Model DVC 5020F-216, certified to FM as intrinsically safe and Division II. Other certifications available. Advanced diagnostics provided.
Level 2	Option: 01 Standard arrangement calls for Model DVC 5020-116G60, certified to FM as intrinsically safe and Division II. Other certifications available. Advanced diagnostics provided
Level 2	Option: 02 Standard arrangement calls for Model DVC 5020F-216, certified to FM as intrinsically safe and Division II. Other certifications available. Advanced diagnostics provided
Level 4	Option: 02 Utilizes Moore Industries Site Programmable HART Alarm. Default configuration: 1 analog output representing actuator travel; 3 customer selectable position contacts; 1 contact for field device failure Moore HART SPA may be configured in an intrinsically safe arrangement through an IS barrier..
<b>Accessories</b>	
1101588-002ENG	Tag SS (engraved)

# 6 X 10 torque type floor mounted features, accessories and options

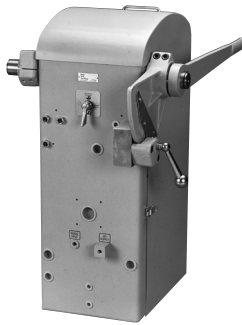

Dimensions in inches with millimeters in parentheses.

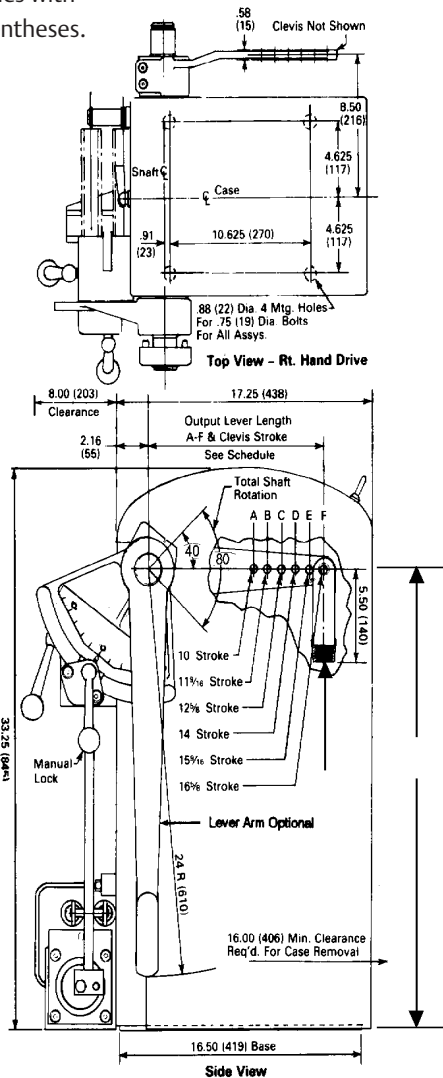

## Features

- Digitally-controlled positioner system with HART® or FOUNDATION™ fieldbus communications
- Repeatability better than  $\pm 0.5\%$
- Direct 4-20 mA signal input – integral I/P
- Characterizable
- Reverse or direct acting
- Standard rotation – counterclockwise

## Accessories

- Clevis and pin are included P/N 274472
- Air filter/regulator included P/N 274472

## Options

- Mechanical air lock upon loss of plant air supply
- 4-20 mA position feedback signal – 4-20 mA HART versions only
- Heater and thermostat
- Limit switches
- Manual operator

Drawings are for reference purposes only and Emerson does not warrant the accuracy of the dimensions herein.



## Ordering information

### PVD 610 PowerVUE Drive – 6 x 10 Torque Type Floor Mount

Model	Product Description
PVD 610	PowerVUE Drive – 6 x 10 Torque Type Floor Mount
<b>Assembly Type &amp; Connection Material</b>	
01	Manual lock, brass fittings, polymer tubing assembly
02	Manual and mechanical air lock, brass fittings, polymer tubing assembly
03	Manual lock, SS fittings, SS tubing assembly
04	Manual lock and mechanical air lock, SS fittings, SS tubing assembly
<b>DVC 6000 Controller Style</b>	
00	None required
01	HART®
02	Fieldbus with basic control suite
03	Fieldbus without basic control suite
04	Other DVC style selected
<b>Limit Switches and Position Retransmission</b>	
01	No limit switches
02	2 mechanical limit switches SPDT
03	Digital electronic position transmitter & 2 limit contacts, HART® version only
<b>Heater</b>	
01	None
02	Heater/Therostat 115 VAC 150 watt (not for use in hazardous area)
<b>Option Notes</b>	
General Notes	PowerVue Drive – 6 x 10 Torque Type Floor Mount 125/275 kg/lb shipping weight Base price includes air filter-regulator. Style 4505C21G03, clevis style 174469 and IB-102-204
Level 2	Option: 04 Designate other DVC 6000 model number as a note on order.
Level 2	Option: 00 Digital Valve Controller (DVC 6000) may be supplied by others but no performance guarantees for accuracy or speed of responses are provided. Warranty for DVC 6000 will be the responsibility of the provider.
Level 2	Option: 02, 03 DVC 6000 Options: flameproof cable gland: 1/2" NPT (aluminum), EExd IIC; cable entry adaptor (brass): 1/2" NPT M20 x 1.5 ISO, 1/2" NPT, PG 13.5
Level 2	Option: 03 order as separate line item from addendum price list.
Level 2	Option: 02 Standard arrangement calls for Model FSDVC6020F-105/G160B/CSA, certified to CSA as intrinsically safe and Division II. Other certifications available. Advanced diagnostics provided.
Level 2	Option: 01 Standard arrangement calls for Model FSDVC6030F-107/G160B/CSA, certified to CSA as intrinsically safe and Division II. Other certifications available. HC HART communications. Advanced Diagnostics option available for additional price.
<b>Accessories</b>	
1101588-002ENG	Tag SS (engraved)

## Ordering information

PVD814 PowerVUE Drive – 8 x 14 Torque Type Floor Mount

Model	Product Description
PVD814	PowerVUE Drive – 8 x 14 Torque Type Floor Mount
<b>Assembly Type &amp; Connection Material</b>	
01	Standard brass assembly
02	Standard stainless assembly
03	Mechanical air lock brass assembly
04	Mechanical air lock stainless assembly
<b>Digital Valve Controller</b>	
00	None
01	HART®
02	Fieldbus with basic control suite
03	Fieldbus without basic control suite
04	Other DVC style selected
<b>Limit Switches</b>	
01	None
02	2 Std. limit switch – SPDT
<b>Electronic Position Transmitter</b>	
01	None
02	Digital electronic position transmitter & 2 limit contacts (HART® versions only)
<b>Heater Optionr</b>	
01	None
02	Heater/thermostat 115VAC 150 watt (not for use in hazardous areas)
<b>Option Notes</b>	
General Notes	PowerVue Drive – 8 x 14 Torque Type Floor Mount 249/550 kg/lb shipping weight Base price includes air filter-regulator. Style 4505C21G03, clevis style 174469 and IB-102-204
Level 2	Option: 04 Designate other DVC 5000 model number as a note on order.
Level 2	Option: 00 Digital Valve Controller (DVC 5000/6000) may be supplied by others but no performance guarantees for accuracy or speed of responses are provided. Warranty for DVC 5000/6000 will be the responsibility of the provider.
Level 2	Option: 02, 03 DVC 5000 Options: flameproof cable gland: 1/2" NPT (aluminum), EExd IIC; cable entry adaptor (brass): 1/2" NPT M20 x 1.5 ISO, 1/2" NPT, PG 13.5
Level 2	Option: 03 order as separate line item from addendum price list.
Level 2	Option: 01 Standard arrangement calls for Model DVC5020-116G60, certified to FM as intrinsically safe and Division II. Other certifications available. Advanced diagnostics provided.
Level 2	Option: 02 Standard arrangement calls for Model DVC5020F-216, certified to FM as intrinsically safe and Division II. Other certifications available. HC HART communications. Advanced diagnostics provided.
Level 4	Option: 02 Utilizes Moore Industries Site Programmable HART Alarm. Default configuration: 1 analog output representing actuator travel; 3 customer selectable position contacts; 1 contact for field device failure. Moore HART SPA may be configured in an intrinsically safe arrangement through an IS barrier. DVC 5000 Options: flameproof cable gland: 1/2" NPT (aluminum), EExd IIC; cable entry adaptor (brass): 1/2" NPT M20 x 1.5 ISO, 1/2" NPT, PG 13.5
<b>Accessories</b>	
1101588-002ENG	Tag SS (engraved)

# DVC6000 series Specifications<sup>1</sup>

## Available configurations

### DVC6010

Sliding stem applications

### DVC6020

Rotary applications and long-stroke sliding-stem applications

### DVC6030

Quarter-turn rotary applications

## Input signal<sup>1</sup>

### Analog Input Signal

4-20 mA dc, nominal; split ranging available

### Minimum Voltage Available at Instrument Terminals

11 VDC for analog control (see instrument instruction manual for details)

### Minimum Control Current

4.0 mA

### Minimum Current without Microprocessor Restart

3.5 mA

### Maximum Voltage

30 VDC

### Overcurrent Protection

Input circuitry limits current to prevent internal damage

### Reverse Polarity Protection

No damage occurs from reversal of loop output

## Output signal<sup>1</sup>

### Ranges

Pneumatic signal as required by the actuator, up to 95% of supply pressure

### Minimum Span

6 psig (0.4 bar)

### Maximum Span

140 psig (9.5 bar)

### Action

Double, single direct, and single reverse

## Supply pressure

### Minimum and Recommended

5 psig (0.3 bar) higher than maximum actuator requirements

### Maximum

150 psig (10.2 bar) or maximum pressure rating of the actuator, whichever is lower

## Steady-state air consumption<sup>1 2 3</sup>

### At 20 psig (1.4 bar) supply pressure

Less than 11 scfh (0.3 normal m<sup>3</sup>/hr.)

### At 100 psig (6.9 bar) supply pressure

Less than 45 scfh (1.2 normal m<sup>3</sup>/hr.)

### Xi Temp. limits as measured inside the electronics housing

-20° to 70°C (-4° to 158°F)

## Maximum output capacity<sup>2 3</sup>

### At 20 psig (1.4 bar) supply pressure

465 scfh (12.5 normal m<sup>3</sup>/hr.)

### At 100 psig (6.9 bar) supply pressure

1570 scfh (42.1 normal m<sup>3</sup>/hr.)

## Independent linearity<sup>1</sup>

±0.5% of output span

## Electrical classification

### Hazardous Area

FM, CSA, CENELEC

Other approvals are pending from certifying agencies

### Electrical Housing

Designed to meet NEMA 4X, IEC 529 IP 65

## Connections

### Supply Pressure

1/4-inch NPT female and integral pad for mounting  
67 CFR regulator

### Output Pressure

1/4-inch NPT female

### Tubing

3/8-inch metal, recommended

### Vent (pipe-away)

1/4-inch NPT female

### Electrical

1/2-inch NPT female conduit connection,  
M20 adaptor optional

## DVC6000 series Specifications<sup>1</sup> continued

### Operating ambient temperature limits (standard)

-40° to 85°C (-40° to 185°F)

### Construction materials

#### Housing, module base and terminal box

ANSI B360.0 low copper aluminum alloy

#### Cover

Valox

#### Elastomers

Nitrile (standard), or Fluorelastomer (optional)

### Stem travel

#### DVC6010

0 to 102 mm (8-1/8 inches) maximum

0 to 19 mm (3/4 inches) minimum

#### DVC6020

0 to 22 inches

### Shaft rotation (DVC6020 and DVC6030)

0 to 90 degrees maximum.

### Mounting

Designed for direct actuator mounting. For weatherproof housing capability, the instrument must be mounted upright to allow the vent to drain.

### Weight

3.5 kg (7.7 lbs.)

### Options

Supply and output pressure gauges or tire valves  
Integrally mounted filter regulator

<sup>1</sup> These terms are defined in ISA Standard S51.1-1979

<sup>2</sup> Normal m<sup>3</sup>/hr. – Normal cubic meters per hour at 0°C and 1.01325 bar, absolute; Scfh-Standard cubic feet per hour at 80°F and 14.7 psia

<sup>3</sup> Values at 1.4 bar (20 psig) based on a single-acting relay; values at 6.8 bar (100 psig) based on double-acting relay.



Emerson Process Management has satisfied all obligations coming from the European legislation to harmonize the product requirements in Europe. The PowerVUE actuator is a subcomponent of an actuating system, including user-provided items such as linkages, bearings, and dampers. The user must ensure that the entire actuating system is in conformity with the provisions of the European Machinery Directive EC Machinery Directive 89/392/EEC, as amended by directive 91/368/EEC and Directive 93/44/EEC.

# PowerVue field retrofit kits for existing Hagan power positioners

## Description

An existing Hagan torque-type power positioner can be retrofitted with the PowerVUE system in a few hours.

The PowerVUE system eliminates most maintenance requirements associated with mechanical “force balance” positioning systems, based on pilot valves.

The Hagan PowerVUE retrofit package includes all mounting brackets, hardware, and pneumatic tubing needed to upgrade an existing Hagan Pneumatic Power Positioner. No drilling or tapping of holes is required. (The positioning system mounts directly to the frame, eliminating the need for connecting linkages.)

Note: Retrofit kits are not offered for the Hagan thrust-type units, or the Econotorque Models.

## Features

- Digitally-controlled positioner system
- Factory designed mounting
- Direct 4-20 mA signal input – integral I/P
- Characterizable
- Air lock upon loss of plant air supply
- Reverse or direct acting
- ValveLink diagnostics

## Options

- 4-20 mA position feedback signal
- 2 position limit contacts available

Field Retrofit Kits are available for the 4 x 5 and 8 x 14 torque-type models:

PP405TR	4” x 5”	Cylinder
452167	8” x 14”	Cylinder
457696	8” x 14”	Cylinder
452593	8” x 14”	Cylinder
443700	8” x 14”	Cylinder
457031	8” x 14”	Cylinder

## Ease of retrofit

(4 x 5 Unit Pictured)

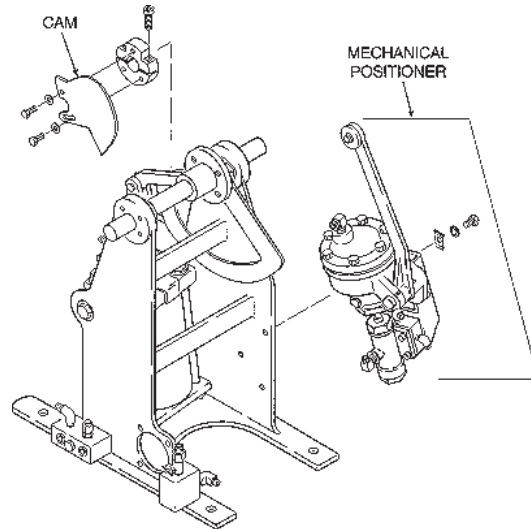

Step #1 – remove existing positioning system

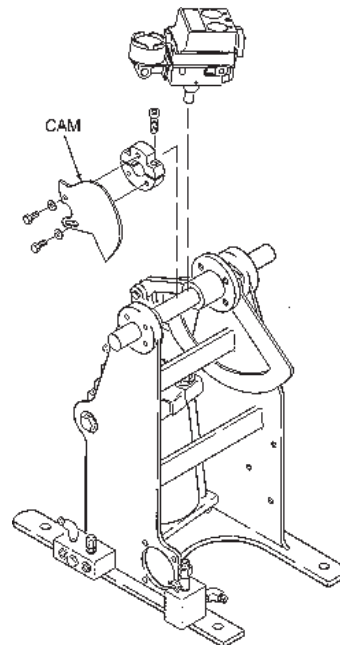

Step #2 – install PowerVue DVC5000 components

## Ordering information

PVD 468R PowerVUE Drive – Retrofit Kit 4x5 or 8x14













Model	Product Description
PVD 468R	PowerVUE Drive – Retrofit Kit 4x5 or 8x14
Model	
00	4x5
01	8x14
03	6x10
Digital Valve Controller	
00	None required
01	HART®
02	FieldBus with basic control suite
03	FieldBus without basic control suite
04	Other DVC style selected, see addendum
Electronic Position Transmitter	
00	None required
01	Digital electronic position transmitter & 2 limit contacts, HART® version only (4)
Option Notes	
General Notes	<p>PowerVue Drive – Retrofit Kit 4x5 or 8x14                      “Base price includes air filter/regular style: 4505C21G03; clevis style: 174469                      Instruction manual IB 102-204.</p> <p>“Performance specifications may vary from the published specifications, depending on the age of the existing Hagan fan/damper actuator and the quality of the DVC 5000/6000 installation. Setup and calibration of DVC 5000 is responsibility of others. Fairchild reversing relay is included with or without selection of DVC 5000.”</p>
Level 1	<p>Option: 02                      Some drilling and tapping required. Existing covers may be modified in the field or a precut back cover can be selected, P/N 4851B28G01.</p>
Level 2	<p>Option: 04                      Designate other DVC 5020/6020 model number as a note on order.</p>
Level 2	<p>Option: 00                      Digital Valve Control (DVC 5000/6000) may be supplied by others, but no performance guarantees for accuracy or speed of response are provided. Warranty for DVC 5000/6000 will be the responsibility of the provider. Tubing is provided, but is not precut or preformed.</p>
Level 2	<p>Option: 02, 03                      DVC 5000 Options: flameproof cable gland: 1/2" NPT (aluminum), EExd IIC, cable entry adaptor (brass): 1/2" NPT M20 x 1.5 ISO, 1/2" NPT, PG 13.5.</p>
Level 2	<p>Option: 03                      Order as separate line item from addendum price list.</p>
Level 2	<p>Option: 01                      Standard arrangement calls for Model DVC5020-116G60, certified to FM as intrinsically safe, and Division II. Other certifications available. Advanced diagnostics provided.</p>
Level 2	<p>Option: 02                      Standard arrangement calls for model DVC5020F-216, certified to FM as intrinsically safe, and Division II. Other certifications available. Advanced diagnostics provided.</p>
Option Notes	
1101588-002ENG	Tag SS (engraved)



# HA HIGH ACCURACY

measurement instruments

Our offering:

 <p>Pressure Measurement</p>	 <p>Level Measurement</p>
 <p>Temperature Measurement</p>	 <p>Flow Measurement</p>
 <p>Marine Measurement &amp; Analytical</p>	 <p>Gas Analysis</p>
 <p>Liquid Analysis</p>	 <p>Flame and Gas Detection</p>
 <p>Tank Gauging</p>	 <p>Wireless Infrastructure</p>
 <p>Acoustic &amp; Discrete</p>	 <p>HA HIGH ACCURACY measurement instruments</p>

[www.high-accuracy.com](http://www.high-accuracy.com)

<http://www.EmersonProcess.com>

 <http://www.analyticexpert.com>

 <http://twitter.com/RAIhome.com>

**Rosemount Analytical**  
Headquarters & Liquid Analytical  
2400 Barranca Parkway  
Irvine, CA 92606  
United States  
Phone: 1.800.854.8257  
Fax: 1.949.474.7250

**Rosemount Analytical**  
Gas Chromatographs & Service Center  
5650 Brittmoore Road  
Houston, Texas 77041  
United States  
Phone: 1.866.422.3683  
Fax: 1.713.827.3865

**Rosemount Analytical**  
Process Gas & Combustion Center  
6565-P Davis Industrial Pkwy  
Solon, OH 44139  
United States  
Phone: 1.800.433.6076  
Fax: 1.440.914.1262

**Rosemount Analytical – Latin America**  
Emerson Process Management  
Analytical Division  
111000 Brittmoore Park Drive  
Houston, TX 77041  
Phone: 1.713.467.6000  
Fax 1.713.827.3329

**Rosemount Analytical - Europe**  
Emerson Process Management Services Ltd.  
Analytical Division  
Blegistrasse 21  
PO Box 1046  
CH 6341 Baar  
Switzerland  
Phone: 41.41.768.6111  
Fax: 41.41.761.8740

**Rosemount Analytical – Asia Pacific**  
Emerson Process Management  
Analytical Division  
Asia Pacific Private Ltd.  
1 Pandan Crescent  
Singapore 128461  
Republic of Singapore  
Phone: 65.6.777.8211  
Fax: 65.6.777.0947

Scan this QR code to  
open the Model 6888  
product information  
web page.



© 2011 Emerson Process Management. All rights reserved.

The Emerson logo is a trademark and service mark of Emerson Electric Co. Brand name is a mark of one of the Emerson Process Management family of companies. All other marks are the property of their respective owners.

The contents of this publication are presented for information purposes only, and while effort has been made to ensure their accuracy, they are not to be construed as warranties or guarantees, express or implied, regarding the products or services described herein or their use or applicability. All sales are governed by our terms and conditions, which are available on request. We reserve the right to modify or improve the designs or specifications of our products at any time without notice.