



HIGH ACCURACY

m e a s u r e m e n t i n s t r u m e n t s

PRODUCT DATASHEET

www.high-accuracy.com

Rosemount TGU 53

Tank Radar Gauge, Still Pipe Antenna for LNG



The Rosemount TGU 53 Tank Radar Gauge, Still Pipe Antenna for LNG measures level, temperature and pressure in liquefied gas tanks and is part of the Rosemount Custody Transfer System. It is an intrinsically safe tank radar intended to be mounted on ships deck. The radar transmission is guided through a full length still pipe measuring the surface of the product. Using our reliable method, the signals are digitally processed to achieve a very accurate reading of the distance to the surface.

By using our patented uniquely technologies, two radar measurements can be done separately and independently from each other in the one and same gauge. One radar measurement channel can be chosen with possibility to upgrade to dual channel configuration.

- The most accurate and reliable level measurement from the pioneers in radar level gauging and LNG CTS systems
- All electronics are outside the tank, integrated under one cover
- Patented Array Attenuator enables measurement close to tank bottom
- Dual channel measurement with one Tank Gauge Unit and one Still Pipe, enabling Primary and Secondary CTS with less hardware
- The TGU 53 is an integrated part of the Rosemount Custody Transfer System
- Factory Acceptance Tested using Moveable Echo to simulate any liquid level in tank

Description

The Rosemount TGU 53 Tank Radar Gauge is suited for installation on LNG and LPG tanks. The unit is equipped with a cone antenna and measures the level of the liquefied gas in a still pipe.

The TGU 53 incorporates measurement of level, temperature and pressure in the same integrated unit. All electronics can be exchanged from the deck without opening the tank to atmosphere.

The gauge is intrinsically safe and operates based on 10 GHz FMCW radar technology.

Connections

One digital bus connection to the Rosemount SCU 51 Supply and Communication Unit per level measurement channel.

Still Pipe and in-tank Installation

The complete still pipe assembly consists of a gauge socket, joined still pipe segments with equalizing holes and a verification pin. Two vented thermowells run alongside the radar still pipe and in these the temperature sensors are inserted.

Brackets for securing the still pipe and the thermowells to the pump tower structure are used in accordance with the appropriate tank engineering practice and are included with the equipment.

The array attenuator is a patented device located below the still pipe for absorbing the microwave reflection from the tank bottom. This enables level measurement with very low liquid levels in the tank.

Dual Channel Measurement

One TGU 53 can measure two levels independently using separate electronic boards, connected to the same antenna and with the same still pipe. This enables Primary and Secondary CTS levels to be measured with only one single still pipe installation in a tank.



Tank Installation Overview

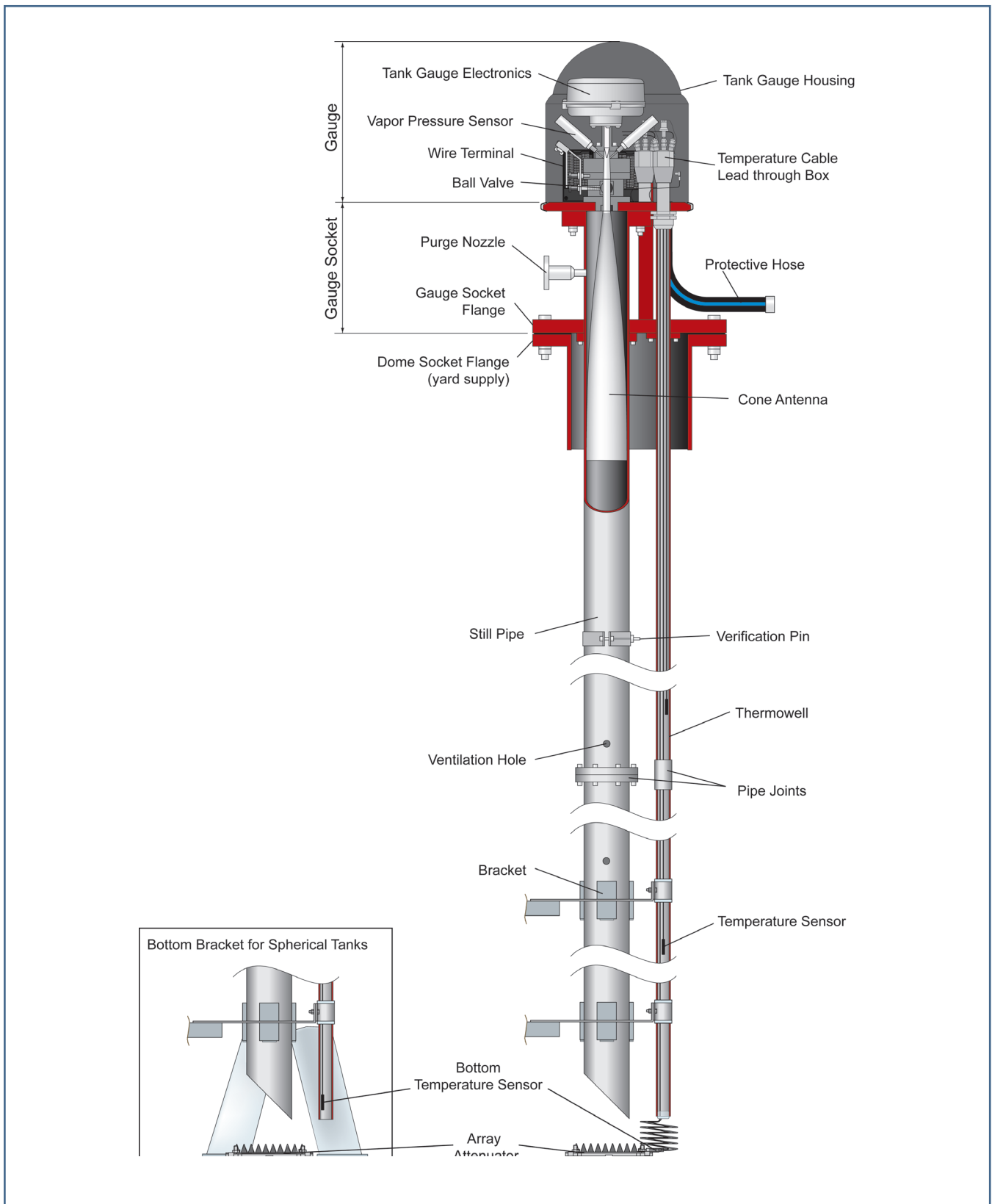

Dimensional Drawings

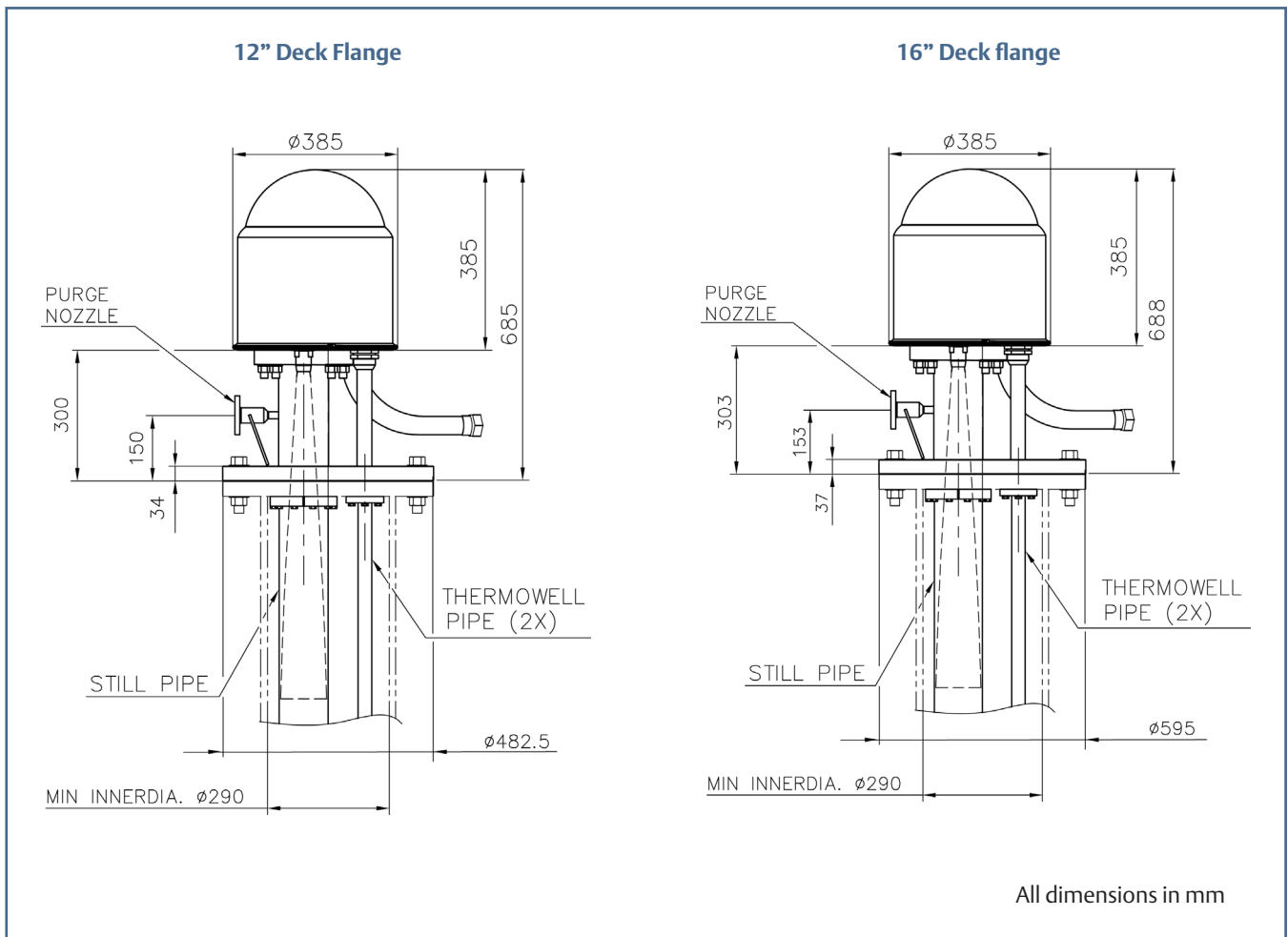

Technical Specification

TGU 53		
General Specification		
Antenna type	Cone Antenna with Still Pipe	
Product Range	Liquefied gases according to IMO IGC code	
Measuring range	0 to 52 m	
Instrument accuracy	± 3 mm	
Lowest measurable level	26 mm above bottom of array attenuator PTFE plate	
Number of radar channels	One or two	
FMCW centre frequency	10 GHz	
Operating temperature, tank	-170 to +100 °C	
Operating pressure, tank	0.8 to 8 Bar (absolute)	
Electrical Specification		
Cable to control room	Up to 2 cables with up to three twisted pairs with common shield	
Number of cable inlets	1 to 2	
Cable diameters	6 to 21 mm	
Field bus	Proprietary intrinsically safe	
Microwave output power	<1 mW	
Mechanical Specification		
Weight	33 kg	
Material facing tank atmosphere	Stainless steel 304L, 316L, PTFE (PolyTetraFluoroEthylene)	
Material facing deck	Stainless steel 316, 316L	
Deck Socket		
Deck flange dimensions	12" and 16"	
Material	Stainless steel 316, 316L	
Weight	58 kg (12") or 89 kg (16")	
Purge Nozzle	Flange ANSI 1/2"	
Still Pipe		
Spherical Tanks	Dimension	Ø 114.3 T 4, extending throughout the full height of the tank, up to 6 m segments
	Material	Aluminium 5083-0
Membrane Tanks	Dimension	Ø 114.3 T 3.6, extending throughout the full height of the tank, up to 6 m segments
	Material	Stainless steel 304L

TGU 53		
Thermowell		
Spherical Tanks	Dimension	Ø 34 T 3, extending throughout the full height of the tank, up to 6 m segments
	Material	Aluminium 5083-0
Membrane Tanks	Dimension	Ø 33.4 T 2.77, extending throughout the full height of the tank, up to 6 m segments
	Material	Stainless steel 304L
Bracket		
Installation	Bracket is permanently welded to pump tower structure	
Usage	Allows Still Pipe and Thermowell to move vertically due to thermal expansion	
Material, Bracket	Stainless Steel 304 or Aluminium 5083-0	
Material, Gliding Guides	UHMW PE (UltraHigh Molecular Weight PolyEthylene)	
Verification Pin		
Installation	Verification pin installed through still pipe above highest measurable level	
Usage	Allows periodic verification of TGU 53	
Material	Stainless steel 304L	
Array Attenuator		
Installation	Below still pipe, either welded on tank bottom or attached to pump tower structure	
Usage	Allows radar to measure as low liquid levels as possible without signal interference from tank bottom echo	
Material, Plate	Stainless Steel 304 or Aluminium 5083-0	
Material, Array Attenuator	PTFE (PolyTetraFluoroEthylene)	
Vapor Pressure Measurement		
Installation	Inside TGU 53 housing	
Number of pressure sensors	One or two	
Vapor Pressure sensor for LNG	Range	0.8 to 2 Bar (absolute)
	Accuracy	± 3 mbar
Vapor Pressure sensor for LPG	Range	0.8 to 8 Bar (absolute)
	Accuracy	± 15 mbar
Temperature Measurement		
Installation	Inside TGU 53 housing	
Number of temperature electronics	One or two	
Number of temperature sensors	1 - 6 per temperature electronics	
Temperature sensor type	4-wire Pt 100 RTD's, individually calibrated	
Temperature range	-165 to +100 °C	
Temperature system accuracy	± 0.2 °C	









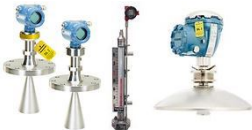

TGU 53		
Environment Specification		
Ingress protection	IP66	
Ambient temperature	-40 to +70 °C	
Humidity	0 - 100 %	
Approvals		
Marine approvals	ABS, BV, CCS, DNV-GL, KR, LR, NK, RINA	
Explosion protection	Intrinsically safe	ATEX:  II 1 G Ex ia IIC T4 IECEX: Ex ia IIC T4 Ga



HIGH ACCURACY

measurement instruments

Our offering:

	<p>Pressure Measurement</p>		<p>Level Measurement</p>
	<p>Temperature Measurement</p>		<p>Flow Measurement</p>
	<p>Marine Measurement & Analytical</p>		<p>Gas Analysis</p>
	<p>Liquid Analysis</p>		<p>Flame and Gas Detection</p>
	<p>Tank Gauging</p>		<p>Wireless Infrastructure</p>
	<p>Acoustic & Discrete</p>		

www.high-accuracy.com

©2016 Emerson. All rights reserved.

The Emerson logo is a trademark and service mark of Emerson Electric Co. Rosemount and the Rosemount logotype are registered trademarks of Rosemount Inc. TankRadar is a trademark of Rosemount Tank Radar AB. Rosemount Tank Radar AB is a member of the Emerson family of companies. All other marks are the property of their respective owners.

Emerson Automation Solutions

Rosemount Tank Radar AB
Box 150
SE-435 23 Mölnlycke
T +46 31 337 00 00
F +46 31 25 30 22

www.Emerson.com/marine

The contents of this publication are presented for information purposes only, and while effort has been made to ensure their accuracy, they are not to be construed as warranties or guarantees, expressed or implied, regarding the products or services described herein or their use or applicability. Standard Terms and Conditions of Sale can be issued by contacting Rosemount Tank Radar AB. We reserve the right to modify or improve the designs and specifications of our products at any time without notice. Rosemount Tank Radar AB accepts no responsibility for any errors that may appear in this publication.

