



HIGH ACCURACY

m e a s u r e m e n t i n s t r u m e n t s

PRODUCT DATASHEET

www.high-accuracy.com

Rosemount TGU 65

Tank Radar Gauge, Still Pipe Antenna

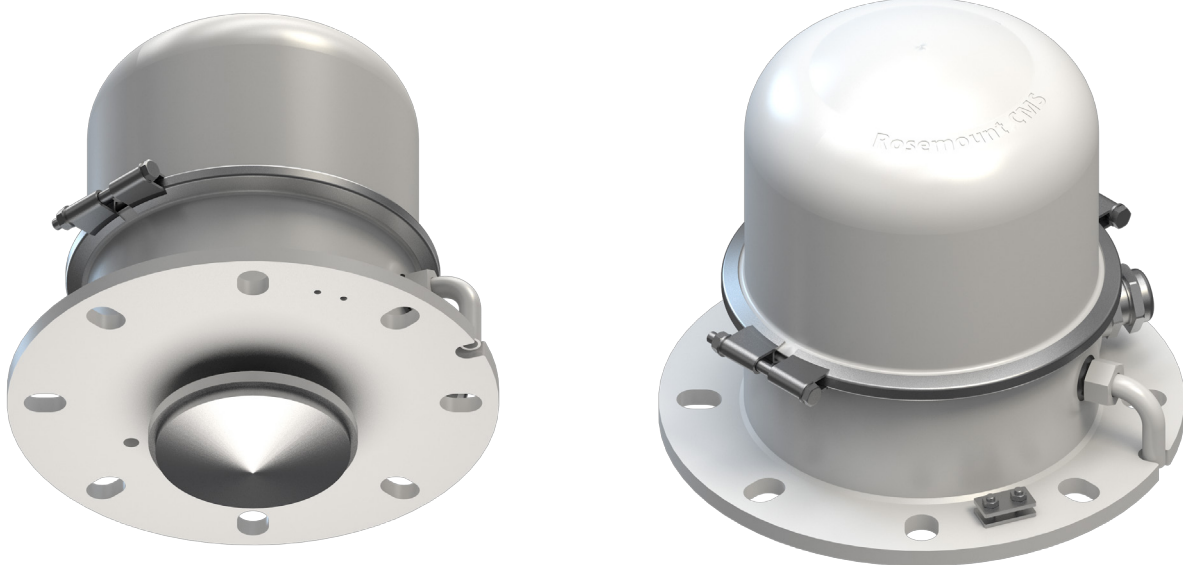

Rosemount TGU 65 Tank Radar Gauge, Still Pipe Antenna is a marine pipe guided level gauge that is integrated in the Rosemount Cargo Monitoring System (CMS). It is designed to be used in harsh conditions on tankers and offshore installations, and has a superior robustness and accuracy under all tank conditions.

Rosemount TGU 65 Tank Radar Gauge, Still Pipe Antenna comes in two versions. The TGU 65C is the best choice for measuring ullage on tankers and marine applications, and the TGU 65S is ideal for offshore market needs.

TGU 65 can have up to two independent measurement channels in the same unit.

- Ideal solution for measuring ullage in narrow tanks
- Accurate measurement of sea water draft
- Reliable measurement that keeps you operating under adverse conditions in tank
- Robust, withstands harsh conditions on deck
- Easy to install, light weight
- 10 GHz FMCW tank radar gauge, with still pipe antenna and low-loss mode to withstand build up and deposits inside the pipe
- Optional integrated vapor pressure sensor
- Optional level redundancy measurements
- Optional independent high level alarm measurements

Description

TGU 65

The Rosemount TGU 65 Tank Radar Gauge, Still Pipe Antenna, is suited for installation on general tanks with a tank height of up to 35 meter. The unit is equipped with an array antenna, and shall be mounted in a 5" or 6" still pipe. The signal processing and special low-loss mode keeps the TGU 65 operating even if deposits build up inside the pipe.

The gauge is intrinsically safe and operates based on 10 GHz FMCW radar technology.

TGU 65C

The TGU 65C is the ideal choice for measuring ullage in narrow slop tanks and residual tanks on tankers and marine applications, where it can be difficult to find free space for the TGU 68C.

TGU 65S

The TGU 65S fits the offshore market needs for narrow tanks and sea water draft applications. The TGU 65S has a wider range of options available than the TGU 65C, such as an extended range for up to 65 m.

Connections

One digital bus connection to the Rosemount SCU 51 Supply and Communication Unit in the control room per level measurement channel.

Optional digital bus connections to:

- Rosemount TMU 51/53 Temperature Measuring Units
- Rosemount TGD 51 Tank Gauge Display
- Rosemount WTU 51 Tank Cleaning Monitoring

Vapor Pressure Option

An optional vapor pressure sensor can be mounted as an integrated part inside the TGU 65. The vapor pressure sensor provides the relative pressure inside the tank.

Redundancy and High Level / Overfill Options

The gauge is as standard equipped for level measurements, but is prepared for optional redundant level or independent high level or overfill alarm measurements.

Rosemount Cargo Monitoring System

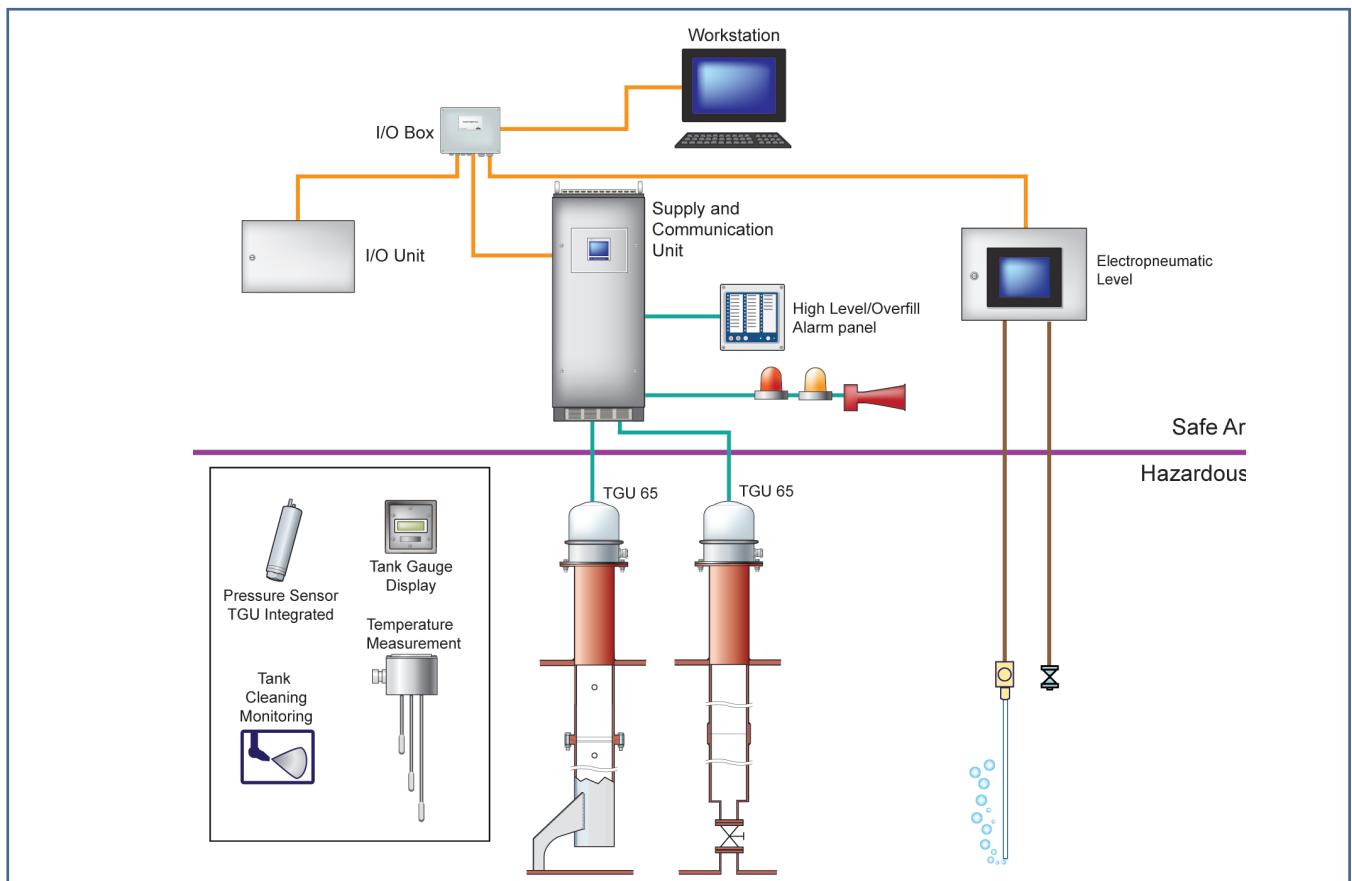

Still Pipe

The Rosemount TGU 65, Tank Radar Gauge Still Pipe Antenna needs a pipe to guide the microwave signal. The pipe can either be a 5” or a 6” pipe, and they are normally yard supplied. The still pipe needs to have venting holes to allow level to equalize between still pipe and tank. The manufacturing method for the pipe can either be:

- A. Flanged pipe segments joined together by bolt and nut
- B. Pipe segments welded together butt to butt
- C. Pipe segments welded together with a sleeve

Radar Principles

The FMCW radar used in Rosemount CMS emits radar waves continuously at a known range of frequencies. The transmitted radar frequency is increased over a time creating a sweep. The reflected signals is then mixed with the transmitted signals creating a low frequency signal that is proportional to the product level. The signals are digitally processed and presents a very accurate reading of the distance to the product level.

The main advantages for using radar for tank gauging are:

- Radar waves are extremely robust to any conditions in the tank
- Radar waves are generally not affected by the atmosphere above the product in the tank
- The only part located inside the tank is the antenna without any moving parts
- High reliability
- High accuracy
- With Rosemount CMS, the Tank Gauge Electronics can easily be serviced and replaced during closed tank conditions.

The radar wave propagates inside the still pipe with a special polarized, low-loss mode making it less sensitive to deposits and contamination inside the pipe. Even so, for the best measurement performance, it is important that the inside of the still pipe is smooth and without irregularities.

The lower end of the pipe will end over the tank bottom in case of tank ullage measurement. For draft installations the pipe enters the sea water with a yard supplied sea valve.

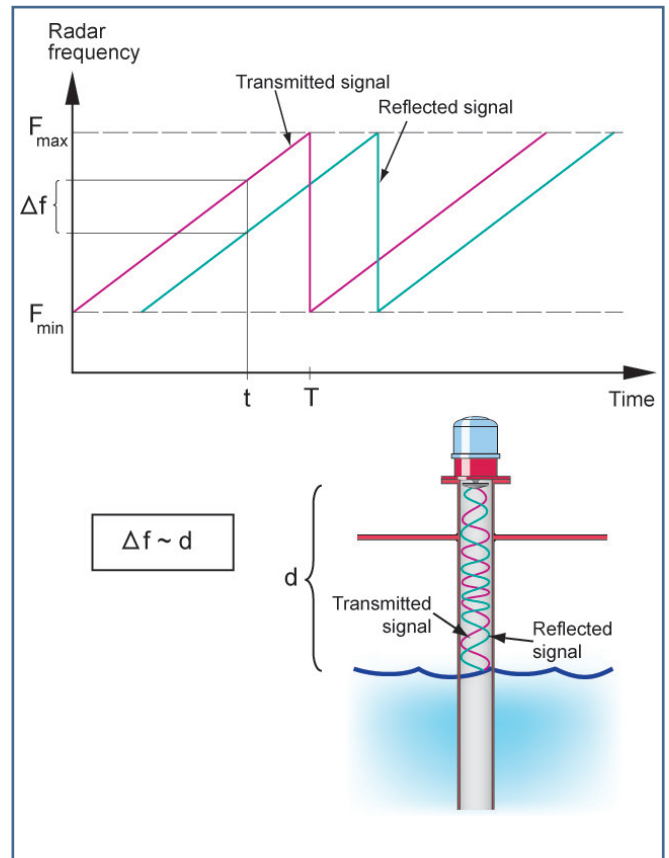

Technical Specification

TGU 65	
General Specification	
Antenna type	Array antenna for installation on still pipe
Measuring range	0 to 35 m standard 0 to 65 m for TGU 65S ¹
Instrument accuracy	±2 mm ²
FMCW centre frequency	10 GHz
Operating temperature in tank	-40 to +100° C
Operating pressure in tank	-100 to +500 mbar
Still Pipe and Deck Socket	
Still pipe and deck socket	Yard supply
Still pipe dimension	Inner diameter between 5" Array antenna: 124.5 and 134.5 mm 6" Array antenna: 150.3 and 161.5 mm
Still pipe venting	Vented pipe for tank level equalization
Still pipe material	Metallic, according to yard specification. Typically stainless or carbon steel.
Tank installation	Still pipe ends maximum 250 mm from bottom
Draft installation	Sea water valve (yard supply)
Deck socket	Minimum 900 mm extension of still pipe from deck
Electrical Specification	
Cable to control room	Up to 3 cables with two or three twisted pairs with common shield Max length approximately 400 m
Number of cable inlets	1 to 3
Cable diameters	6 to 21 mm
Field bus	Proprietary intrinsically safe
Microwave output power	<1mW
Mechanical Specification	
Flange	Suitable for mounting on JIS 5K-200, DN200, ASME 8", DN 250
Weight	17 kg (35 lbs.)
Material facing tank atmosphere	Stainless steel 316L, PTFE, Fluorsilicone (standard)
Material facing deck	Stainless steel 316L
Environment Specification	
Ingress protection	IP 66/67
Ambient temperature	-40 to +70° C
Humidity	0 - 100% relative humidity
Vapor Pressure Option	
Operating range	-100 to 900 mbar
Instrument accuracy	±3 mbar
Material facing tank atmosphere	Stainless steel 316L and Alloy C276

1) Maximum range depending on application

2) Operational accuracy in still pipe (typical) ±10 mm. Undefined accuracy below end of still pipe.

TGU 65		
Approvals		
Marine type approvals	ABS, BV, CCS, DNV-GL, KR, LR, NK, RINA	
Explosion protection	Intrinsically safe:	ATEX:  II 1G Ex ia IIC T4 Ga, IECEx: Ex ia IIC T4 Ga INMETRO: Ex ia IIC T4 Ga

Ordering Information

Ordering Information	TGU 65C	TGU 65S	Comments
Flange			
Housing, flange JIS 200A / EN DN200	√	√	
Housing flange EN DN 250	√	√	
Housing, flange ASME B16.5 8"		√	
Gasket Material			
O-ring, fluorsilicone	√	√	
Customer Pipe			
5 in. / DN 125 Pipe (for antenna ø 120 mm)	√	√	
6 in. / DN 150 Pipe (for antenna ø 145 mm)	√	√	
Vapor Pressure Sensor			
Vapor Pressure Sensor, -100 to 900mBar	√	√	Option
Measuring Channels			
Tank Gauge Electronics box 10 GHz, 1 channel	√	√	
Tank Gauge Electronics box 10 GHz, 2 channels	√	√	
Hazardous Locations Certification			
ATEX, IECEx Intrinsic Safety TGU 65	√	√	
INMETRO, Intrinsic Safety TGU 65		√	
Cable Glands			
Cable gland M20	√	√	Option 1-3 glands
Cable gland M25	√	√	Option 1-3 glands
Cable gland M32	√	√	Option 1-3 glands
Special		√	Option 1-3 glands
Optional Items			
Protective hose for Cable Gland	√	√	Option
Flange JIS 5K 40A for Protective hose	√	√	Option
Flange JIS 5K 50A for Protective hose	√	√	Option
Flange PN10 DN40 for Protective hose	√	√	Option
Bolt Kit (gauge socket)	√	√	Option
Gasket (gauge socket)	√	√	Option
Metal label (TAG plate)		√	Option
Calibration certificate		√	Option
Material traceability certification acc. to EN 10204.3		√	Option
Extended measurement range		√	Option

√ = Available

Dimensional Drawings

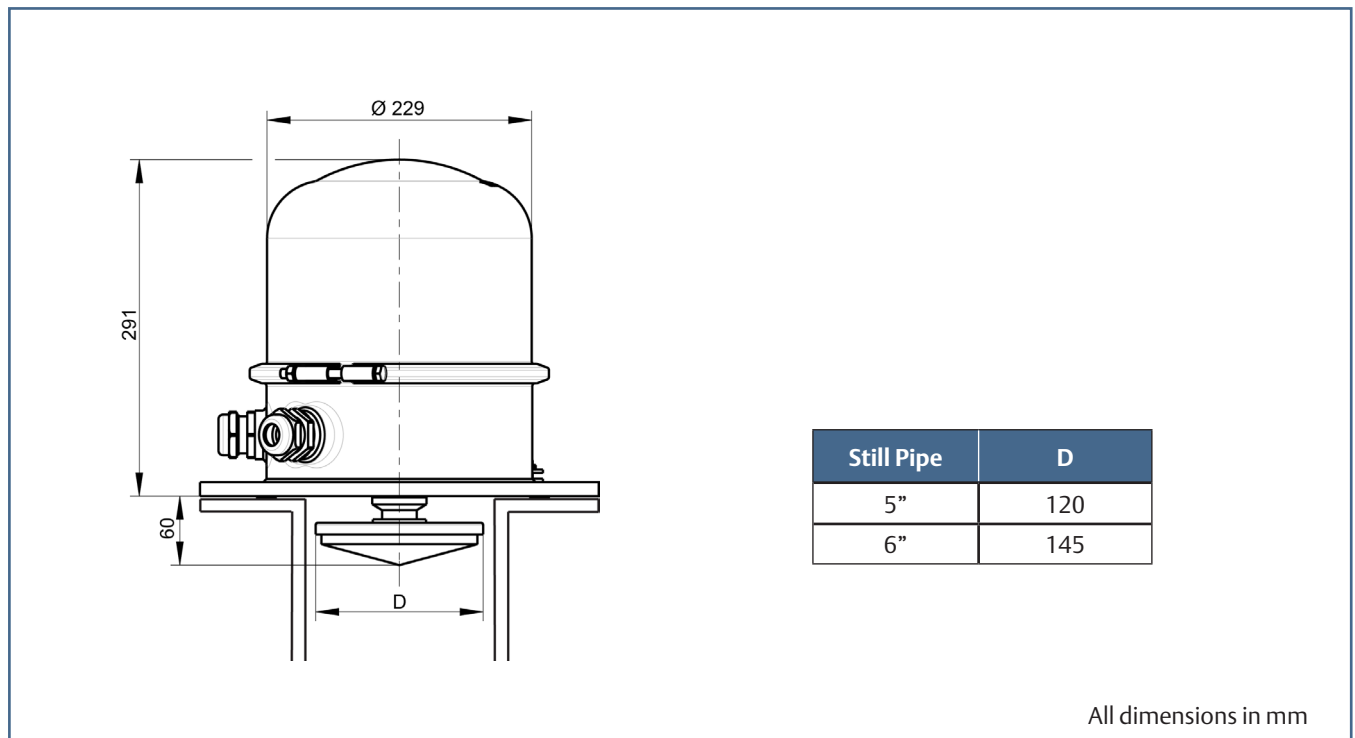

©2016 Emerson Automation Solutions. All rights reserved.

The Emerson logo is a trademark and service mark of Emerson Electric Co. Rosemount and the Rosemount logotype are registered trademarks of Rosemount Inc. TankRadar is a trademark of Rosemount Tank Radar AB. Rosemount Tank Radar AB is a member of the Emerson family of companies. All other marks are the property of their respective owners.

Emerson Automation Solutions

Rosemount Tank Radar AB
Box 150
SE-435 23 Mölnlycke
T +46 31 337 00 00
F +46 31 25 30 22

www.Emerson.com/marine













The contents of this publication are presented for information purposes only, and while effort has been made to ensure their accuracy, they are not to be construed as warranties or guarantees, expressed or implied, regarding the products or services described herein or their use or applicability. Standard Terms and Conditions of Sale can be issued by contacting Rosemount Tank Radar AB. We reserve the right to modify or improve the designs and specifications of our products at any time without notice. Rosemount Tank Radar AB accepts no responsibility for any errors that may appear in this publication.



HIGH ACCURACY

measurement instruments

Our offering:

	<p>Pressure Measurement</p>		<p>Level Measurement</p>
	<p>Temperature Measurement</p>		<p>Flow Measurement</p>
	<p>Marine Measurement & Analytical</p>		<p>Gas Analysis</p>
	<p>Liquid Analysis</p>		<p>Flame and Gas Detection</p>
	<p>Tank Gauging</p>		<p>Wireless Infrastructure</p>
	<p>Acoustic & Discrete</p>	 <p>HIGH ACCURACY</p> <p>measurement instruments</p>	

www.high-accuracy.com